

OJ5054

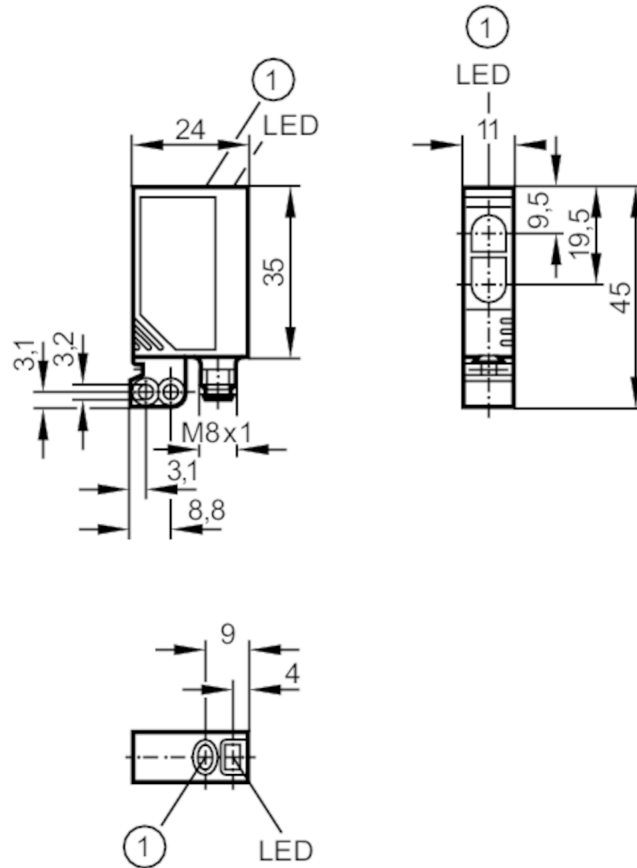

Laser diffuse reflection sensor

OJHLFPKG/SO/AS



- 1 pushbutton receiver in upper lens transmitter in lower lens



Application

Function principle Diffuse reflection sensor

Electrical data

Operating voltage [V]	10...30 DC
Current consumption [mA]	13
Protection class	III
Reverse polarity protection	yes
Type of light	red light
Wave length [nm]	650
Typ. lifetime [h]	50000

OJ5054



Laser diffuse reflection sensor

OJHLFPKG/SO/AS

Outputs		
Electrical design	PNP	
Output function	light-on/dark-on mode; (programmable)	
Max. voltage drop switching output DC [V]	2.5	
Permanent current rating of switching output DC [mA]	200	
Switching frequency DC [Hz]	1000	
Short-circuit protection	yes	
Type of short-circuit protection	pulsed	
Overload protection	yes	
Detection zone		
Range [mm]	15...200; (white paper 200 x 200 mm 90 % remission)	
Range on white object (90 % remission) [mm]	15...200	
Range on grey object (18 % remission) [mm]	15...70	
Range on black object (6 % remission) [mm]	15...45	
Range adjustable	yes	
Diameter of the smallest detectable object [mm]	2	
Max. light spot width [mm]	2	
Max. light spot height [mm]	1	
Background suppression available	yes	
Operating conditions		
Ambient temperature [°C]	-10...60	
Protection	IP 67	
Tests / approvals		
EMC	EN 60947-5-2	
Laser protection class	1; (IEC 60825-1 : 2007; Complies with 21 CFR 1040 except for deviations pursuant to Laser Notice No. 50, dated June 2007.)	
MTTF [years]	501	
Mechanical data		
Weight [g]	42.6	
Housing	rectangular	
Dimensions [mm]	35 x 11 x 24	
Materials	housing: ABS; fixture: diecast zinc; LED window: SEPS; pushbutton: SEPS	
Lens material	PMMA	
Lens alignment	side lens	
Displays / operating elements		
Display	switching status	1 x LED, yellow
	operation	1 x LED, green
Electronic lock	yes	

OJ5054



Laser diffuse reflection sensor

OJHLFPKG/SO/AS

Accessories	
Accessories (supplied)	Basic clip: 1 x, E20964
	screws: 2 x x M3 x 16
	spring washers: 2 x
	Nuts: 2 x

Remarks	
Remarks	operating voltage "supply class 2" according to cULus
Pack quantity	1 pcs.

Electrical connection

Connector: 1 x M8



Connection

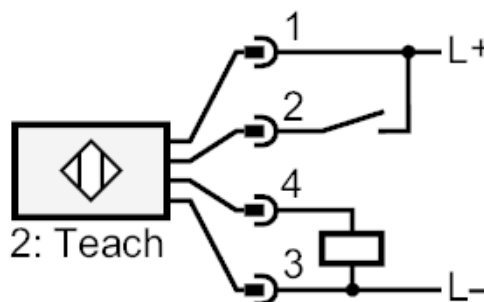

2 Teach



Laser diffuse reflection sensor

OJHLFPKG/SO/AS

Diagrams and graphs

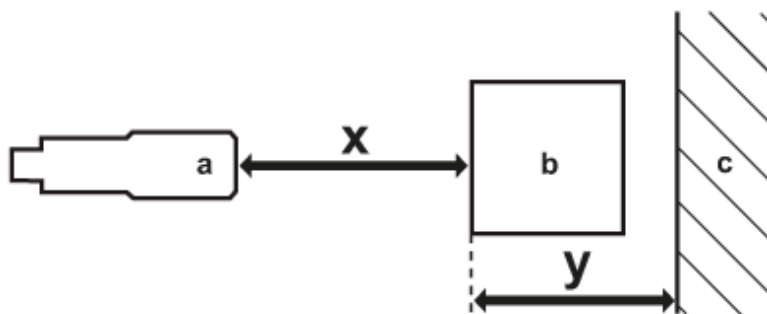

- a: sensor
- b: object
- c: background
- x: distance sensor/object [mm]
- y: min. distance object/background [mm]

accuracy graph

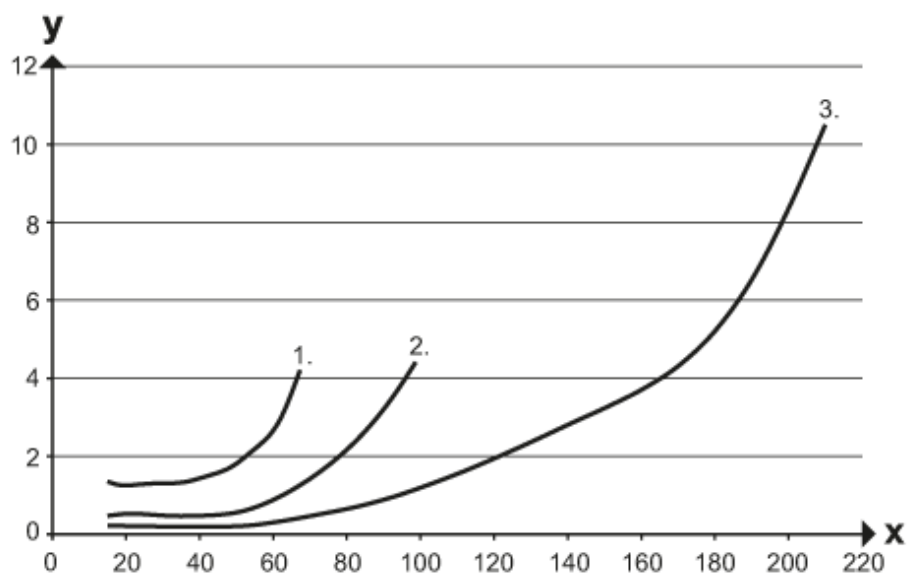

- x: distance sensor/object [mm]
- y: min. distance object/background [mm]
- 1 = object black (6 % remission) , background (white 90 % remission)
- 2 = object grey (18 % remission) , background (white 90 % remission)
- 3 = object white (90 % remission) , background (white 90 % remission)