



Main

| | |
|------------------------------|--|
| Range of product | Altivar 71Q |
| Product or component type | Variable speed drive |
| Device short name | ATV71Q |
| Product destination | Synchronous motors Asynchronous motors |
| Product specific application | Complex, high-power machines |
| Assembly style | With heat sink |
| Variant | Reinforced version |
| EMC filter | Integrated |
| Network number of phases | 3 phases |
| [Us] rated supply voltage | 380...480 V - 15...10 % |
| Supply voltage limits | 323...528 V |
| Supply frequency | 50...60 Hz - 5...5 % |
| Network frequency limits | 47.5...63 Hz |
| Motor power kW | 355 kW, 3 phases at 380...480 V 400 kW, 3 phases at 380...480 V |
| Motor power hp | 600 hp, 3 phases at 380...480 V |
| Maximum motor cable length | 100 m shielded cable without motor choke 200 m unshielded cable without motor choke 250 m shielded cable with motor choke 300 m unshielded cable with motor choke |
| Line current | 637 A for 380 V 3 phases 355 kW 709 A for 380 V 3 phases 400 kW / 600 hp 512 A for 480 V 3 phases 355 kW 568 A for 480 V 3 phases 400 kW / 600 hp |

Complementary

| | |
|----------------------------------|--|
| Apparent power | 419.3 kVA at 380 V 3 phases 355 kW 466.6 kVA at 380 V 3 phases 400 kW / 600 hp |
| Prospective line I _{sc} | 50 kA for 3 phases |
| Continuous output current | 671 A at 2.5 kHz, 380 V - 3 phases 759 A at 2.5 kHz, 380 V - 3 phases 671 A at 2.5 kHz, 460 V - 3 phases 759 A at 2.5 kHz, 460 V - 3 phases |
| Maximum transient current | 1107 A for 2 s, 3 phases |

1252 A for 2 s, 3 phases
 1006 A for 60 s, 3 phases
 1138 A for 60 s, 3 phases

| | |
|------------------------------------|---|
| Speed drive output frequency | 0.1...500 Hz |
| Nominal switching frequency | 2.5 kHz |
| Switching frequency | 2...8 kHz adjustable 2.5...8 kHz with derating factor |
| Speed range | 1...100 for asynchronous motor in open-loop mode, without speed feedback 1...50 for synchronous motor in open-loop mode, without speed feedback 1...1000 for asynchronous motor in closed-loop mode with encoder feedback |
| Speed accuracy | +/- 0.01 % of nominal speed in closed-loop mode with encoder feedback 0.2 Tn to Tn +/- 10 % of nominal slip without speed feedback 0.2 Tn to Tn |
| Torque accuracy | +/- 5 % in closed-loop mode with encoder feedback +/- 15 % in open-loop mode, without speed feedback |
| Transient overtorque | 170 % of nominal motor torque +/- 10 % for 60 s 220 % of nominal motor torque +/- 10 % for 2 s |
| Braking torque | 30 % without braking resistor <= 150 % with braking or hoist resistor |
| Asynchronous motor control profile | Flux vector control without sensor, 2 points Voltage/frequency ratio - Energy Saving, quadratic U/f Flux vector control with sensor, standard Flux vector control without sensor, ENA (energy Adaptation) system Voltage/frequency ratio, 2 points Flux vector control without sensor, standard Voltage/frequency ratio, 5 points |
| Synchronous motor control profile | Vector control with sensor, standard Vector control without sensor, standard |
| Regulation loop | Adjustable PI regulator |
| Motor slip compensation | Suppressable Adjustable Automatic whatever the load Not available in voltage/frequency ratio (2 or 5 points) |
| Local signalling | 1 LED (red)drive voltage: |
| Output voltage | <= power supply voltage |
| Isolation | Electrical between power and control |
| Type of cable | Without mounting kit: 1 wire(s)IEC cable at 45 °C, copper 90 °C / XLPE/EPR Without mounting kit: 1 wire(s)IEC cable at 45 °C, copper 70 °C / PVC With an IP21 or an IP31 kit: 3 wire(s)IEC cable at 40 °C, copper 70 °C / PVC With a NEMA Type1 kit: 3 wire(s)UL 508 cable at 40 °C, copper 75 °C / PVC |
| Electrical connection | Terminal 2.5 mm ² / AWG 14 (AI1-/AI1+, AI2, AO1, R1A, R1B, R1C, R2A, R2B, LI1...LI6, PWR) Terminal 8 x 185 mm ² (PC/-, PA/+) Terminal 2 x 2 x 185 mm ² (R/L1.1, S/L2.1, T/L3.1, R/L1.2, S/L2.2, T/L3.2) Terminal 4 x 185 mm ² (U/T1, V/T2, W/T3) |
| Tightening torque | 41 N.m, 360 lb.in (PC/-, PA/+) 41 N.m, 360 lb.in (R/L1.1, S/L2.1, T/L3.1, R/L1.2, S/L2.2, T/L3.2) 41 N.m, 360 lb.in (U/T1, V/T2, W/T3) 0.6 N.m (AI1-/AI1+, AI2, AO1, R1A, R1B, R1C, R2A, R2B, LI1...LI6, PWR) |
| Supply | Internal supply for reference potentiometer (1 to 10 kOhm): 10.5 V DC, +/- 5 %, <10 mA with overload and short-circuit protection Internal supply: 24 V DC (21...27 V), <200 mA with overload and short-circuit protection |
| Analogue input number | 2 |
| Analogue input type | AI2 software-configurable voltage: 0...10 V DC 24 V max, impedance: 30000 Ohm, resolution 11 bits AI1-/AI1+ bipolar differential voltage: +/- 10 V DC 24 V max, resolution 11 bits + sign AI2 software-configurable current: 0...20 mA, impedance: 242 Ohm, resolution 11 bits |
| Sampling duration | 2 ms +/- 0.5 ms (LI6)if configured as logic input - discrete input 2 ms +/- 0.5 ms (LI1...LI5) - discrete input 2 ms +/- 0.5 ms (AI1-/AI1+) - analog output 2 ms +/- 0.5 ms (AI2) - analog output |
| Accuracy | +/- 0.6 % (AI1-/AI1+) for a temperature variation 60 °C +/- 0.6 % (AI2) for a temperature variation 60 °C +/- 1 % (AO1) for a temperature variation 60 °C |
| Linearity error | +/- 0.15 % of maximum value (AI1-/AI1+, AI2) +/- 0.2 % (AO1) |
| Analogue output number | 1 |
| Analogue output type | AO1 software-configurable voltage: 0...10 V DC, impedance: 470 Ohm, resolution 10 bits |

AO1 software-configurable current: 0...20 mA, impedance: 500 Ohm, resolution 10 bits
 AO1 software-configurable logic output 10 V 20 mA

| | |
|-------------------------------------|---|
| Discrete output number | 2 |
| Discrete output type | Configurable relay logic: (R1A, R1B, R1C) NO/NC - 100000 cycles Configurable relay logic: (R2A, R2B) NO - 100000 cycles |
| Response time | R1A, R1B, R1C 7 ms, tolerance +/- 0.5 ms R2A, R2B 7 ms, tolerance +/- 0.5 ms AO1 2 ms, tolerance +/- 0.5 ms <= 100 ms in STO (Safe Torque Off) |
| Minimum switching current | 3 mA at 24 V DC for configurable relay logic |
| Maximum switching current | 5 A at 250 V AC on resistive load - cos phi = 1 - L/R = 0 ms (R1, R2) 5 A at 30 V DC on resistive load - cos phi = 1 - L/R = 0 ms (R1, R2) 2 A at 250 V AC on inductive load - cos phi = 0.4 - L/R = 7 ms (R1, R2) 2 A at 30 V DC on inductive load - cos phi = 0.4 - L/R = 7 ms (R1, R2) |
| Discrete input number | 7 |
| Discrete input type | LI1...LI5: programmable 24 V DC with level 1 PLC, impedance: 3500 Ohm LI6: switch-configurable 24 V DC with level 1 PLC, impedance: 3500 Ohm LI6: switch-configurable PTC probe 0...6, impedance: 1500 Ohm PWR: safety input 24 V DC, impedance: 1500 Ohm conforming to ISO 13849-1 level d |
| Discrete input logic | Positive logic (source) (LI6)if configured as logic input, < 5 V (state 0), > 11 V (state 1) Negative logic (sink) (LI6)if configured as logic input, > 16 V (state 0), < 10 V (state 1) Positive logic (source) (LI1...LI5), < 5 V (state 0), > 11 V (state 1) Negative logic (sink) (LI1...LI5), > 16 V (state 0), < 10 V (state 1) Positive logic (source) (PWR), < 2 V (state 0), > 17 V (state 1) |
| Acceleration and deceleration ramps | Linear adjustable separately from 0.01 to 9000 s Automatic adaptation of ramp if braking capacity exceeded, by using resistor S, U or customized |
| Braking to standstill | By DC injection |
| Protection type | Overheating protection: drive Thermal protection: drive Short-circuit between motor phases: drive Input phase breaks: drive Overcurrent between output phases and earth: drive Overvoltages on the DC bus: drive Break on the control circuit: drive Against exceeding limit speed: drive Line supply undervoltage: drive Line supply overvoltage: drive Against input phase loss: drive Thermal protection: motor Motor phase break: motor Power removal: motor |
| Dielectric strength | 3535 V DC between earth and power terminals 5092 V DC between control and power terminals |
| Insulation resistance | > 1 mOhm 500 V DC for 1 minute to earth |
| Frequency resolution | Display unit: 0.1 Hz Analog input: 0.024/50 Hz |
| Communication port protocol | CANopen Modbus |
| Connector type | 1 RJ45 (on front face) for Modbus 1 RJ45 (on terminal) for Modbus 1 RJ45 for CANopen |
| Physical interface | 2-wire RS 485 for Modbus |
| Transmission frame | RTU for Modbus |
| Transmission rate | 9600 bps, 19200 bps for Modbus on front face 4800 bps, 9600 bps, 19200 bps, 38.4 Kbps for Modbus on terminal 20 kbps, 50 kbps, 125 kbps, 250 kbps, 500 kbps, 1 Mbps for CANopen |
| Data format | 8 bits, 1 stop, even parity for Modbus on front face 8 bits, odd even or no configurable parity for Modbus on terminal |
| Type of polarization | No impedance for Modbus |
| Number of addresses | 1...247 for Modbus 1...127 for CANopen |
| Method of access | Slave CANopen |
| Type of cooling | Water cooled |
| Cooling fluid type | Clean water |

| | |
|-----------------------------|---|
| | Industrial water Water-glycol mixture |
| Operating temperature water | 5...55 °C |
| Thermal losses | 6700 W 100 % of line current for area of liquid cooling (power part) 1600 W 100 % of line current for area of air cooling (control part) |
| Flow velocity | 24 |
| Maximum pressure drop | 2 bar |
| Volume of cooling water | 0.7 l |
| Operating position | Vertical +/- 10 degree |
| Product weight | 300 kg |
| Option card | Communication card for Modbus TCP Communication card for Fipio Communication card for Modbus/Uni-Telway Communication card for Modbus Plus Communication card for Ethernet/IP Communication card for DeviceNet Communication card for Profibus DP Communication card for Profibus DP V1 Communication card for Interbus-S Communication card for CC-Link Interface card for encoder I/O extension card Controller inside programmable card Overhead crane card |
| Width | 1110 mm |
| Height | 1150 mm |
| Depth | 377 mm |

Environment

| | |
|---------------------------------------|---|
| Ambient air temperature for operation | -10...50 °C (without) |
| Ambient air temperature for storage | -25...70 °C |
| Operating altitude | <= 1000 m without 1000...3000 m with current derating 1 % per 100 m |
| Electromagnetic compatibility | Electrostatic discharge immunity test level 3 conforming to IEC 61000-4-2 Radiated radio-frequency electromagnetic field immunity test level 3 conforming to IEC 61000-4-3 Electrical fast transient/burst immunity test level 4 conforming to IEC 61000-4-4 1.2/50 µs - 8/20 µs surge immunity test level 3 conforming to IEC 61000-4-5 Conducted radio-frequency immunity test level 3 conforming to IEC 61000-4-6 Voltage dips and interruptions immunity test conforming to IEC 61000-4-11 |
| Pollution degree | 2 conforming to EN/IEC 61800-5-1 3 conforming to UL 840 |
| IP degree of protection | IP00 conforming to EN/IEC 61800-5-1 IP00 conforming to EN/IEC 60529 IP41 on upper part conforming to EN/IEC 61800-5-1 IP41 on upper part conforming to EN/IEC 60529 IP30 on the front panel conforming to EN/IEC 61800-5-1 IP30 on the front panel conforming to EN/IEC 60529 IP30 on side parts conforming to EN/IEC 61800-5-1 IP30 on side parts conforming to EN/IEC 60529 IP54 on lower part conforming to EN/IEC 61800-5-1 IP54 on lower part conforming to EN/IEC 60529 |
| Vibration resistance | 1.5 mm peak to peak (f= 3...10 Hz) conforming to EN/IEC 60068-2-6 0.6 gn (f= 10...200 Hz) conforming to EN/IEC 60068-2-6 |
| Shock resistance | 4 gn for 11 ms conforming to EN/IEC 60068-2-27 |
| Relative humidity | 5...95 % without condensation conforming to IEC 60068-2-3 5...95 % without dripping water conforming to IEC 60068-2-3 |
| Noise level | 77 dB conforming to 86/188/EEC |
| Standards | EN/IEC 61800-3 IEC 61508 SIL2 EN/IEC 61800-5-1 EN 61800-3 environments 1 category C3 UL Type 1 EN 55011 class A group 2 EN 61800-3 environments 2 category C3 ISO 13849-1 level d |

| | |
|------------------------|--|
| Product certifications | GOST NOM 117 C-Tick CSA UL |
| Marking | CE |

Offer Sustainability

| | |
|----------------------------|---|
| REACH Regulation | REACH Declaration |
| EU RoHS Directive | Pro-active compliance (Product out of EU RoHS legal scope) EU RoHS Declaration |
| Mercury free | Yes |
| RoHS exemption information | Yes |
| China RoHS Regulation | China RoHS declaration |
| WEEE | The product must be disposed on European Union markets following specific waste collection and never end up in rubbish bins |

Contractual warranty

| | |
|----------|-----------|
| Warranty | 18 months |
|----------|-----------|

Dimensions

Without or with 1 option card

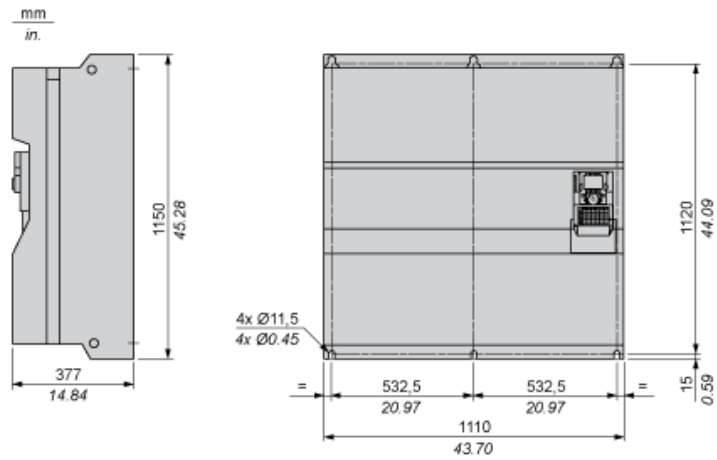

With 2 option cards

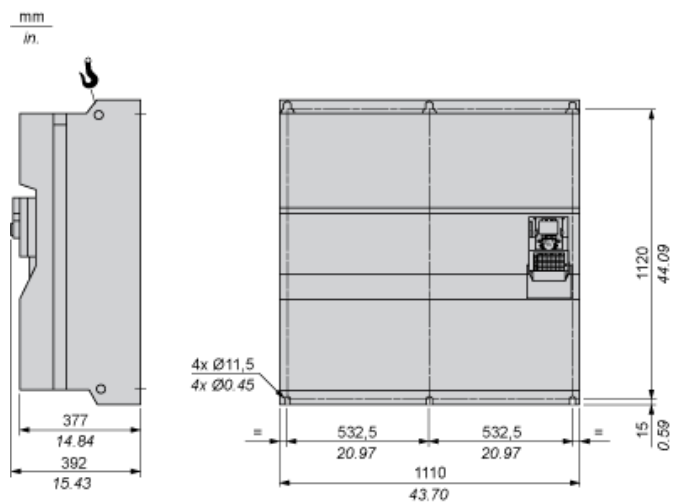

Clearance

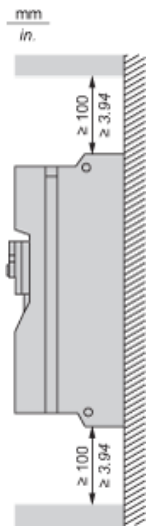

Wall-Mounting

The drive is designed for installation on the wall, in an electrical room or into an enclosure. The device is built according to pollution degree 2. If the environment does not correspond to these conditions then the necessary transition of the pollution degree must be provided e.g. by means of an enclosure.

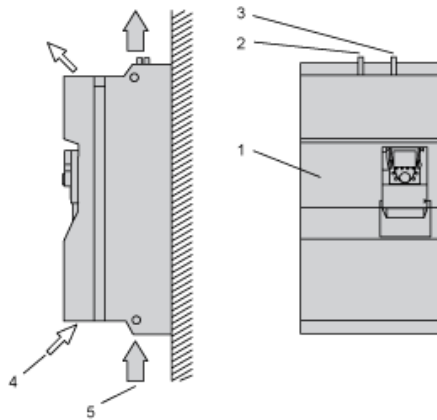

- (1) Drive
- (2) Cooling water inlet
- (3) Cooling water return
- (4) Cooling air for control part
- (5) Cooling air for power part (only capacitors)

Wiring Diagram

Standard 6-pulse Design

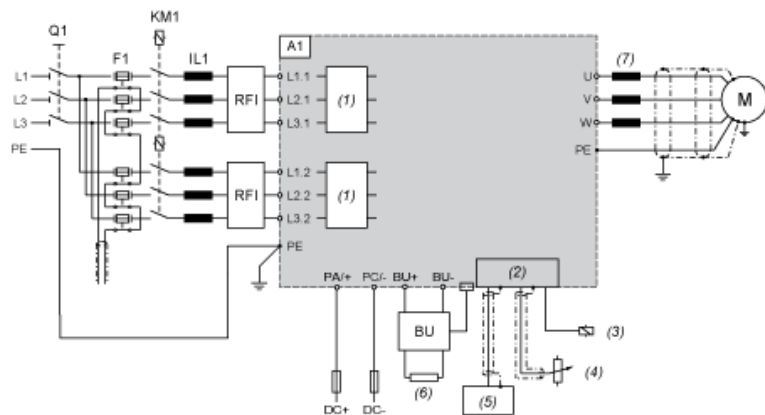

- A1 Drive
- BU Braking Unit
- F1 Fast-acting semi-conductor fuse
- IL1 Line choke
- KM1 Optional line contactor
- M Motor
- Q1 Switch
- RFI Optional radio frequency interference filter
- (1) Filter
- (2) Control
- (3) Relay control
- (4) Control potentiometer
- (5) PLC
- (6) External optional braking resistor
- (7) Optional motor choke

Optional 12-pulse Design

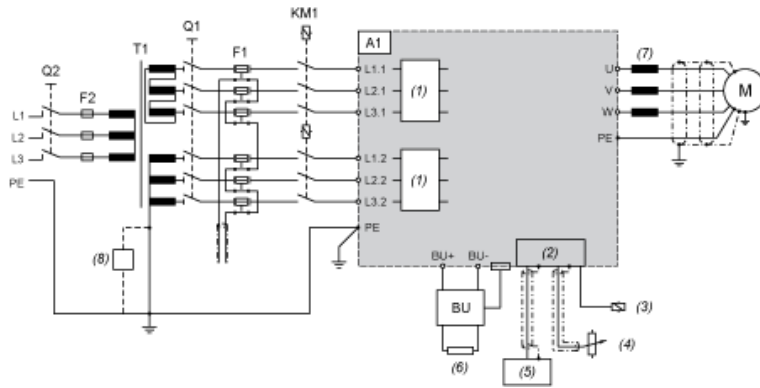

- A1 Drive
- BU Braking Unit
- F1, F2 Fast-acting semi-conductor fuse
- KM1 Optional line contactor
- M Motor
- Q1, Q2 Switches
- T1 Transformer with two out-of-phase secondary windings
- (1) Filter
- (2) Control
- (3) Relay control
- (4) Control potentiometer
- (5) PLC
- (6) External optional braking resistor
- (7) Optional motor choke
- (8) Insulation monitoring relay

Continuous Current at Output Frequencies < 1 Hz

Due to the especially efficient liquid cooling of the drive the full overload capability is also available in the speed range of 0 Hz.

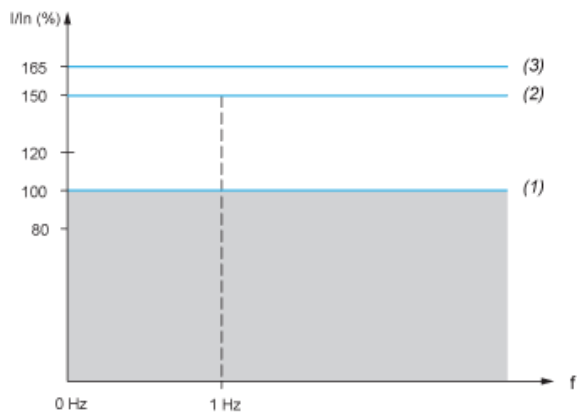

- (1) Continuous operation: 150% (165%) overload capability
- (2) Overload 150% for 60 s
- (3) Overload 165% for 2 s

Power Derating

| | |
|-----------------------|----------------------|
| 4 kHz pulse frequency | +5°K air temperature |
| 8% | 10% |