



### Main

Range of product	Altivar Machine ATV340
Product or component type	Variable speed drive
Device application	Machine
Device short name	ATV340
Variant	Standard version
Product destination	Synchronous motors Asynchronous motors
Mounting mode	Cabinet mount
EMC filter	Integrated with 20 m conforming to EN/IEC 61800-3 category C3
IP degree of protection	IP20 conforming to IEC 61800-5-1 IP20 conforming to IEC 60529
Type of cooling	Forced convection
Supply frequency	50...60 Hz +/- 5 %
Network number of phases	3 phases
[Us] rated supply voltage	380...480 V - 15...10 %
Motor power kW	11 kW for normal duty 7.5 kW for heavy duty
Motor power hp	15 hp for normal duty 10 hp for heavy duty
Line current	25.6 A at 380 V without line choke (heavy duty) 20.4 A at 480 V without line choke (heavy duty) 22 A at 380 V with external line choke (normal duty) 17.7 A at 480 V with external line choke (normal duty) 14.6 A at 380 V with external line choke (heavy duty) 12.1 A at 480 V with external line choke (heavy duty)
Prospective line I <sub>sc</sub>	22 kA
Apparent power	17 kVA at 480 V (normal duty) 17 kVA at 480 V (heavy duty)
Continuous output current	24 A at 4 kHz for normal duty 16.5 A at 4 kHz for heavy duty
Maximum transient current	26.4 A during 60 s (normal duty)

Disclaimer: This documentation is not intended as a substitute for and is not to be used for determining suitability or reliability of these products for specific user applications

	24.8 A during 60 s (heavy duty) 32.4 A during 2 s (normal duty) 29.7 A during 2 s (heavy duty)
Asynchronous motor control profile	Variable torque standard Constant torque standard Optimized torque mode
Synchronous motor control profile	Permanent magnet motor Reluctance motor
Speed drive output frequency	0.1...599 Hz
Nominal switching frequency	4 kHz
Switching frequency	2...16 kHz adjustable 4...16 kHz with derating factor
Safety function	STO (safe torque off) SIL 3

## Complementary

Number of preset speeds	16 preset speeds
Communication port protocol	Modbus serial
Option card	Slot GP-FB: communication module for Profibus DP V1 Slot GP-FB: communication module for Profinet Slot GP-FB: communication module for DeviceNet Slot GP-FB: communication module for CANopen daisy chain RJ45 Slot GP-FB: communication module for CANopen SUB-D 9 Slot GP-FB: communication module for CANopen screw terminals Slot GP-FB: communication module for EtherCAT Slot GP-X: digital and analog I/O extension module Slot GP-X: output relay extension module Slot GP-ENC: 5/12 V digital encoder interface module Slot GP-ENC: analog encoder interface module Slot GP-ENC: resolver encoder interface module
Output voltage	<= power supply voltage
Permissible temporary current boost	1.1 x I <sub>n</sub> during 60 s (normal duty) 1.35 x I <sub>n</sub> during 2 s (normal duty) 1.5 x I <sub>n</sub> during 60 s (heavy duty) 1.8 x I <sub>n</sub> during 2 s (heavy duty)
Motor slip compensation	Automatic whatever the load Can be suppressed Adjustable Not available in permanent magnet motor law
Acceleration and deceleration ramps	Linear adjustable separately from 0.01...9999 s S, U or customized
Braking to standstill	By DC injection
Protection type	Thermal protection: motor Safe torque off: motor Motor phase loss: motor Thermal protection: drive Safe torque off: drive Overheating: drive Overcurrent: drive Output overcurrent between motor phase and earth: drive Output overcurrent between motor phases: drive Short-circuit between motor phase and earth: drive Short-circuit between motor phases: drive Motor phase loss: drive DC Bus overvoltage: drive Line supply overvoltage: drive Line supply undervoltage: drive Input supply loss: drive Exceeding limit speed: drive Break on the control circuit: drive
Frequency resolution	Display unit: 0.1 Hz Analog input: 0.012/50 Hz
Electrical connection	DC bus: screw terminal 4...6 mm <sup>2</sup> /AWG 12...AWG 10 Control: screw terminal 0.2...2.5 mm <sup>2</sup> /AWG 24...AWG 12 Motor: screw terminal 1.5...6 mm <sup>2</sup> /AWG 14...AWG 10 Line side: screw terminal 2.5...6 mm <sup>2</sup> /AWG 12...AWG 10
Connector type	connector(s) 1 x RJ45, Modbus serial on front face connector(s) 1 x RJ45, Modbus serial for HMI on front face

Physical interface	2-wire RS 485 for Modbus serial
Transmission frame	RTU for Modbus serial
Transmission rate	4800 bps, 9600 bps, 19200 bps, 38.4 Kbps for Modbus serial
Data format	8 bits, configurable odd, even or no parity for Modbus serial
Type of polarization	No impedance for Modbus serial
Number of addresses	1...247 for Modbus serial
Method of access	Slave Modbus RTU
Supply	External supply for digital inputs: 24 V DC (19...30 V), <1.25 mA, protection type: overload and short-circuit protection Internal supply for reference potentiometer (1 to 10 kOhm): 10.5 V DC +/- 5 %, <10 mA, protection type: overload and short-circuit protection Internal supply for digital inputs and STO: 24 V DC (21...27 V), <200 mA, protection type: overload and short-circuit protection
Local signalling	Local diagnostic: 4 LED (mono/dual colour) Communication module status: 4 LED (dual colour)
Width	110 mm
Height	270 mm
Depth	234 mm
Product weight	3 kg
Analogue input number	2
Analogue input type	AI1 software-configurable current: 0...20 mA, impedance: 250 Ohm, resolution 12 bits AI1 software-configurable temperature probe or water level sensor AI1 software-configurable voltage: 0...10 V DC, impedance: 31.5 kOhm, resolution 12 bits AI2 software-configurable voltage: - 10...10 V DC, impedance: 20 kOhm, resolution 12 bits
Discrete input number	8
Discrete input type	PTI programmable as pulse input: 0...30 kHz, 24 V DC (<= 30 V) STOA, STOB safe torque off, 24 V DC (<= 30 V), impedance: > 2.2 kOhm DI1...DI5 programmable, 24 V DC (<= 30 V), impedance: 4.4 kOhm
Input compatibility	DI1...DI5: discrete input level 1 PLC conforming to EN/IEC 61131-2 PTI: pulse input level 1 PLC conforming to IEC 65A-68 STOA, STOB: discrete input level 1 PLC conforming to EN/IEC 61131-2
Discrete input logic	Positive logic (source) (DI1...DI5), < 5 V (state 0), > 11 V (state 1) Negative logic (sink) (DI1...DI5), > 16 V (state 0), < 10 V (state 1) Positive logic (source) (PTI), < 0.6 V (state 0), > 2.5 V (state 1) Positive logic (source) (STOA, STOB), < 5 V (state 0), > 11 V (state 1)
Analogue output number	1
Analogue output type	Software-configurable voltage AQ1: 0...10 V DC impedance 470 Ohm, resolution 10 bits Software-configurable current AQ1: 0...20 mA impedance 500 Ohm, resolution 10 bits
Input/Output type	Programmable as logic input/output DQ1: 0...1 kHz, <= 30 V DC, 100 mA Programmable as logic input/output DQ2: 0...1 kHz, <= 30 V DC, 100 mA
Sampling duration	2 ms +/- 0.5 ms (DI1...DI5) - discrete input 5 ms +/- 1 ms (PTI) - pulse input 1 ms +/- 1 ms (AI1, AI2) - analog input 5 ms +/- 1 ms (AQ1) - analog output 2 ms +/- 0.5 ms (DQ1, DQ2) - discrete input/output
Accuracy	+/- 0.6 % AI1, AI2 for a temperature variation 60 °C analog input +/- 1 % AQ1 for a temperature variation 60 °C analog output
Linearity error	AI1, AI2: +/- 0.15 % of maximum value for analog input AQ1: +/- 0.2 % for analog output
Relay output number	2
Relay output type	Configurable relay logic R1: fault relay NO/NC electrical durability 100000 cycles Configurable relay logic R2: sequence relay NO electrical durability 100000 cycles
Refresh time	Relay output (R1, R2): 5 ms (+/- 0.5 ms)
Minimum switching current	Relay output R1, R2: 5 mA at 24 V DC
Maximum switching current	Relay output R1 on resistive load, cos phi = 1: 3 A at 250 V AC Relay output R1 on resistive load, cos phi = 1: 3 A at 30 V DC Relay output R1 on inductive load, cos phi = 0.4 and L/R = 7 ms: 2 A at 250 V AC Relay output R1 on inductive load, cos phi = 0.4 and L/R = 7 ms: 2 A at 30 V DC Relay output R2 on resistive load, cos phi = 1: 5 A at 250 V AC Relay output R2 on resistive load, cos phi = 1: 5 A at 30 V DC Relay output R2 on inductive load, cos phi = 0.4 and L/R = 7 ms: 2 A at 250 V AC Relay output R2 on inductive load, cos phi = 0.4 and L/R = 7 ms: 2 A at 30 V DC

## Environment

Isolation	Between power and control terminals
Insulation resistance	> 1 MOhm 500 V DC for 1 minute to earth
Noise level	46.5 dB conforming to 86/188/EEC
Power dissipation in W	Natural convection: 180 W at 380 V, switching frequency 4 kHz (heavy duty) Forced convection: 180 W at 380 V, switching frequency 4 kHz (heavy duty) Natural convection: 249 W at 380 V, switching frequency 4 kHz (normal duty) Forced convection: 249 W at 380 V, switching frequency 4 kHz (normal duty)
Operating position	Vertical +/- 10 degree
Electromagnetic compatibility	Electrostatic discharge immunity test level 3 conforming to IEC 61000-4-2 Radiated radio-frequency electromagnetic field immunity test level 3 conforming to IEC 61000-4-3 Electrical fast transient/burst immunity test level 4 conforming to IEC 61000-4-4 1.2/50 µs - 8/20 µs surge immunity test level 3 conforming to IEC 61000-4-5 Conducted radio-frequency immunity test level 3 conforming to IEC 61000-4-6
Pollution degree	2 conforming to EN/IEC 61800-5-1
Vibration resistance	1.5 mm peak to peak (f= 2...19 Hz) conforming to EN/IEC 60721-3-3 class 3M3 1 gn (f= 9...200 Hz) conforming to EN/IEC 60721-3-3 class 3M3
Shock resistance	15 gn for 11 ms, class 3M3 conforming to EN/IEC 60721-3-3
Relative humidity	5...95 % without condensation conforming to EN/IEC 60721-3-3 class 3K3
Ambient air temperature for operation	-15...50 °C without current derating (heavy duty) -15...40 °C without current derating (normal duty) 50...60 °C with current derating (heavy duty) 40...60 °C with current derating (normal duty)
Ambient air temperature for storage	-40...70 °C
Operating altitude	<= 1000 m without 1000...3000 m with current derating 1 % per 100 m
Environmental characteristic	Chemical pollution resistance class 3C3 conforming to EN/IEC 60721-3-3 Dust pollution resistance class 3S3 conforming to EN/IEC 60721-3-3
Standards	EN/IEC 61800-3 Environment 1 category C2 EN/IEC 61800-3 Environment 2 category C3 EN/IEC 61800-3 EN/IEC 61800-5-1 IEC 60721-3 IEC 61508 IEC 13849-1 UL 618000-5-1
Product certifications	TÜV CSA REACH UL
Marking	CE

## Offer Sustainability

Sustainable offer status	Green Premium product
REACH Regulation	<a href="#">REACH Declaration</a>
EU RoHS Directive	Pro-active compliance (Product out of EU RoHS legal scope) <a href="#">EU RoHS Declaration</a>
Mercury free	Yes
RoHS exemption information	<a href="#">Yes</a>
China RoHS Regulation	<a href="#">China RoHS declaration</a>
Environmental Disclosure	<a href="#">Product Environmental Profile</a>
Circularity Profile	<a href="#">End of Life Information</a>
WEEE	The product must be disposed on European Union markets following specific waste collection and never end up in rubbish bins

## Contractual warranty

Warranty	18 months
----------	-----------

## Dimensions

### Views: Front - Left - Rear

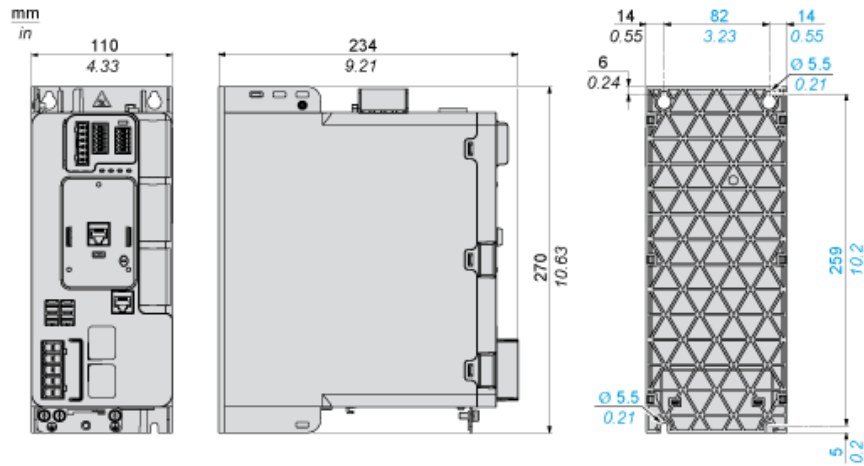

Clearance

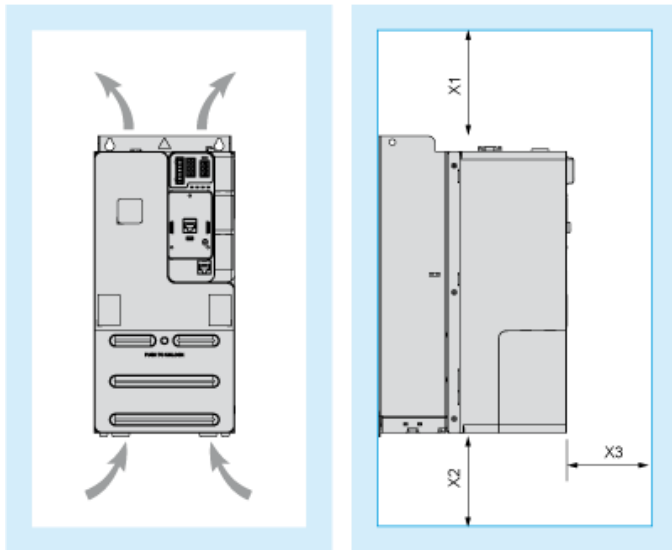

Dimensions in mm

X1	X2	X3
≥ 100	≥ 100	≥ 60

Dimensions in in.

X1	X2	X3
≥ 3.94	≥ 3.94	≥ 2.36

---

Mounting Types

---

Mounting Type A: Side by Side IP20

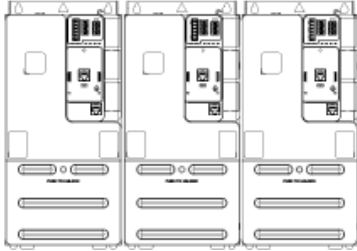

Possible, at ambient temperature  $\leq 50\text{ }^{\circ}\text{C}$  (122  $^{\circ}\text{F}$ )

Mounting Type B: Individual IP20

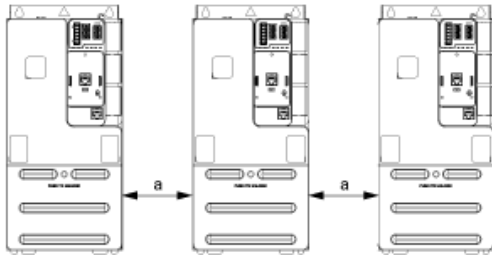

$a \geq 50\text{ mm}$  (1.97 in.) from 50...60 $^{\circ}\text{C}$ , no restriction below 50 $^{\circ}\text{C}$

Connections and Schema

Three-phase Power Supply with Upstream Breaking via Line Contactor Without Safety Function STO

Connection diagrams conforming to standards ISO13849 category 1 and IEC/EN 61508 capacity SIL1, stopping category 0 in accordance with standard IEC/EN 60204-1.

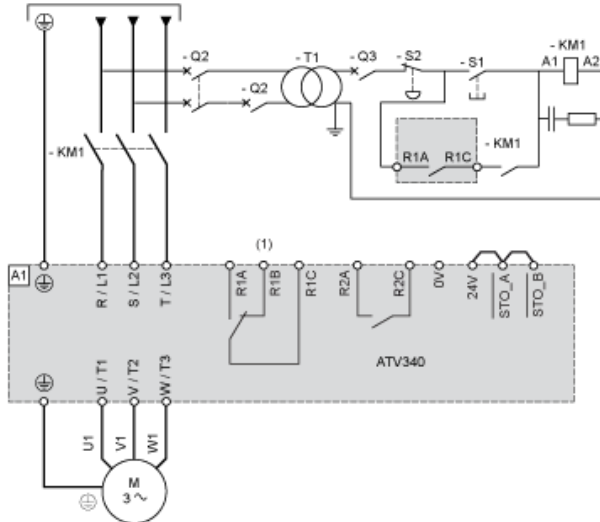

- (1) Use relay output R1 set to operating state Fault to switch Off the product once an error is detected.
- A1 : Drive
- KM1 : Line Contactor
- Q2, Q3 : Circuit breakers
- S1 : Pushbutton
- S2 : Emergency stop
- T1 : Transformer for control part

Three-phase Power Supply With Downstream Breaking via Switch Disconnecter

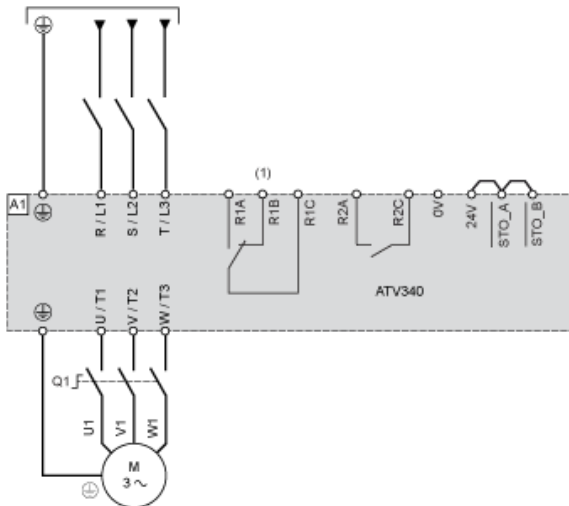

- (1) Use relay output R1 set to operating state Fault to switch Off the product once an error is detected.
- A1 : Drive
- Q1 : Switch disconnecter

## Sensor Connection

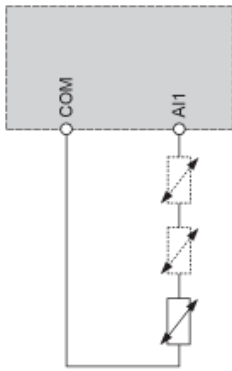

It is possible to connect either 1 or 3 sensors on terminals AI1.

## Control Block Wiring Diagram

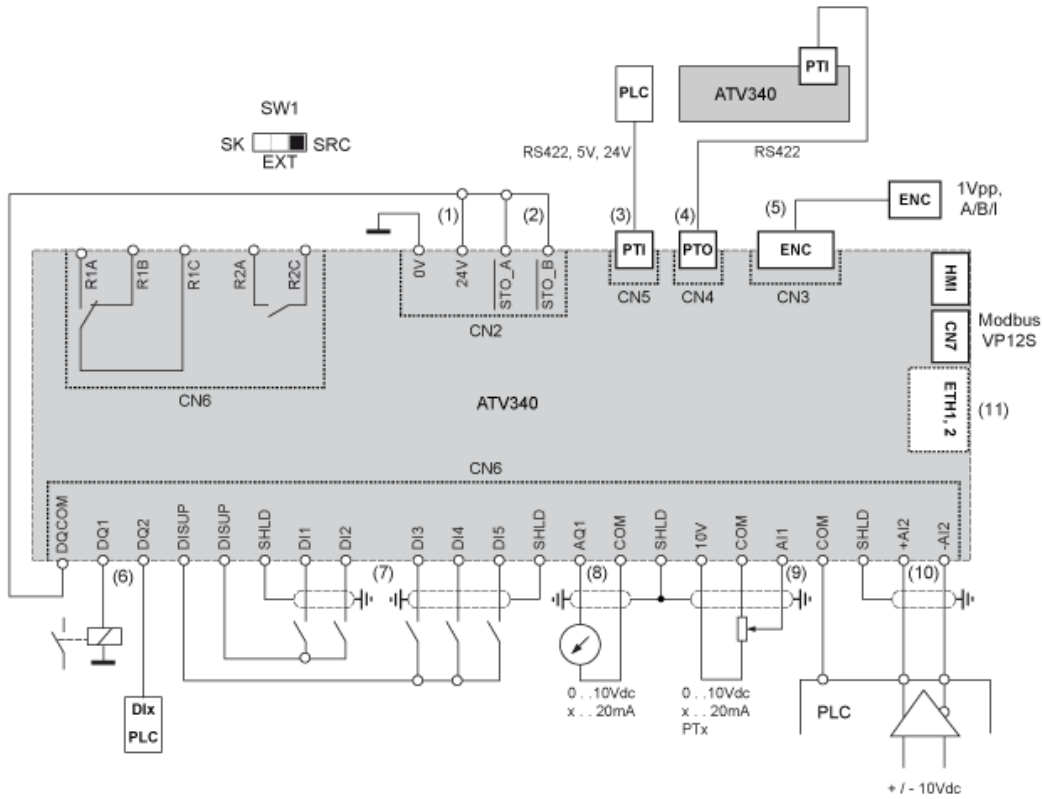

- (1) 24V supply (STO)
  - (2) STO - Safe Torque Off
  - (3) PTI - Pulse Train In
  - (4) PTO - Pulse Train Out
  - (5) Motor Encoder connection
  - (6) Digital outputs
  - (7) Digital inputs
  - (8) Analog output
  - (9) Analog input
  - (10) Differential Analog Input
  - (11) Ethernet port (only on Ethernet drive version)
- SW1 : Sink/Source switch  
 R1A, R1B, R1C Relay  
 R2A, R2C Sequence relay

## Digital Inputs Wiring

### Digital Inputs: Internal Supply

Using DISUP Signal

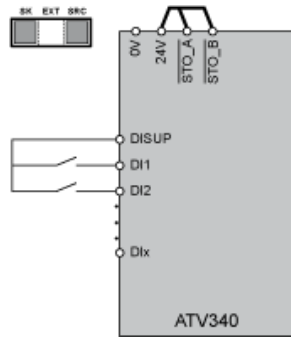

In SRC position DISUP outputs 24 V. In SK position DISUP is connected to 0 V.

### Digital Inputs: External Supply

Positive Logic, Source, European Style

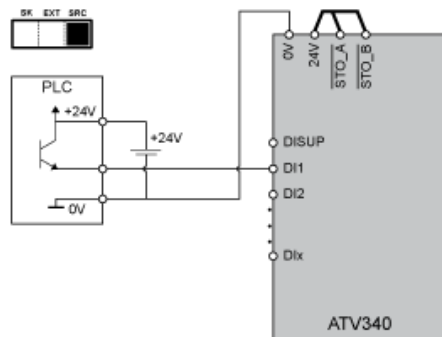

Negative Logic, Sink, Asian Style

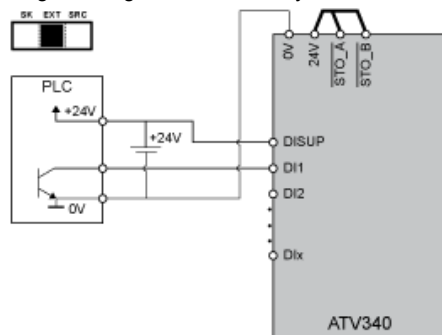

# Digital Inputs: Internal supply

Negative Logic, Sink, Asian Style

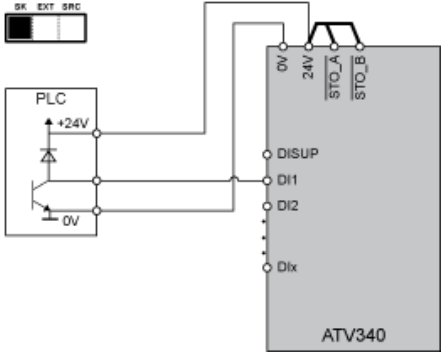

## Digital Outputs Wiring

### Digital Outputs: Internal Supply

Positive Logic, Source, European Style, DQCOM to +24V

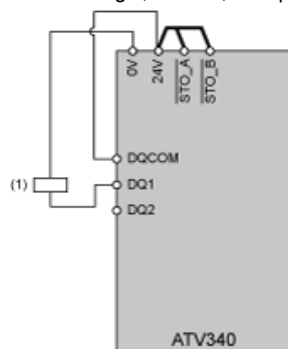

(1) Relay or valve

Negative Logic, Sink, Asian Style, DQCOM to 0V

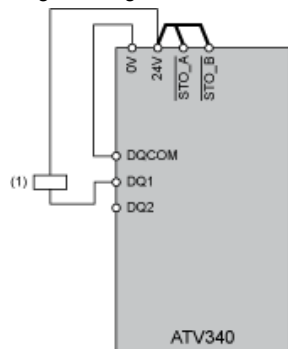

(1) Relay or valve

### Digital Outputs: External Supply

Positive Logic, Source, European Style, DQCOM to +24V

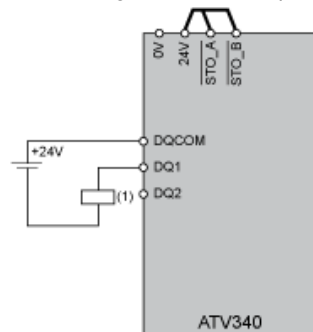

(1) Relay or valve

Negative Logic, Sink, Asian Style, DQCOM to 0V

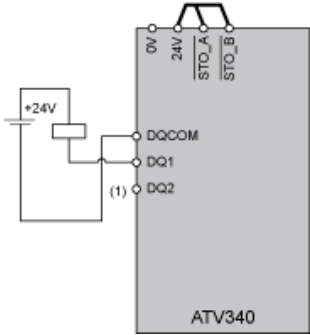

(1) Relay or valve

Open Loop Applications

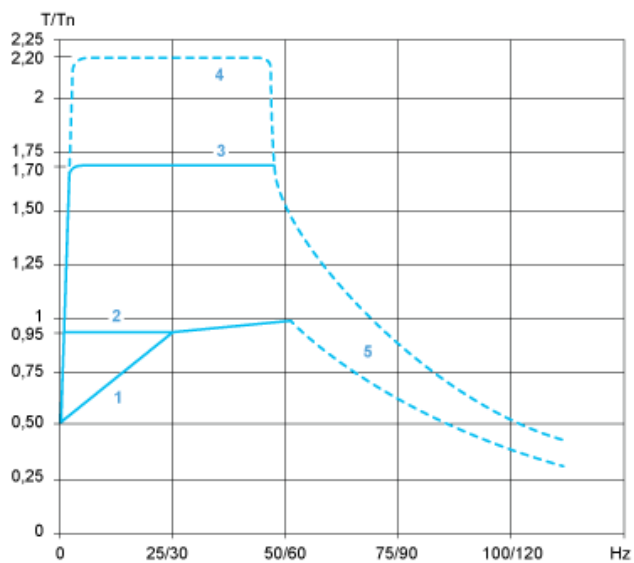

- 1 : Self-cooled motor: continuous useful torque
- 2 : Force-cooled motor: continuous useful torque
- 3 : Overtorque for 60 s maximum
- 4 : Transient overtorque for 2 s maximum
- 5 : Torque in overspeed at constant power

Closed Loop Applications

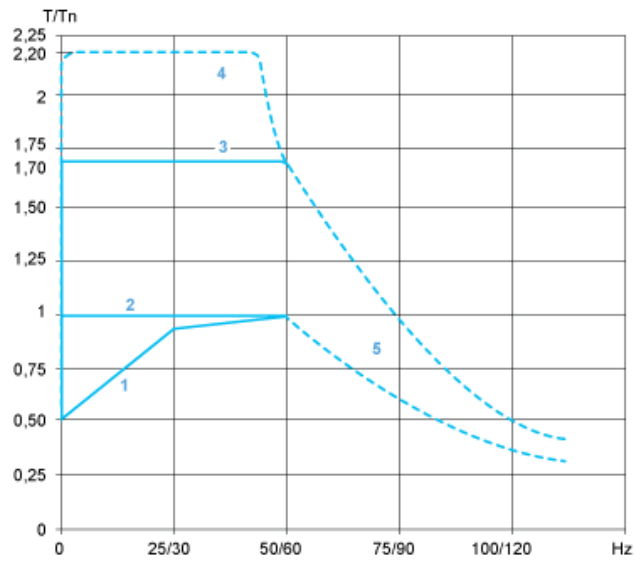

- 1 : Self-cooled motor: continuous useful torque
- 2 : Force-cooled motor: continuous useful torque
- 3 : Overtorque for 60 s maximum
- 4 : Transient overtorque for 2 s maximum
- 5 : Torque in overspeed at constant power