



Main

Range compatibility	Lexium 23 Plus
Product or component type	Servo motor
Device short name	BCH

Complementary

Maximum mechanical speed	5000 rpm
[Us] rated supply voltage	220 V
Network number of phases	Single phase
Continuous stall current	0.9 A
Continuous power	0.1 kW
Shaft end	Keyed
Second shaft	Without second shaft end
Shaft diameter	8 mm
Shaft length	20 mm
Key width	3 mm
Feedback type	20 bits incremental encoder
Holding brake	Without
Mounting support	Asian standard flange
Motor flange size	40 mm
Torque constant	0.36 N.m/A
Back emf constant	13.6 V/krpm at 20 °C
Rotor inertia	0.037 kg.cm ²
Stator resistance	18.6 Ohm at 20 °C
Stator inductance	48 mH at 20 °C
Stator electrical time constant	2.58 ms at 20 °C
Maximum radial force Fr	78.4 N
Maximum axial force Fa	39.2 N
Brake pull-in power	7.3 W
Type of cooling	Natural convection
Length	100.6 mm
Number of motor stacks	1

Disclaimer: This documentation is not intended as a substitute for and is not to be used for determining suitability or reliability of these products for specific user applications

Centring collar diameter	30 mm
Centring collar depth	2.5 mm
Number of mounting holes	4
Mounting holes diameter	4.5 mm
Circle diameter of the mounting holes	46 mm
Distance shaft shoulder-flange	20 mm
Product weight	0.5 kg

Environment

IP degree of protection	IP40
Ambient air temperature for operation	0...40 °C

Contractual warranty

Warranty	18 months
----------	-----------

Dimensions

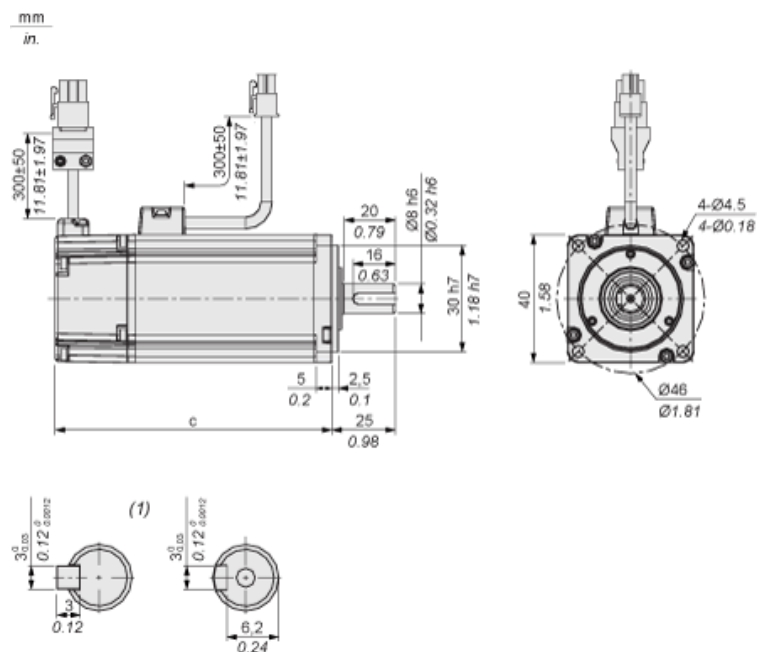

(1) Shaft end, keyed slot (optional)

Dimensions in mm

c (without holding brake)	c (with holding brake)
100.6	136.6

Dimensions in in.

c (without holding brake)	c (with holding brake)
3.96	5.38

Torque/Speed Curves with 220 V Single Phase Supply Voltage

Servo Motor with LXM23-U01M3X Servo Drive

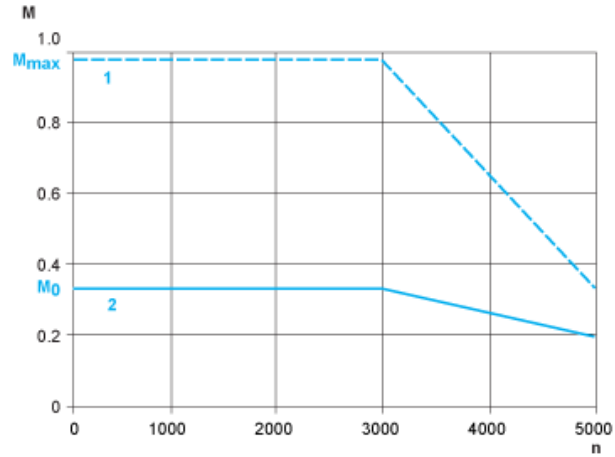

- M : Torque in Nm
- n : Speed in rpm
- 1 : Peak torque
- 2 : Continuous torque