



Main

| | |
|---------------------------|----------------|
| Range compatibility | Lexium 23 Plus |
| Product or component type | Servo motor |
| Device short name | BCH |

Complementary

| | |
|---------------------------------|-----------------------------|
| Maximum mechanical speed | 3000 rpm |
| [Us] rated supply voltage | 220 V |
| Network number of phases | Three phase |
| Continuous stall current | 19.4 A |
| Continuous power | 3 kW |
| Shaft end | Keyed |
| Second shaft | Without second shaft end |
| Shaft length | 73 mm |
| Key width | 10 mm |
| Feedback type | 20 bits incremental encoder |
| Holding brake | With |
| Holding torque | 25 N.m |
| Mounting support | Asian standard flange |
| Motor flange size | 180 mm |
| Torque constant | 0.98 N.m/A |
| Back emf constant | 35 V/krpm at 20 °C |
| Rotor inertia | 57.06 kg.cm ² |
| Stator resistance | 0.154 Ohm at 20 °C |
| Stator inductance | 2.54 mH at 20 °C |
| Stator electrical time constant | 16.5 ms at 20 °C |
| Maximum radial force Fr | 1470 N |
| Maximum axial force Fa | 490 N |
| Brake pull-in power | 20.4 W |
| Type of cooling | Natural convection |
| Length | 235.3 mm |
| Number of motor stacks | 2 |

| | |
|---------------------------------------|----------|
| Centring collar diameter | 114.3 mm |
| Centring collar depth | 4 mm |
| Number of mounting holes | 4 |
| Mounting holes diameter | 13.5 mm |
| Circle diameter of the mounting holes | 200 mm |
| Distance shaft shoulder-flange | 73 mm |
| Product weight | 22.5 kg |

Environment

| | |
|---------------------------------------|-----------|
| IP degree of protection | IP65 |
| Ambient air temperature for operation | 0...40 °C |

Contractual warranty

| | |
|----------|-----------|
| Warranty | 18 months |
|----------|-----------|

Dimensions

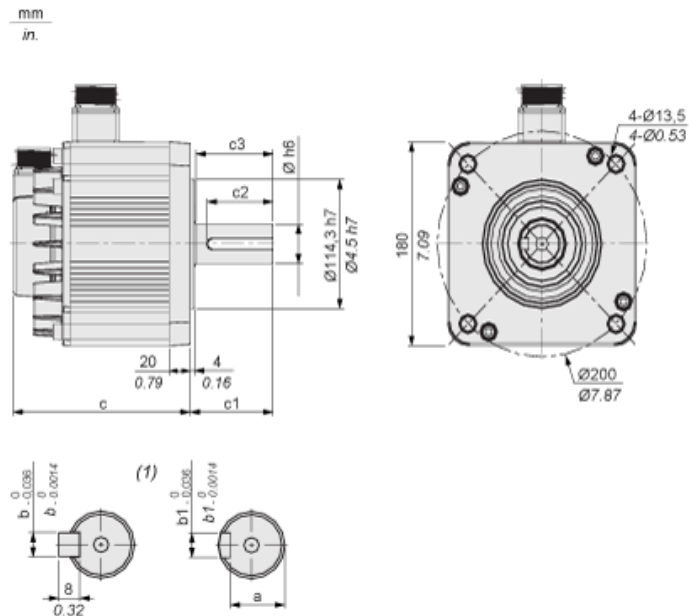

(1) Shaft end, keyed slot (optional)

Dimensions in mm

| Ø | a | b | b1 | c (without holding brake) | c (with holding brake) | c1 | c2 | c3 |
|----|----|----|----|---------------------------|------------------------|----|----|----|
| 35 | 30 | 10 | 10 | 202.1 | 235.3 | 79 | 63 | 73 |

Dimensions in in.

| Ø | a | b | b1 | c (without holding brake) | c (with holding brake) | c1 | c2 | c3 |
|------|------|------|------|---------------------------|------------------------|------|------|------|
| 1.38 | 1.18 | 0.39 | 0.39 | 7.96 | 9.26 | 3.11 | 2.48 | 2.87 |

Torque/Speed Curves with 220 V Three Phase Supply Voltage

Servo Motor with LXM23•U30M3X Servo Drive

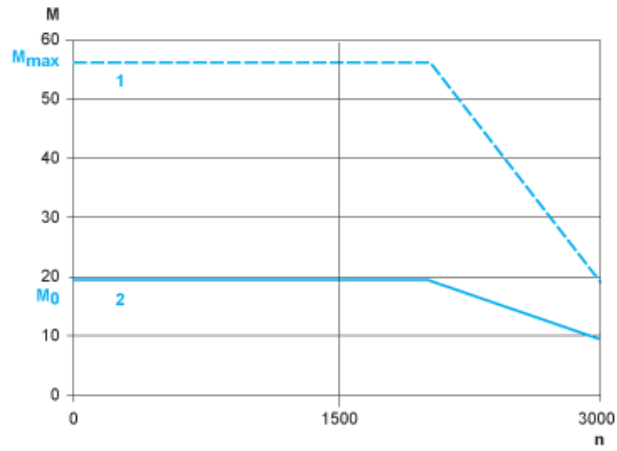

- M : Torque in Nm
- n : Speed in rpm
- 1 : Peak torque
- 2 : Continuous torque