

LXM23AU30M3X

motion servo drive - Lexium 23 - three phase
170...255 V - 3 kW - CAN



⚠ Discontinued

LXM23AU30M3X has not been replaced. Please contact your customer care centre for more information.

Main

Range of product	Lexium 23 Plus
Product or component type	Motion servo drive
Device short name	LXM23

Complementary

Format of the drive	Book
Network number of phases	3 phases
[Us] rated supply voltage	220 V 3 phases (tolerance: - 20...15 %)
Supply voltage limits	170...255 V 3 phases
Supply frequency	50/60 Hz - 5...5 %
Network frequency limits	47.5...63 Hz
Continuous output current	19.4 A
Continuous power	3000 W at 220 V
Nominal power	3 kW at 220 V
Maximum leakage current	3.5 mA
Output voltage	<= power supply voltage
Electrical isolation	Between power and control
Type of cable	Twisted shielded pairs cable (single or double) (temperature: 0...55 °C)
Electrical connection	Terminal, clamping capacity: 1.3 mm ² , AWG 16 (L1-L2) Terminal, clamping capacity: 3.3 mm ² , AWG 12 (R, S, T) Terminal, clamping capacity: 3.3 mm ² , AWG 12 (U, V, W) Terminal, clamping capacity: 3.3 mm ² , AWG 12 (PA/+, PBe)
Tightening torque	PE (ground): 1.4 N.m
Discrete input number	8 programmable discrete input(s)
Discrete input type	Programmable (CN1 terminals)
Discrete input voltage	12...24 V DC for logic
Discrete input logic	Positive or negative (CN1)
Discrete output number	5
Discrete output type	Logic output(s) (CN1)12...24 V DC
Discrete output voltage	12...24 V DC
Analogue input number	2
Absolute accuracy error	0.01 %
Analogue input type	V_REF voltage analog input: - 10...10 V, impedance: 10 kOhm

Disclaimer: This documentation is not intended as a substitute for and is not to be used for determining suitability or reliability of these products for specific user applications

	T_REF voltage analog input: - 10...10 V, impedance: 10 kOhm
Control signal type	Servo motor encoder feedback
Protection type	Against reverse polarity: inputs signal Against short-circuits: outputs signal Overcurrent: motor Overvoltage: motor Undervoltage: motor Overheating: motor Overload: motor Overspeed: motor Abnormal pulse control command: drive
Communication interface	CANopen, integrated CANmotion, integrated
Connector type	RJ45 (CN3) for CANopen, CANopen Motionbus
Method of access	Slave
Physical interface	2-wire RS485 multidrop for Modbus
Transmission rate	125 kbps for bus length of 250...500 m for CANopen, CANmotion 250 kbps for bus length of 100...250 m for CANopen, CANmotion 500 kbps for bus length of 4...100 m for CANopen, CANmotion 1 Mbps for bus length of 4 m for CANopen, CANmotion
Number of addresses	1...127 for CANopen, CANmotion
Status LED	1 LEDcharge LED:
Signalling function	Servo status and fault codes five 7-segment display units
Marking	CE
Type of cooling	Integrated fan
Operating position	Vertical
Width	114 mm
Height	225 mm
Depth	195 mm
Product weight	3.2 kg

Environment

EMC filter	Without EMC filter
Electromagnetic compatibility	EMC immunity level 3 conforming to EN/IEC 61000-4-2 EMC immunity level 3 conforming to EN/IEC 61000-4-3 EMC immunity level 3 conforming to EN/IEC 61000-4-5 EMC immunity level 4 conforming to EN/IEC 61000-4-4 EMC immunity with additional EMC filter conforming to EN/IEC 61800-3 environments 1 and 2 Conducted and radiated emissions with additional EMC filter conforming to EN/IEC 61800-3 environments 1 and 2 category C2, C3
Standards	EN/IEC 61800-5-1
Product certifications	CULus 508 C-Tick
IP degree of protection	On upper part: IP20 (without protective cover) On upper part: IP41 (with protective cover)
Vibration resistance	0.075 mm peak to peak (f= 10...57 Hz) conforming to IEC 60068-2-6 1 gn (f= 57...150 Hz) conforming to IEC 60068-2-6
Shock resistance	15 gn for 11 ms conforming to IEC 60068-2-27
Relative humidity	Class 3K3 (5 to 85 %) without condensation or dripping water conforming to IEC 60721-3-3
Ambient air temperature for operation	0...55 °C conforming to UL
Ambient air temperature for storage	-20...65 °C
Operating altitude	<= 1000 m without > 1000...2000 m with continuous power derating of 1 % per 100 m

Contractual warranty

Warranty	18 months
----------	-----------

Dimensions

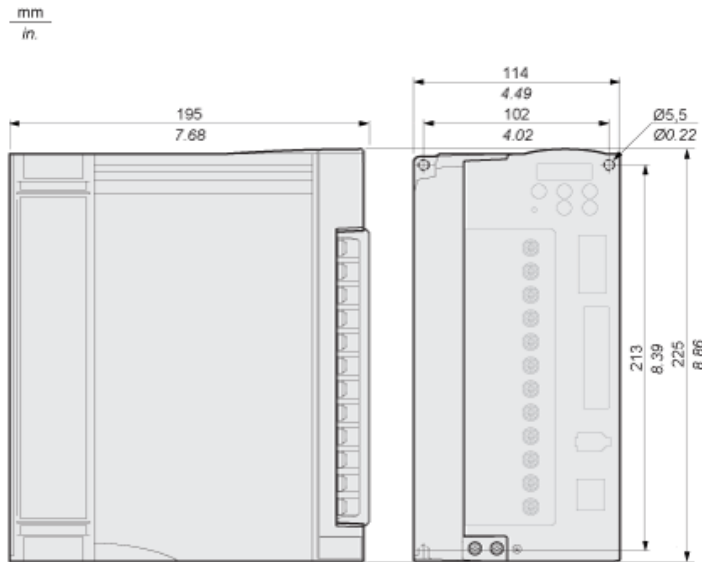

Mounting Recommendations

Mount the device in a vertical position ($\pm 10^\circ$). This is required for cooling the device.

Clearance

Many Devices in a cabinet

$\frac{\text{mm}}{\text{in.}}$

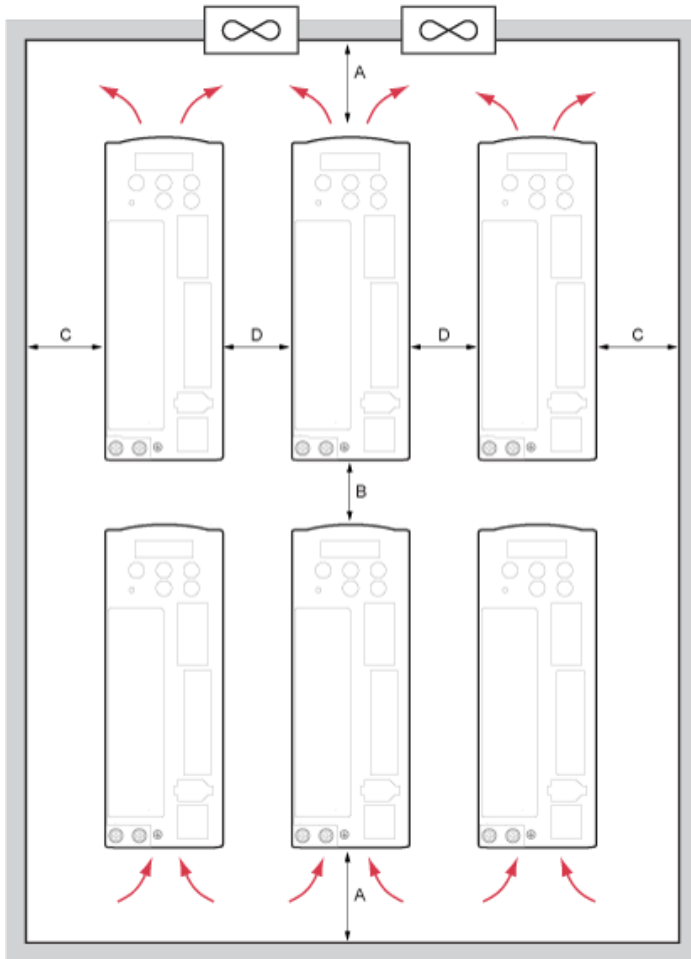

A ≥ 100 mm (≥ 4 in.)	Free space above/below devices
B ≥ 80 mm (≥ 3.2 in.)	Free space between devices
C ≥ 40 mm (≥ 1.6 in.)	Free space between devices and cabinet
D ≥ 10 mm (≥ 0.4 in.)	Free space between devices

One Device in a cabinet

mm
in.

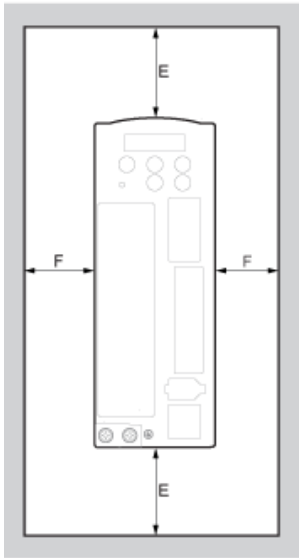

$E \geq 50 \text{ mm} (\geq 2 \text{ in.})$	Free space above/below the device
$F \geq 20 \text{ mm} (\geq 0.8 \text{ in.})$	Free space between device and cabinet

Position Control Mode Wiring Diagram (Pulse Control)

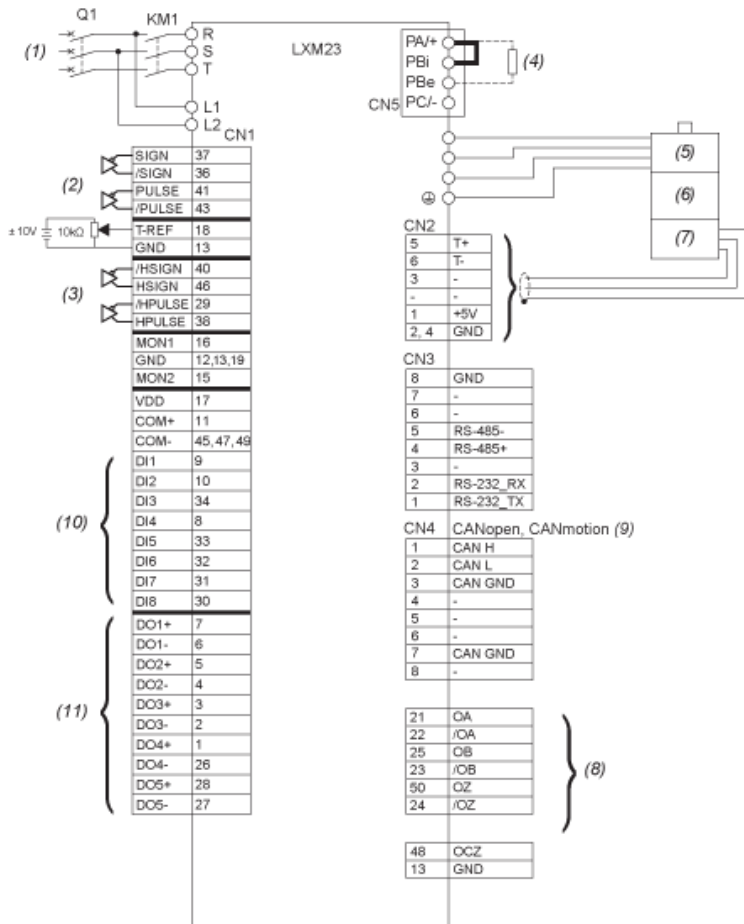

- KM1 Line Contactor
- Q1 Circuit breaker
- (1) AC 220 / 230 V Single Phase or Three Phase 50 / 60 Hz
- (2) Pulse Input (Line Driver)
- (3) High-Speed Pulse Input (Line Receiver)
- (4) External Braking Resistor
- (5) Power Supply
- (6) Holding Brake
- (7) Encoder
- (8) Encoder Pulse Output
- (9) Only LXM23A models
- (10) Digital inputs
- (11) Digital outputs

Position Control Mode Wiring Diagram (Build-In Motion Sequence)

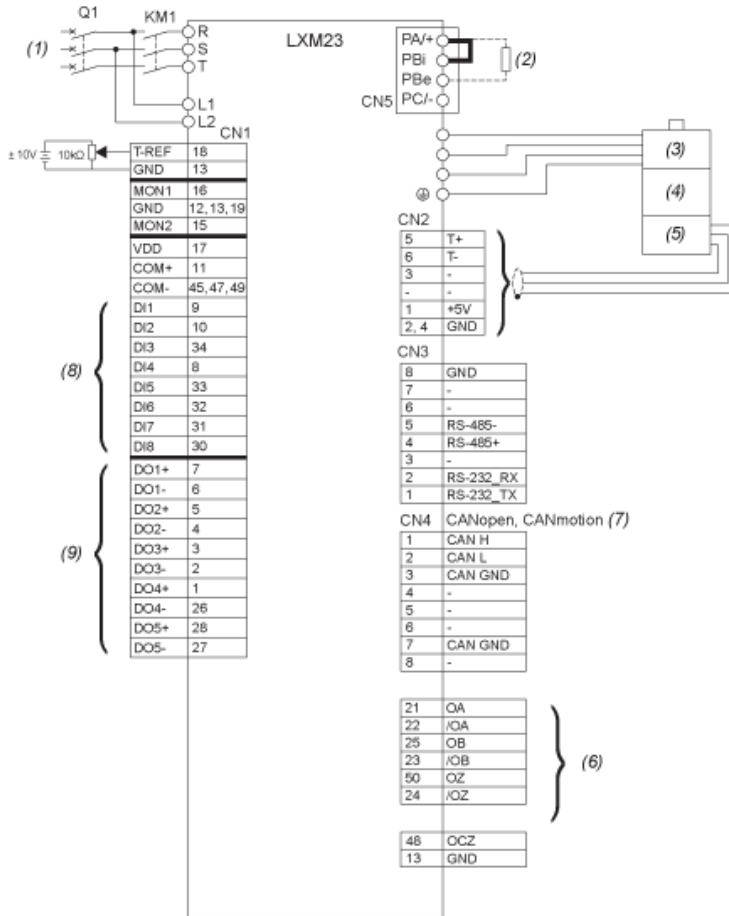

- KM1 Line Contactor
- Q1 Circuit breaker
- (1) AC 220 / 230 V Single Phase or Three Phase 50 / 60 Hz
- (2) External Braking Resistor
- (3) Power Supply
- (4) Holding Brake
- (5) Encoder
- (6) Encoder Pulse Output
- (7) Only LXM23A models
- (8) Digital inputs
- (9) Digital outputs

Speed Control Mode Wiring Diagram

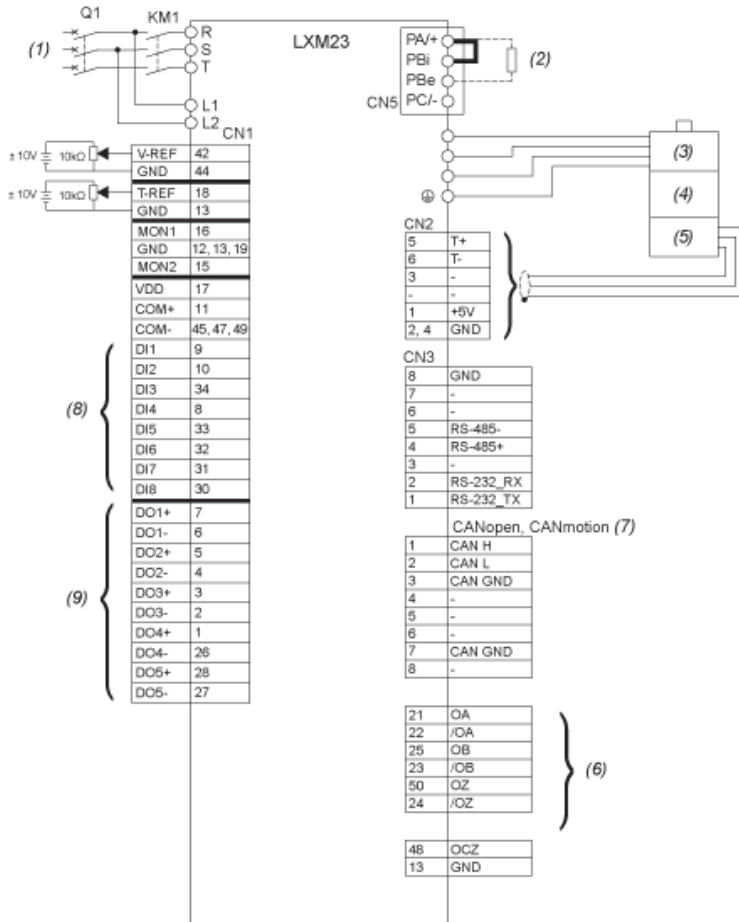

- KM1 Line Contactor
- Q1 Circuit breaker
- (1) AC 220 / 230 V Single Phase or Three Phase 50 / 60 Hz
- (2) External Braking Resistor
- (3) Power Supply
- (4) Holding Brake
- (5) Encoder
- (6) Encoder Pulse Output
- (7) Only LXM23A models
- (8) Digital inputs
- (9) Digital outputs

Torque Control Mode Wiring Diagram

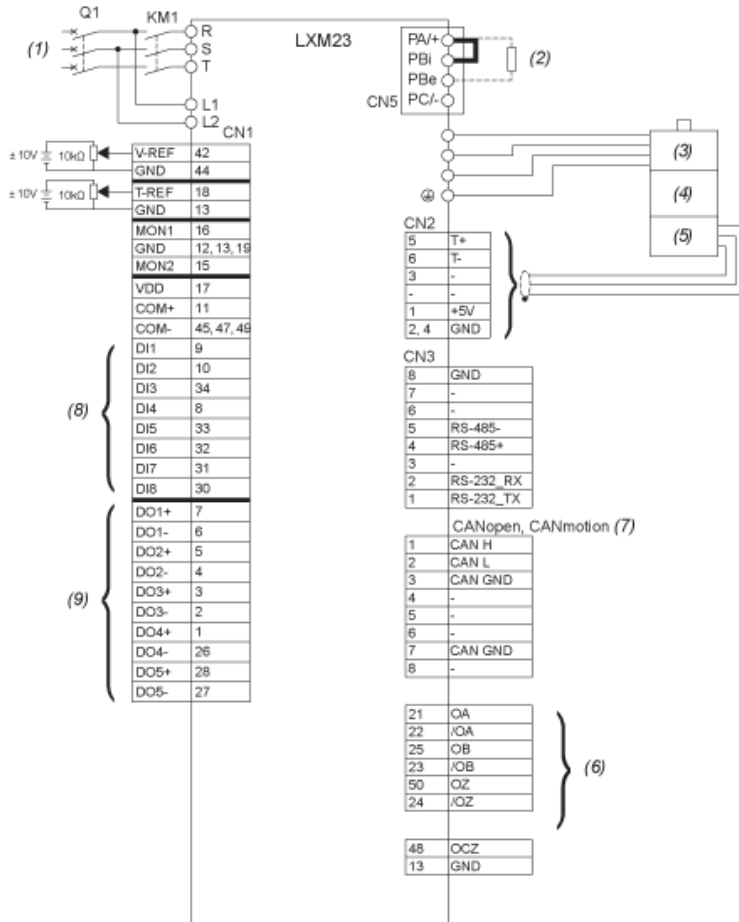

- KM1 Line Contactor
- Q1 Circuit breaker
- (1) AC 220 / 230 V Single Phase or Three Phase 50 / 60 Hz
- (2) External Braking Resistor
- (3) Power Supply
- (4) Holding Brake
- (5) Encoder
- (6) Encoder Pulse Output
- (7) Only LXM23A models
- (8) Digital inputs
- (9) Digital outputs

CANopen Control Mode Wiring Diagram

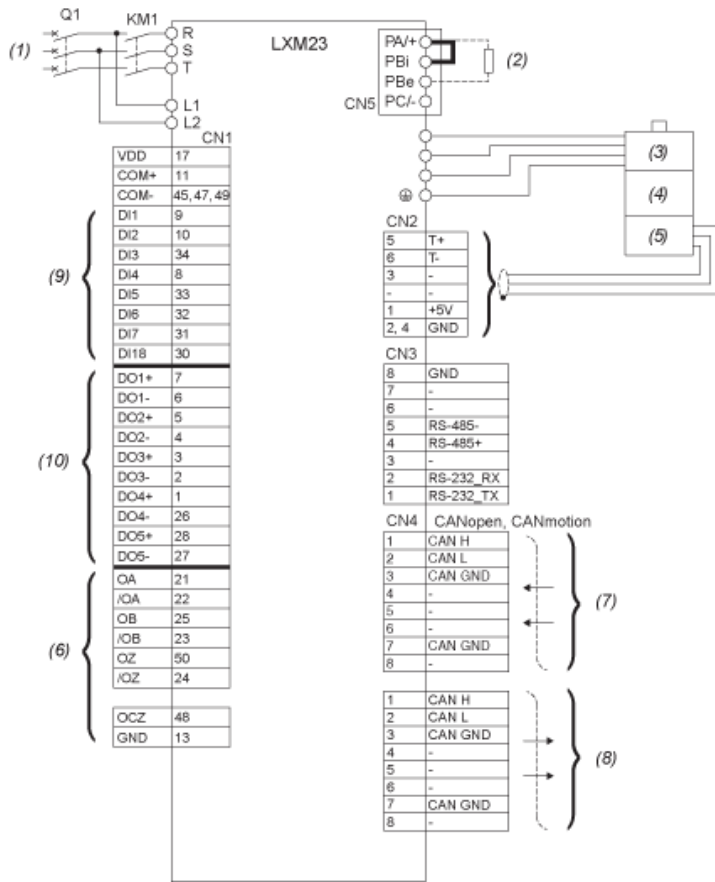

- KM1 Line Contactor
- Q1 Circuit breaker
- (1) AC 220 / 230 V Single Phase or Three Phase 50 / 60 Hz
- (2) External Braking Resistor
- (3) Power Supply
- (4) Holding Brake
- (5) Encoder
- (6) Encoder Pulse Output
- (7) Data Input
- (8) Data Output
- (9) Digital inputs
- (10) Digital outputs