

Main

Range compatibility	Lexium 28
Product or component type	Servo motor
Device short name	BCH2

Complementary

Maximum mechanical speed	3000 rpm
[Us] rated supply voltage	220 V
Network number of phases	Three phase Single phase
Continuous stall current	6.18 A
Continuous stall torque	7.16 N.m for LXM28... at 7 A, 220 V, single phase 7.16 N.m for LXM28... at 7 A, 220 V, three phase
Continuous power	1500 W
Peak stall torque	21.48 N.m for LXM28... at 7 A, 220 V, single phase 21.48 N.m for LXM28... at 7 A, 220 V, three phase
Nominal output power	1500 W for LXM28... at 7 A, 220 V, single phase 1500 W for LXM28... at 7 A, 220 V, three phase
Nominal torque	7.16 N.m for LXM28... at 7 A, 220 V, single phase 7.16 N.m for LXM28... at 7 A, 220 V, three phase
Nominal speed	2000 rpm for LXM28... at 7 A, 220 V, single phase 2000 rpm for LXM28... at 7 A, 220 V, three phase
Maximum current Irms	20.31 A for LXM28... at 1.5 kW, 220 V
Maximum permanent current	6.74 A
Product compatibility	LXM28... servo drive motor at 1.5 kW, 220 V, single phase LXM28... servo drive motor at 1.5 kW, 220 V, three phase
Shaft end	Keyed
Shaft diameter	22 mm
Shaft length	55 mm
Key width	8 mm
Feedback type	20 bits single turn absolute encoder
Holding brake	With
Holding torque	9.6 N.m built-in
Mounting support	Asian standard flange

Disclaimer: This documentation is not intended as a substitute for and is not to be used for determining suitability or reliability of these products for specific user applications

Motor flange size	130 mm
Electrical connection	Connector MIL
Torque constant	1.16 N.m/A at 20 °C
Back emf constant	70 V/krpm at 20 °C
Rotor inertia	10 kg.cm ²
Stator resistance	0.64 Ohm at 20 °C
Stator inductance	6.4 mH at 20 °C
Stator electrical time constant	10 ms at 20 °C
Maximum radial force Fr	670 N at 2000 rpm
Maximum axial force Fa	200 N
Brake pull-in power	19.7 W
Type of cooling	Natural convection
Length	202 mm
Number of motor stacks	3
Centring collar diameter	110 mm
Centring collar depth	8 mm
Number of mounting holes	4
Mounting holes diameter	9.2 mm
Circle diameter of the mounting holes	145 mm
Distance shaft shoulder-flange	8 mm
Product weight	8.8 kg

Environment

IP degree of protection	IP54 IM B5, IM V1 IP50 IM V3
Ambient air temperature for operation	0...40 °C

Contractual warranty

Warranty	18 months
----------	-----------

Dimensions

Dimensions of Motor

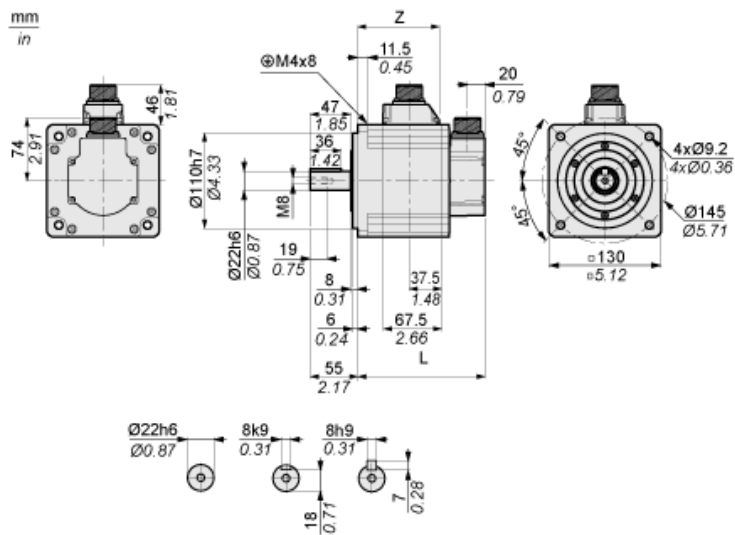

	mm	in.
L (without holding brake)	167	6.57
L (with holding brake)	202	7.95
Z	114.5	4.51

Torque/Speed Curves with 230 V Single/Three Phase Supply Voltage

Servo Motor with LXM28AU15 Servo Drive

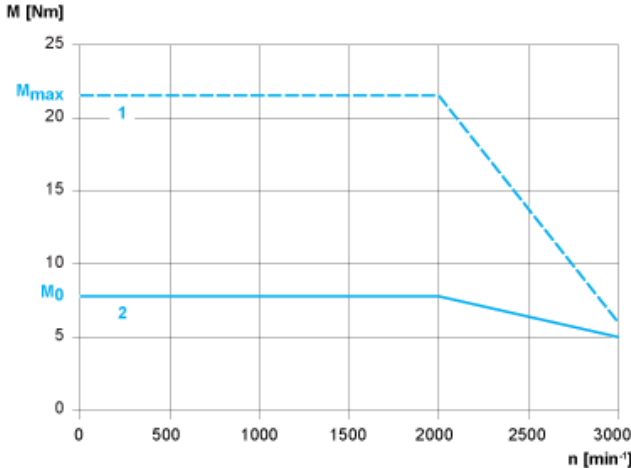

- 1 : Peak torque
- 2 : Continuous torque