



Main

Range compatibility	Lexium 28
Product or component type	Servo motor
Device short name	BCH2

Complementary

Maximum mechanical speed	3000 rpm
[Us] rated supply voltage	220 V
Network number of phases	Three phase
Continuous stall current	9.95 A
Continuous stall torque	9.55 N.m for LXM26D at 12 A, 220 V, three phase 9.55 N.m for LXM28... at 12 A, 220 V, three phase 9.55 N.m
Continuous power	2000 W
Peak stall torque	28.65 N.m for LXM26D at 12 A, 220 V, three phase 28.65 N.m for LXM28... at 12 A, 220 V, three phase 28.65 N.m
Nominal output power	2000 W for LXM26D at 12 A, 220 V, three phase 2000 W for LXM28... at 12 A, 220 V, three phase 2000 W
Nominal torque	9.55 N.m for LXM26D at 12 A, 220 V, three phase 9.55 N.m for LXM28... at 12 A, 220 V, three phase 9.55 N.m
Nominal speed	2000 rpm 2000 rpm for LXM26D at 12 A, 220 V, three phase 2000 rpm for LXM28... at 12 A, 220 V, three phase
Maximum current Irms	32.85 A for LXM28... at 2 kW, 220 V 32.85 A at 2 kW, 220 V
Maximum permanent current	11.25 A
Product compatibility	LXM26D servo drive motor at 2 kW, 220 V, three phase LXM28... servo drive motor at 2 kW, 220 V, three phase
Shaft end	Keyed

Shaft diameter	22 mm
Shaft length	55 mm
Key width	8 mm
Feedback type	20 bits single turn absolute encoder
Holding brake	Without
Mounting support	Asian standard flange
Motor flange size	130 mm
Electrical connection	Connector MIL
Torque constant	0.96 N.m/A at 20 °C
Back emf constant	58 V/krpm at 20 °C
Rotor inertia	13.5 kg.cm ²
Stator resistance	0.34 Ohm at 20 °C
Stator inductance	4.5 mH at 20 °C
Stator electrical time constant	13.24 ms at 20 °C
Maximum radial force Fr	670 N at 2000 rpm
Maximum axial force Fa	200 N
Brake pull-in power	19.7 W
Type of cooling	Natural convection
Length	187 mm
Number of motor stacks	4
Centring collar diameter	110 mm
Centring collar depth	8 mm
Number of mounting holes	4
Mounting holes diameter	9.2 mm
Circle diameter of the mounting holes	145 mm
Distance shaft shoulder-flange	8 mm
Product weight	9.7 kg

Environment

IP degree of protection	IP50 IM V3 IP65 IM B5, IM V1
Ambient air temperature for operation	-20...40 °C

Offer Sustainability

Sustainable offer status	Green Premium product
REACH Regulation	REACH Declaration
REACH free of SVHC	Yes
EU RoHS Directive	Pro-active compliance (Product out of EU RoHS legal scope) EU RoHS Declaration
Mercury free	Yes
RoHS exemption information	Yes
China RoHS Regulation	China RoHS declaration
Environmental Disclosure	Product Environmental Profile
Circularity Profile	No need of specific recycling operations
WEEE	The product must be disposed on European Union markets following specific waste collection and never end up in rubbish bins

Contractual warranty

Warranty	18 months
----------	-----------

Dimensions

Dimensions of Motor

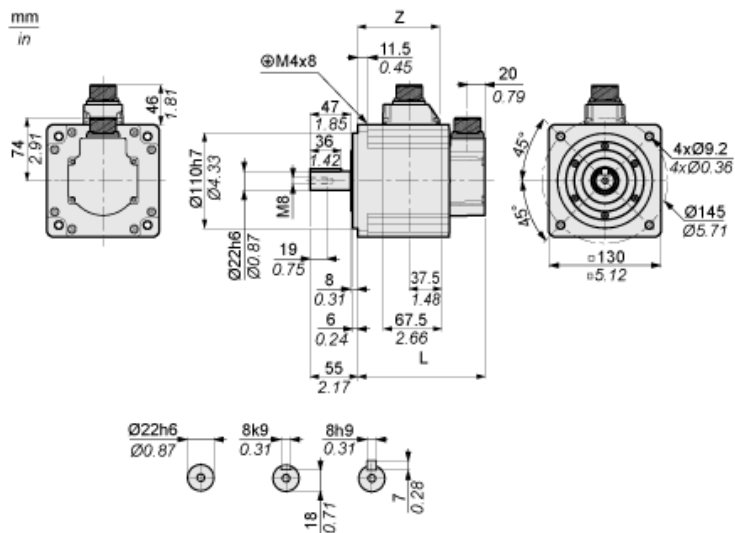

	mm	in.
L (without holding brake)	187	7.36
L (with holding brake)	216	8.5
Z	134.5	5.30

Torque/Speed Curves with 230 V Three Phase Supply Voltage

Servo Motor with LXM28AU20●●● Servo Drive

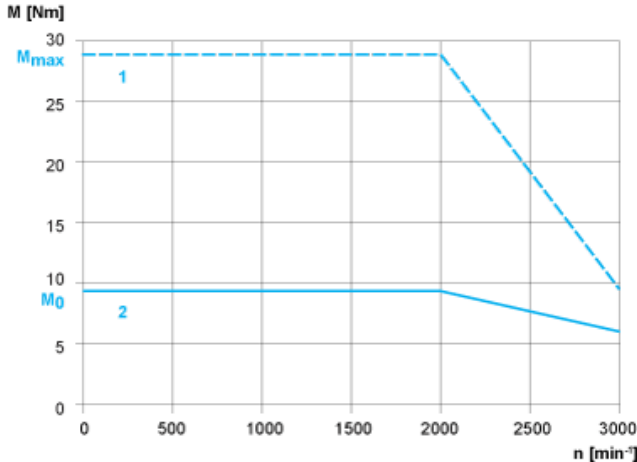

- 1 : Peak torque
- 2 : Continuous torque