

## Main

Range compatibility	Lexium SD3
Product or component type	Motion control motor
Device short name	BRS3
Maximum mechanical speed	3000 rpm
Motor type	3-phase stepper motor
Number of motor poles	6
Supply voltage limits	230 V AC 325 V DC
Mounting support	Flange
Motor flange size	85 mm
Length	187 mm
Centring collar diameter	60 mm

## Complementary

Centring collar depth	2 mm
Number of mounting holes	4
Mounting holes diameter	6.5 mm
Circle diameter of the mounting holes	98.99 mm
Electrical connection	Terminal box
Holding brake	With
Shaft end	Untapped
Second shaft	Without second shaft end
Shaft diameter	12 mm
Shaft length	30 mm
Nominal torque	4 N.m
Peak stall torque	3.82 N.m
Continuous stall torque	3.82 N.m

Holding torque	4.52 N.m
Rotor inertia	2.2 kg.cm <sup>2</sup>
Resolution	1.8 °, 0.9 °, 0.72 °, 0.36 °, 0.18 °, 0.09 °, 0.072 °, 0.036 ° step angle 200, 400, 500, 1000, 2000, 4000, 5000, 10000 steps number of full steps per revolution
Accuracy error	+/- 6 arc min
Maximum starting frequency	5.3 kHz
[In] rated current	2 A
Resistance	5.8 Ohm (winding)
Time constant	9 ms
Maximum radial force Fr	100 N (first shaft end) 50 N (second shaft end)
Maximum axial force Fa	175 N (tensile force) 30 N (force pressure)
Service life in hours	20000 h (bearing)
Angular acceleration	200000 rad/s <sup>2</sup>
Product weight	3.2 kg

## Environment

Standards	EN 50347 IEC 60072-1
Type of cooling	Natural convection
Ambient air temperature for operation	-25...40 °C
Ambient air temperature for storage	-25...70 °C
Operating altitude	<= 1000 m without power derating
Relative humidity	15...85 % without condensation
Vibration resistance	20 m/s <sup>2</sup> maximum A conforming to EN/IEC 60034-14
IP degree of protection	IP56 shaft bushing: conforming to EN/IEC 60034-5 IP56 total except shaft bushing: conforming to EN/IEC 60034-5
Temperature class	F winding conforming to IEC/EN 60034-1

## Offer Sustainability

Sustainable offer status	Green Premium product
REACH Regulation	<a href="#">REACH Declaration</a>
REACH free of SVHC	Yes
EU RoHS Directive	Pro-active compliance (Product out of EU RoHS legal scope) <a href="#">EU RoHS Declaration</a>
Mercury free	Yes
RoHS exemption information	<a href="#">Yes</a>
China RoHS Regulation	<a href="#">China RoHS declaration</a>
Environmental Disclosure	<a href="#">Product Environmental Profile</a>
Circularity Profile	No need of specific recycling operations
WEEE	The product must be disposed on European Union markets following specific waste collection and never end up in rubbish bins

## Contractual warranty

Warranty	18 months
----------	-----------

Dimensions

3-Phase Stepper Motor in Terminal Box Version

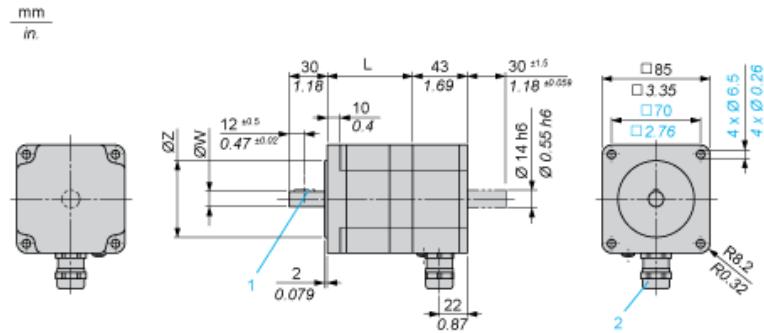

Holding Brake

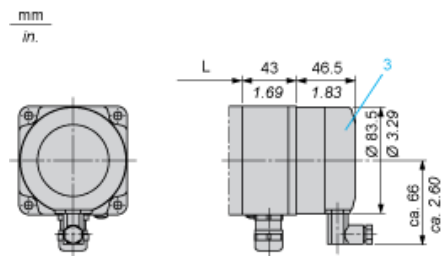

3 : Holding brake (optional)

Dimensions in mm

L	Shaft diameter ØW	Centring collar ØZ	Woodruff key DIN 6888 (1)	Cable gland (2)
97.5 (+0.6) (-0.8)	12 h6	60 h8	4 x 6.5	ISO M20 x 1.5

Dimensions in in.

L	Shaft diameter ØW	Centring collar ØZ	Woodruff key DIN 6888 (1)	Cable gland (2)
3.84 (+0.023) (-0.031)	0.47 h6	2.36 h8	0.16 x 0.25	ISO M20 x 1.5

Wiring Diagram of Holding Brake

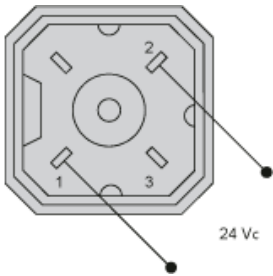

The connector is part of the scope of delivery. Connector designation: Hirschmann type G4 A 5M

Torque Characteristics

Measurement at 1000 Steps/Revolution, Nominal Voltage DC Bus  $U_N$  and Phase Current  $I_N$

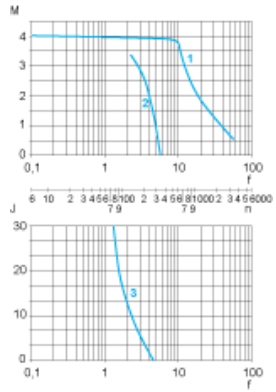

- M : Torque in Nm
- n : Speed in rpm
- f : Frequency in kHz
- J : Rotor inertia in kg.cm<sup>2</sup>
- 1 : Pull-out torque
- 2 : Pull-in torque
- 3 : Maximum load inertia