



Price* : 7.96 GBP



Main

Range of product	Harmony XVM
Accessory / separate part designation	Ø 20 mm aluminium support tube with metal bracket
Accessory / separate part category	Mounting and fixing accessories
Accessory / separate part destination	Beacons and indicator banks Ø 45 mm

Complementary

Accessory / separate part type	Support tube with bracket
Product compatibility	XVM.
Colour	Aluminium
Height under base unit	113 mm
Length	100 mm
Product weight	0.198 kg

Offer Sustainability

Sustainable offer status	Green Premium product
EU RoHS Directive	Pro-active compliance (Product out of EU RoHS legal scope) EU RoHS Declaration
Mercury free	Yes
RoHS exemption information	Yes
China RoHS Regulation	China RoHS declaration
Environmental Disclosure	Product Environmental Profile
Circularity Profile	No need of specific recycling operations

Contractual warranty

Warranty	18 months
----------	-----------

Dimensions and Mounting

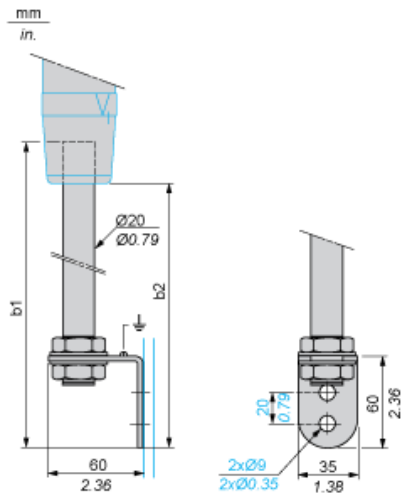

Support tube length		b1 (tube + plate)		b2 (height under base unit)	
mm	in.	mm	in.	mm	in.
100	3.94	133	5.24	106	4.17

Panel Cut-Out

