

TM3SAC5R

SAFETY MODULE FOR PLC TM2xx, 1 FUNCTION, CAT3, SCREW TERMINALS



Price* : 131.00 GBP



Main

Range of product	Modicon TM3 Safety
Product or component type	Safety module
Device short name	TM3SAC
Safety module application	For emergency stop and switch monitoring
Function of module	Emergency stop monitoring 1-channel wiring Emergency stop monitoring 2-channel wiring Monitoring of a movable guard with 2 switches and automatic start
Safety level	Can reach PL d/category 3 conforming to EN/ISO 13849-1: 2008 Can reach PL d/category 3 conforming to EN/ISO 13849-2: 2012 Can reach SILCL 2 conforming to EN/IEC 62061: 2005 Can reach SIL 2 conforming to EN/IEC 61508: 2010

Complementary

Safety reliability data	DC = 95 % conforming to EN/ISO 13849-1 PFHd = 5E-9 1/h conforming to IEC 61508-1 1 operation/hour DC-13 24 V DC, <4 A PFHd = 30E-9 1/h conforming to IEC 61508-1 60 operations/hour DC-13 24 V DC, <1 A MTTFd = 500 years conforming to EN/ISO 13849-1 1 operation/hour DC-13 24 V DC, <4 A MTTFd = 85 years conforming to EN/ISO 13849-1 60 operations/hour DC-13 24 V DC, <1 A SFF = 95 % conforming to IEC 61508-1 HFT = 1 conforming to IEC 61508-1 Type = A conforming to IEC 61508-1
Synchronisation time between inputs	Unlimited
Connections - terminals	Captive screw clamp terminals, removable terminal block 1 x 0.2...1 x 2.5 mm ² flexible without cable end 13-14, 23-24, 33-34 Captive screw clamp terminals, removable terminal block 1 x 0.2...1 x 2.5 mm ² solid without cable end 13-14, 23-24, 33-34 Captive screw clamp terminals, removable terminal block 1 x 0.25...1 x 2.5 mm ² flexible with cable end, with bezel 13-14, 23-24, 33-34 Captive screw clamp terminals, removable terminal block 1 x 0.25...1 x 2.5 mm ² flexible with cable end, without bezel 13-14, 23-24, 33-34 Captive screw clamp terminals, removable terminal block 2 x 0.2...2 x 1.5 mm ² flexible without cable end 13-14, 23-24, 33-34 Captive screw clamp terminals, removable terminal block 2 x 0.2...2 x 1.5 mm ² solid without cable end 13-14, 23-24, 33-34

Captive screw clamp terminals, removable terminal block 2 x 0.25...2 x 1 mm² flexible with cable end, without bezel 13-14, 23-24, 33-34
 Captive screw clamp terminals, removable terminal block 2 x 0.5...2 x 1.5 mm² flexible with cable end, with double bezel 13-14, 23-24, 33-34
 Captive screw clamp terminals, removable terminal block 1 x 0.14...1 x 1.5 mm² flexible without cable end other terminals
 Captive screw clamp terminals, removable terminal block 1 x 0.14...1 x 1.5 mm² solid without cable end other terminals
 Captive screw clamp terminals, removable terminal block 1 x 0.25...1 x 0.5 mm² flexible with cable end, with bezel other terminals
 Captive screw clamp terminals, removable terminal block 1 x 0.25...1 x 1.5 mm² flexible with cable end, without bezel other terminals
 Captive screw clamp terminals, removable terminal block 2 x 0.14...2 x 0.5 mm² flexible without cable end other terminals
 Captive screw clamp terminals, removable terminal block 2 x 0.14...2 x 0.75 mm² solid without cable end other terminals
 Captive screw clamp terminals, removable terminal block 2 x 0.25...2 x 0.34 mm² flexible with cable end, without bezel other terminals
 Captive screw clamp terminals, removable terminal block 2 x 0.5 mm² flexible with cable end, with double bezel other terminals

Output type	Relay instantaneous opening, 3 NO circuit(s), potential free
Number of safety circuits	3 NO for relay instantaneous opening
Maximum switching voltage	230 V utilisation category AC-15 at 50 Hz (relay instantaneous opening) 24 V utilisation category DC-13 (relay instantaneous opening)
[Us] rated supply voltage	24 V - 15...20 % DC
Power consumption in W	0.2 W at 5 V DC 3.6 W at 24 V DC
Input protection type	Internal, electronic
[Uc] control circuit voltage	24 V DC
Maximum cable distance between devices	30 m
Breaking capacity	360 VA holding AC-15 B300 relay output 3600 VA inrush AC-15 B300 relay output
Breaking capacity	4 A 24 V 50 ms DC-13 relay output
Output thermal current	6 A per relay for relay output
[Ith] conventional free air thermal current	18 A
Associated fuse rating	4 A gG or gL for relay output conforming to EN/IEC 60947-5-1 6 A fast blow for relay output conforming to EN/IEC 60947-5-1
Minimum output current	10 mA for relay output
Output voltage	10 V relay output
Maximum response time on input open	40 ms
[Ui] rated insulation voltage	300 V (pollution degree 2) conforming to IEC 60647-5-1
[Uimp] rated impulse withstand voltage	4 kV overvoltage category III conforming to IEC 60647-5-1
Current consumption	100 mA at 24 V DC external supply (at state on)
Local signalling	6 LEDs (green/red)user:
Electrical connection	Screw terminal
Standards	EN/ISO 13849-1:2008 EN/ISO 13849-2:2012 EN/IEC 62061:2005 EN/IEC 61508:2010 EN/IEC 60947-5-1:2010 EN/IEC 61131-2:2007 EN/IEC 60204-1:2005 EN/IEC 60204-1:2009/A1 IEC 61010-1:2010 EN 50581:2012
Product certifications	TÜV CSA 61010-2-201 (pending) CSA Haz Loc Class 1 Division 2 (pending) RCM ANSI Haz Loc Class 1 Division 2 (pending) EAC UL 61010-2-201

Marking	EFUP 10 RCM CSA UL TÜV CE REACH EAC
Electromagnetic compatibility	Electrostatic discharge immunity test - test level: 8 kV (air discharge) conforming to EN/IEC 61000-4-2 Electrostatic discharge immunity test - test level: 6 kV (contact discharge) conforming to EN/IEC 61000-4-2 Susceptibility to electromagnetic fields - test level: 10 V/m (80 MHz to 1 GHz) conforming to EN/IEC 61000-4-3 Susceptibility to electromagnetic fields - test level: 3 V/m (1.4 GHz...2 GHz) conforming to EN/IEC 61000-4-3 Susceptibility to electromagnetic fields - test level: 1 V/m (2 GHz...3 GHz) conforming to EN/IEC 61000-4-3 Magnetic field at power frequency - test level: 30 A/m (50...60 Hz) conforming to EN/IEC 61000-4-8 Electrical fast transient/burst immunity test - test level: 3 kV (power lines (DC)) conforming to EN/IEC 61000-4-4 Electrical fast transient/burst immunity test - test level: 2 kV (I/O) conforming to EN/IEC 61000-4-4 1.2/50 µs shock waves immunity test - test level: 1 kV (power lines (DC)) conforming to EN/IEC 61000-4-5 Conducted RF disturbances - test level: 10 V (0.15...80 MHz) conforming to EN/IEC 61000-4-6 Radiated emission - test level: 40 dBµV/m class A (24 V) conforming to EN 55011 Radiated emission - test level: 47 dBµV/m class A (24 V) conforming to EN 55011
Mounting support	Top hat type TH35-7.5 rail conforming to IEC 60715 Top hat type TH35-15 rail conforming to IEC 60715 wall mount using attached fasteners
Height	94 mm
Depth	73 mm
Width	43.7 mm
Product weight	0.19 kg

Environment

Standards	EN 1088/ISO 14119 EN/ISO 13850 EN/IEC 60947-1 EN 60204-1 EN/IEC 60947-5-1
Resistance to electrostatic discharge	8 kV in air conforming to EN/IEC 61000-4-2 6 kV on contact conforming to EN/IEC 61000-4-2
Resistance to electromagnetic fields	10 V/m 80 MHz...1 GHz conforming to EN/IEC 61000-4-3 3 V/m 1.4 GHz...2 GHz conforming to EN/IEC 61000-4-3 1 V/m 2 GHz...3 GHz conforming to EN/IEC 61000-4-3
Resistance to magnetic fields	30 A/m 50/60 Hz conforming to EN/IEC 61000-4-8
Resistance to fast transients	3 kV for power lines (DC) (DC) conforming to EN/IEC 61000-4-4 2 kV for I/O lines conforming to EN/IEC 61000-4-4
Surge withstand	1 kV power lines (DC) differential mode conforming to EN/IEC 61000-4-5 DC 1 kV power lines (DC) common mode conforming to EN/IEC 61000-4-5 DC
Resistance to conducted disturbances	10 V 0.15...80 MHz conforming to EN/IEC 61000-4-6
Electromagnetic emission	Radiated emissions - test level: 50 dBµV/m class A (24 V DC) at 30...230 Hz conforming to IEC 61131-3 Radiated emissions - test level: 57 dBµV/m class A (24 V DC) at 230...1000 Hz conforming to IEC 61131-3
Ambient air temperature for operation	-10...55 °C horizontal installation
Ambient air temperature for storage	-25...70 °C
Relative humidity	10...95 %, without condensation (in operation) 10...95 %, without condensation (in storage)
IP degree of protection	IP20 (terminals) conforming to EN/IEC 60529
Pollution degree	2
Operating altitude	0...2000 m
Storage altitude	0...3000 m
Vibration resistance	+/- 3.5 mm (f= 5...150 Hz) conforming to IEC 60068-2-6

Shock resistance	15 gn for 11 ms conforming to IEC 60068-2-27
Mechanical robustness	Bumps 6 ms 300 shocks (25 gn) conforming to IEC 60068-2-27

Offer Sustainability

Sustainable offer status	Green Premium product
REACH Regulation	REACH Declaration
REACH free of SVHC	Yes
EU RoHS Directive	Pro-active compliance (Product out of EU RoHS legal scope) EU RoHS Declaration
Mercury free	Yes
RoHS exemption information	Yes
China RoHS Regulation	China RoHS declaration
Environmental Disclosure	Product Environmental Profile
Circularity Profile	End of Life Information
WEEE	The product must be disposed on European Union markets following specific waste collection and never end up in rubbish bins

Contractual warranty

Warranty	18 months
----------	-----------

Dimensions

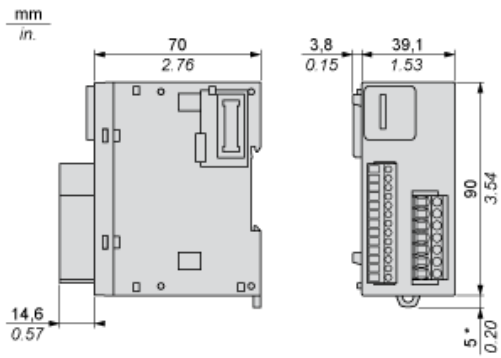

(*) 8.5 mm/0.33 in when the clamp is pulled out.

Spacing Requirements

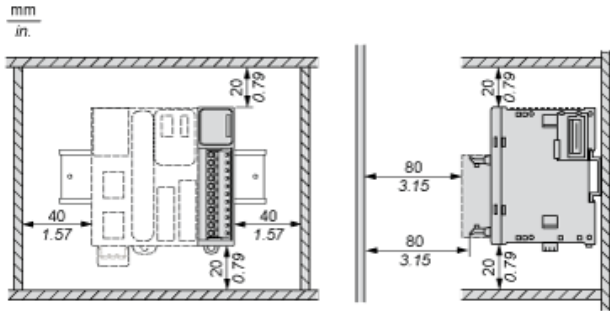

Mounting on a Rail

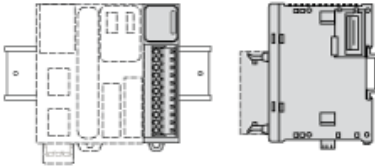

Incorrect Mounting

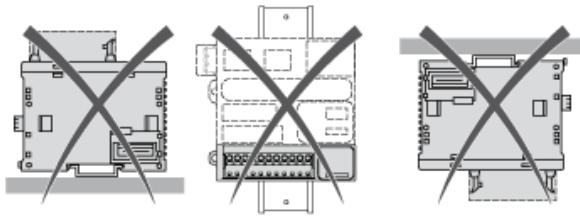

Mounting on a Panel Surface

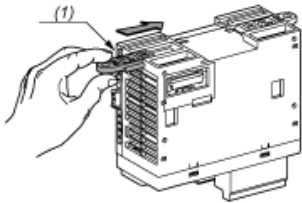

(1) Install a mounting strip

Mounting Hole Layout

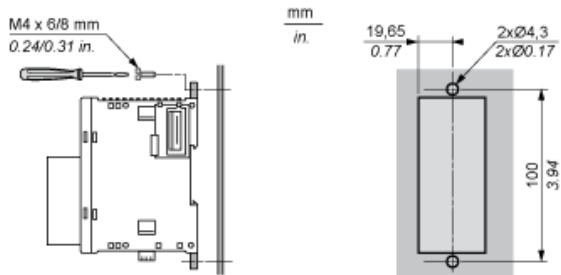

Emergency Stop Wiring Diagram

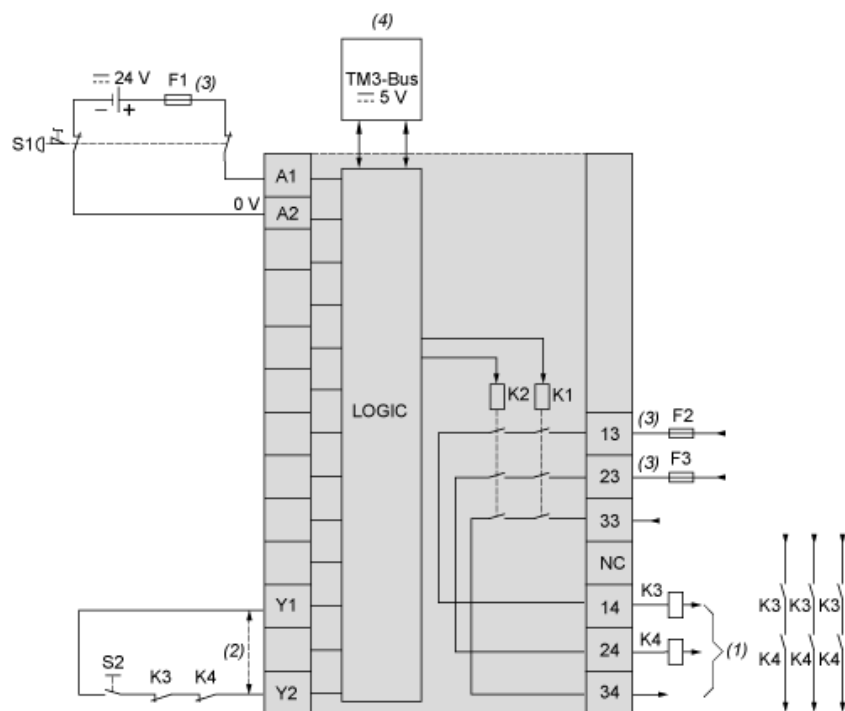

- S1 : Emergency stop switch
- S2 : Start switch
- (1) Safety outputs
- (2) For automatic start, directly connect [Y1] and [Y2] terminals
- (3) Fuses. Refer to technical specifications for fuse values
- (4) Non-safety related TM3 Bus communication with logic controller