



**Model Number**

**ML100-54-F/25/103/115a/154**

Retroreflective sensor  
with 300 mm fixed cable and 4-pin, M8 x 1  
connector

**Features**

- No controls
- Miniature design
- Easy to use
- Clearly visible LEDs for Power ON, switching state and weak signal indication
- Very bright, highly visible light spot
- Full metal thread mounting
- Not sensitive to ambient light

**Product information**

The ML100 series is characterized by its miniature housing with integral, all-metal threaded bushings. All versions are equipped with a visible red transmitter LED. This greatly simplifies installation and commissioning. The switching states are easily visible from all directions thanks to the highly visible LEDs.

Release date: 2019-05-29 08:46 Date of issue: 2019-05-29 70105368\_eng.xml

**Dimensions**

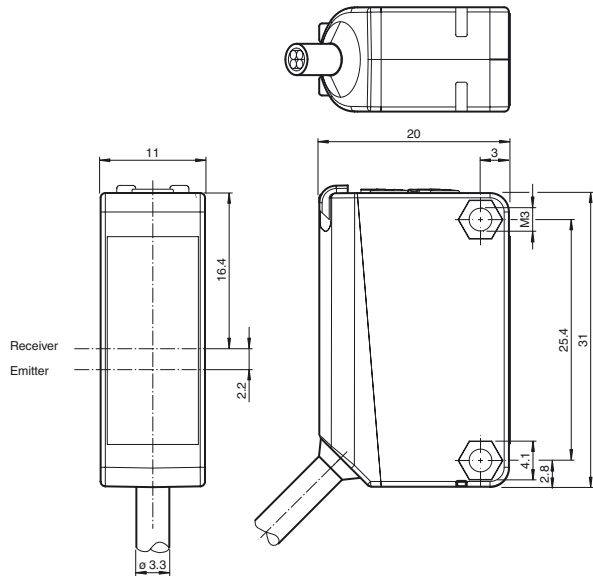

**Electrical connection**

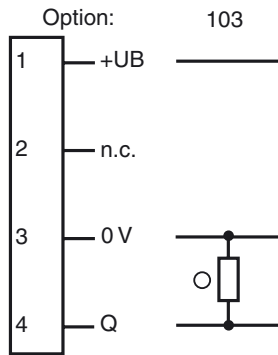

○ = Light on  
● = Dark on

**Pinout**

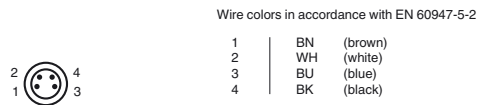

**Indicators/operating means**

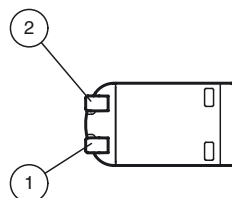

1	Signal display	yellow
2	Operating display	green

**Technical data****General specifications**

Effective detection range	0 ... 2.7 m
Reflector distance	0.02 ... 2.7 m
Threshold detection range	3 m
Reference target	H50 reflector
Light source	LED
Light type	modulated visible red light
Polarization filter	yes
Diameter of the light spot	approx. 200 mm at a distance of 3 m
Angle of divergence	approx. 4 °
Optical face	frontal
Ambient light limit	EN 60947-5-2

**Functional safety related parameters**

MTTF <sub>d</sub>	860 a
Mission Time (T <sub>M</sub> )	20 a
Diagnostic Coverage (DC)	0 %

**Indicators/operating means**

Operation indicator	LED green: power on
Function indicator	LED yellow: lights up when receiving the light beam ; flashes when falling short of the stability control; OFF when light beam is interrupted

**Electrical specifications**

Operating voltage	U <sub>B</sub>	10 ... 30 V DC
Ripple		max. 10 %
No-load supply current	I <sub>0</sub>	< 20 mA

**Output**

Switching type	light on	
Signal output	1 PNP output, short-circuit protected, reverse polarity protected, open collector	
Switching voltage	max. 30 V DC	
Switching current	max. 100 mA , resistive load	
Voltage drop	U <sub>d</sub>	≤ 1.5 V DC
Switching frequency	f	1000 Hz
Response time		0.5 ms

**Ambient conditions**

Ambient temperature	-30 ... 60 °C (-22 ... 140 °F)
Storage temperature	-40 ... 70 °C (-40 ... 158 °F)

**Mechanical specifications**

Housing width	11 mm
Housing height	31 mm
Housing depth	20 mm
Degree of protection	IP67
Connection	300 mm fixed cable with 4-pin, M8 x 1 connector
Material	
Housing	PC (Polycarbonate)
Optical face	PMMA
Mass	approx. 20 g
Tightening torque, fastening screws	0.6 Nm
Cable length	0.3 m

**Compliance with standards and directives**

Directive conformity	
EMC Directive 2004/108/EC	EN 60947-5-2
Standard conformity	
Standards	UL 60947-5-2

**Approvals and certificates**

UL approval	cULus Listed, Class 2 Power Source or listed Power Supply with a limited voltage output with (maybe integrated) fuse (max. 3.3 A according UL248), Type 1 enclosure
CCC approval	CCC approval / marking not required for products rated ≤36 V

**Accessories****OMH-F10-ML100**

Mounting aid for ML100 series

**OMH-ML100-01**

Mounting aid for ML100 series, mounting bracket

**OMH-ML100-02**

Mounting aid for ML100 series, mounting bracket

**OMH-ML100-03**

Mounting aid for round steel ø 12 mm or sheet 1.5 mm ... 3 mm

**OMH-ML100-04**

Mounting aid for ML100 series, mounting bracket

**OMH-ML100-05**

Mounting aid for ML100 series, mounting bracket

**OMH-10**

Mounting aid

**REF-H85-2**

Reflector, rectangular 84.5 mm x 84.5 mm, mounting holes

**REF-C110-2**

Reflector, round ø 84 mm, central mounting hole

**REF-H60-2**

Reflector with mounting holes

**REF-H50**

Reflector, rectangular 51 mm x 61 mm, mounting holes, fixing strap

**REF-H33**

Reflector with screw fixing

**OFR-70-2**

Reflective tape 70 mm x 70 mm

**OMH-ML100-08**

Mounting aid for ML100 series, Snap-in

Other suitable accessories can be found at [www.pepperl-fuchs.com](http://www.pepperl-fuchs.com)

## Curves/Diagrams

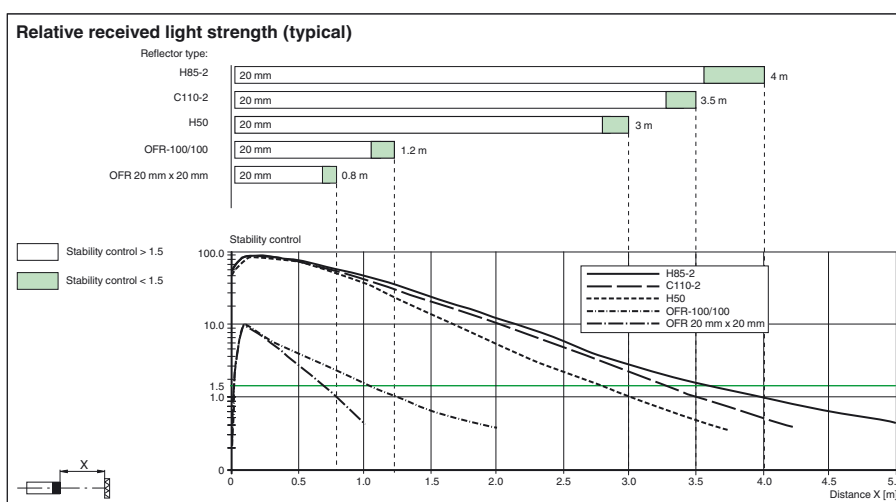
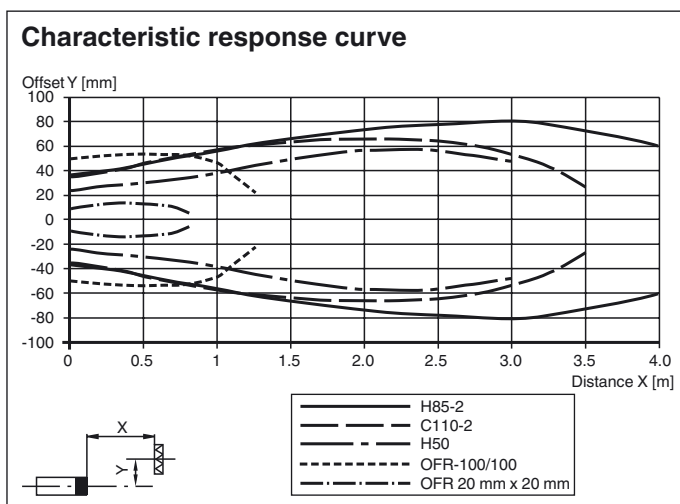

## System Description

The retro-reflective sensor contains both an emitter and a receiver in a single housing. A reflector reflects the light from emitter back to the receiver. If an object interrupts the light beam, the switching function is initiated.

## Mounting

The sensors can be mounted directly via through-holes or by using a mounting bracket or a clamp component. Mounting brackets and clamp components are available as accessories.

Ensure that the surface is flat to avoid housing distortion during mounting and fixing.

Secure nut and bolt with spring washers to prevent misalignment of the sensor.

**Adjusting the Sensor:** Apply the operating voltage to the sensor. The power indicator lights green.

Mount a suitable reflector opposite the retroreflective sensor. Align the sensor (without object) roughly with the reflector. Then adjust the sensor to the reflector by tilting it horizontally and vertically until the yellow signal indicator is permanently lights up. If the alignment is inaccurate, the yellow signal indicator flashes.

## Commissioning

**Check Object Detection:** Check as follows if the sensor detects objects as intended.

Position the object in the beam path of the sensor.

Once the object is detected, the yellow signal indicator goes out. As soon as the object leaves the beam path of the sensor, the yellow signal indicator permanently lights up again.

## Maintenance

**Cleaning:** If reception deteriorates, e. g. due to dirt, the yellow signal indicator of the receiver flashes. Clean the optical interfaces of the sensor (e. g. lenses) at regular intervals.

**Servicing:** Check the mounting screw connections and the electrical plug connections regularly.