

Dimensions

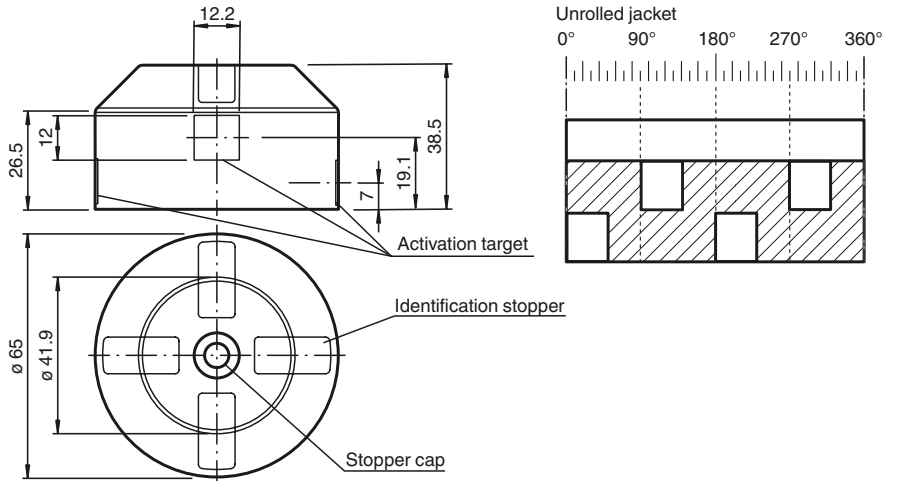

Model Number

BT65U

Activator for F31 series

Features

- 4 fixed actuating lugs for redundant construction of 2 double sensors at rotational motion of 90°
- Additionally loose actuating lugs for individual fixing
- Suitable for right and left rotating drives

Technical data

General specifications

Ring diameter	≤ 65 mm
Spring ring height	≤ 6 mm

Ambient conditions

Ambient temperature	-25 ... 70 °C (-13 ... 158 °F)
---------------------	--------------------------------

Mechanical specifications

Shaft diameter	< 58 mm
Shaft height	20 mm and 30 mm
Mounting hole pattern	30 x 80 mm

Material

Housing	Mounting component: PA
Spacer disk	PA (1 unit, 10 mm strong)
Stopper cap	PE (1 unit black)
Identification stopper	PA (3 pcs. yellow, 3 pcs. black)
Mounting screw	for activator: 1.4305 / AISI 303 (V2A) (1 piece M6 x 25), (1 piece M6 x 16) for sensors - F31: 1.4305 / AISI 303 (4 pieces M5 x 16) (2 pieces M5 x 12)

Activation target	Stainless steel 1.4305 / AISI 303 (integrated)
-------------------	--

Mass	40 g
------	------

Note

The activator consists of a conductive plastic material which prevents static charging and allows installation in potentially explosive environments.

Release date: 2018-12-17 13:58 Date of issue: 2018-12-17 319898_eng.xml