



**Model Number**

**DoorScan-I**

Sensor module, interface

**Features**

- Sensor module for configurable DoorScan® presence sensor
- Multi-function interface with full operation
- Complete system supply for the entire system for one door
- Can also be used to supply the emitter and receiver modules with power
- Single button commissioning with automatic Teach-in function
- SIL 2, certified in accordance with DIN 18650/EN 16005
- Tool-free module mounting using snap-in mechanism
- Switchable NPN or PNP outputs

**Dimensions**

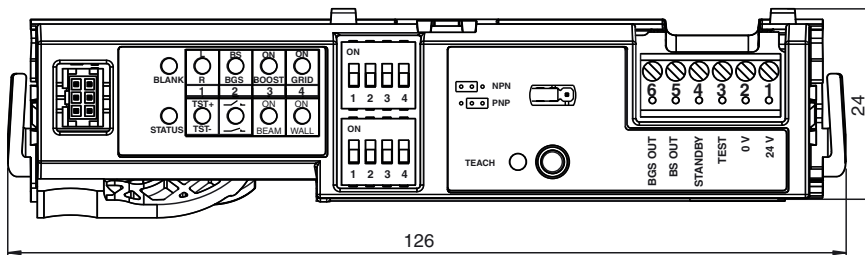

**Electrical connection**

1	BN	— 24V
2	BU	— 0V
3	GY	— TEST
4	PK	— STANDBY
5	BK	— BS OUT
6	WH	— BGS OUT

**Indicators/operating means**

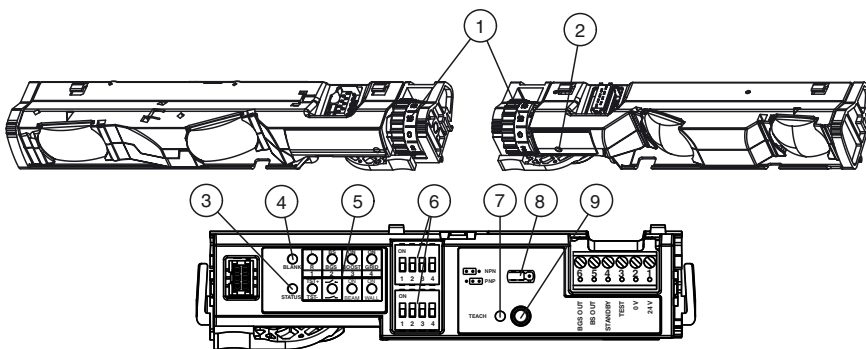

- |   |                             |
|---|-----------------------------|
| 1 Adjusting wheel for inclination angle | 6 DIP switch - rows 1 and 2 |
| 2 Receiver indicator LED, red           | 7 Teach LED, yellow         |
| 3 Status LED, red                       | 8 Jumper                    |
| 4 Blank LED, green                      | 9 Teach button              |
| 5 DIP LEDs, green                       |                             |

Release date: 2019-08-26 14:31 Date of issue: 2019-08-26 299669\_eng.xml

**Technical data**

**General specifications**

Operating mode Background evaluation

**Functional safety related parameters**

Safety Integrity Level (SIL) SIL 2  
 Performance level (PL) PL d  
 Category Cat. 2  
 MTTF<sub>d</sub> 2716 a  
 Mission Time (T<sub>M</sub>) 20 a  
 Diagnostic Coverage (DC) 90 %

**Indicators/operating means**

Function indicator Interface: Red LED: detection, excess gain, fault code  
 Yellow LED: teach status  
 Green LED: blank status  
 Green LED: DIP switch status

**Electrical specifications**

Operating voltage U<sub>B</sub> 24 V DC +/- 20 %  
 No-load supply current I<sub>0</sub> 30 mA

**Input**

Test input high level ≥ 15 V low level ≤ 2 V  
 Control input Standby active at U = 11 V DC at 30 V DC

**Output**

Switching type light on  
 Signal output switchable NPN or PNP , short-circuit protected  
 Switching voltage max. 30 V DC  
 Switching current max. 100 mA  
 Response time ≤ 52 ms  
 ≤ 200 ms in boost operating mode

**Conformity**

Functional safety ISO 13849-1 ; EN 61508 part1-4  
 Product standard EN 12978

**Ambient conditions**

Ambient temperature -30 ... 60 °C (-22 ... 140 °F)

**Mechanical specifications**

Mounting height max. 3500 mm  
 Degree of protection IP54 (iwhen mounted)  
 Connection plug strip , 6-pin  
 Mass approx. 30 g

**Approvals and certificates**

CCC approval CCC approval / marking not required for products rated ≤36 V

**Additional Information**

**Layout of the sensor system for a door (door hinge side/hinge opposite side)**

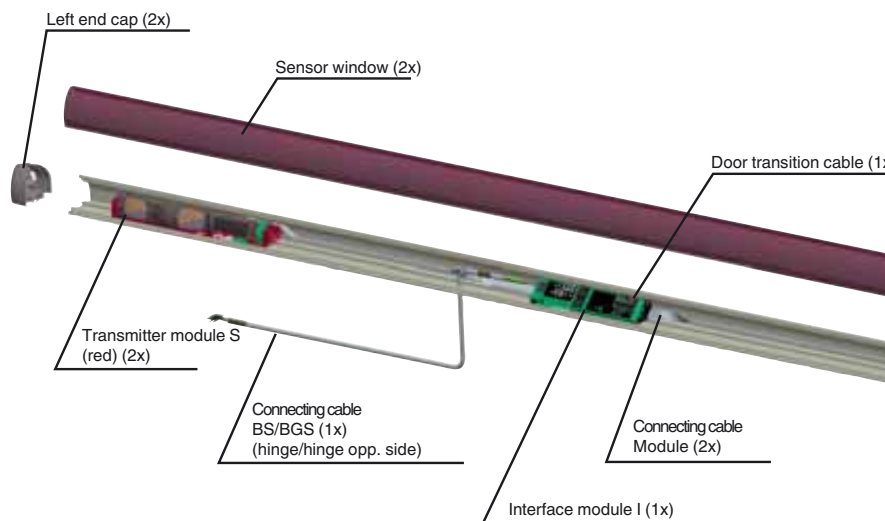

**Standby**

When the supply voltage is applied, the sensor is put into standby; the energy consumption is reduced to less than 80% in this state. Once the signal is deactivated, the sensor is immediately ready for operation and enables the signal outputs within 52 ms and/or 200 ms (in

**Accessories**

**DoorScan Cable BS/BGS**

Connecting cable for transition from hinge side to leading edge side

**DoorScan Transfer Loop**

Door transition cable to door controller for DoorScan® sensor, including cable sheathing and strain relief

**DoorScan Connection Cable 5p**

Connecting cable with 5 plug-in connections for DoorScan®-I/-T/-R modules

**DoorScan Adapter**

Adapter module for installation in the DoorScan® and TopScan sensor profile, multifunction interface module

**DoorScan Cable Adapter**

Adapter module for installation in the DoorScan® sensor profile, multifunction interface module

Other suitable accessories can be found at [www.pepperl-fuchs.com](http://www.pepperl-fuchs.com)

Release date: 2019-08-26 14:31 Date of issue: 2019-08-26 299669\_eng.xml

boost operating mode) if the detection field is free.

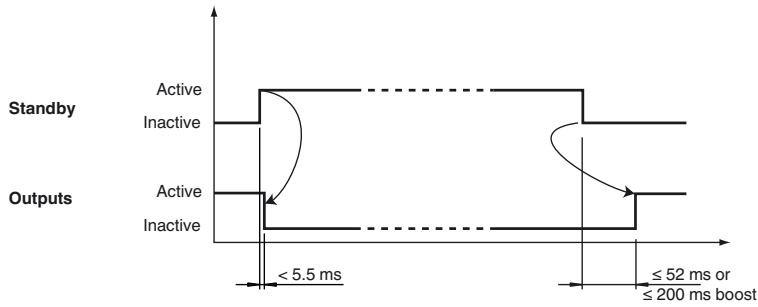

**Test input circuit**

DoorScan test input circuit

Test Function	Test inactive	Test active	Interface, bottom row, Dip switch 1 and 2
High active			
Low active			
High inactive			
Low inactive			

**Test signal**

The signal outputs enable crossed circuit detection. To do so, the outputs carry out a delayed shutoff from each other (see signal curve).

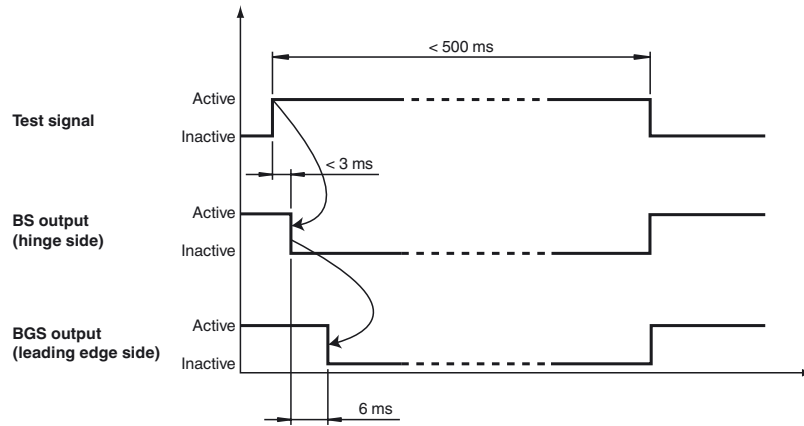

**Note!**

The test signal must be in contact with the test input for at least 9 ms!  
The duration of the test signal must not exceed 0.5 s, otherwise this will deactivate the sensor.

**Operating modes**

**Boost operating mode**

Activation with dark floors, even at high installation heights (increased sensitivity). In these cases, the response time of the sensor is increased from 50 ms to 200 ms. If necessary, the speed of the door must be adjusted to the response time.

**Grid operating mode**

Activation in the event of faults due to metal grating on the ground. Used where metal grating and shafts are present in the detection field.

**BEAM**

Off: outer beams normal

On: outer beams at an angle (factory setting)

You can switch off the beams extending beyond the emitter modules manually to avoid detection of deep door jambs.

Release date: 2019-08-26 14:31 Date of issue: 2019-08-26 299669\_eng.xml

WALL

Off: automatic wall suppression not active

On: automatic wall suppression active (factory setting)

If the door panel does not open against a wall, you can switch off wall suppression to accelerate the commissioning process. Metal grating mode is improved if receiver modules are used from device version V.03 onward.