



Model Number

OBE500-R2F-SE0-Y253561

Thru-beam sensor (pair)
with 2 m fixed cable

Features

- Very flat design for direct mounting without mounting bracket
- TEACH-IN
- Detection of partially transparent objects by teach-in
- Very bright, highly visible light spot

Dimensions

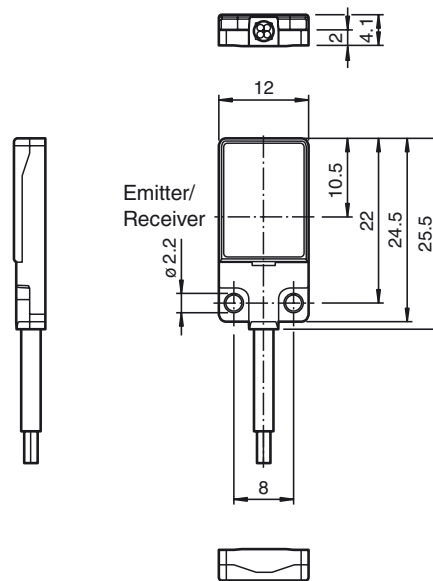

Electrical connection

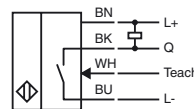
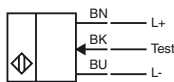

Release date: 2019-10-29 09:54 Date of issue: 2019-10-29 253561_eng.xml

Refer to "General Notes Relating to Pepperl+Fuchs Product Information".

Technical data**System components**

Emitter	OBE500-R2F-S
Receiver	OBE500-R2F-E0-Y813034

General specifications

Effective detection range	0 ... 500 mm
---------------------------	--------------

Threshold detection range	700 mm
---------------------------	--------

Light source	LED
--------------	-----

Light type	modulated visible red light , 630 nm
------------	--------------------------------------

LED risk group labelling	exempt group
--------------------------	--------------

Angle deviation	approx. 2 °
-----------------	-------------

Object size	typ. starts from 1.5 mm
-------------	-------------------------

Diameter of the light spot	approx. 90 mm at a distance of 500 mm
----------------------------	---------------------------------------

Angle of divergence	approx. 5 °
---------------------	-------------

Optical face	frontal
--------------	---------

Ambient light limit	EN 60947-5-2 : 25000 Lux
---------------------	--------------------------

Functional safety related parameters

MTTF _d	806 a
-------------------	-------

Mission Time (T _M)	20 a
--------------------------------	------

Diagnostic Coverage (DC)	0 %
--------------------------	-----

Indicators/operating means

Operation indicator	LED green, statically lit Power on , short-circuit : LED green flashing (approx. 4 Hz)
---------------------	--

Function indicator	Receiver: LED yellow, lights up when light beam is free, flashes when falling short of the stability control ; OFF when light beam is interrupted
--------------------	---

Electrical specifications

Operating voltage	U _B	10 ... 30 V DC
-------------------	----------------	----------------

No-load supply current	I ₀	< 10 mA
------------------------	----------------	---------

Protection class	III
------------------	-----

Input

Test input	Test of switching function at 0 V
------------	-----------------------------------

Switching threshold	Teach-In input
---------------------	----------------

Output

Switching type	NO contact / dark on
----------------	----------------------

Signal output	1 NPN output, short-circuit protected, reverse polarity protected, open collector
---------------	---

Switching voltage	max. 30 V DC
-------------------	--------------

Switching current	max. 50 mA , resistive load
-------------------	-----------------------------

Voltage drop	U _d	≤ 1.5 V DC
--------------	----------------	------------

Switching frequency	f	approx. 1 kHz
---------------------	---	---------------

Response time	500 μs
---------------	--------

Conformity

Product standard	EN 60947-5-2
------------------	--------------

Ambient conditions

Ambient temperature	-20 ... 60 °C (-4 ... 140 °F)
---------------------	-------------------------------

Storage temperature	-20 ... 70 °C (-4 ... 158 °F)
---------------------	-------------------------------

Mechanical specifications

Housing width	12 mm
---------------	-------

Housing height	25.5 mm
----------------	---------

Housing depth	4.1 mm
---------------	--------

Degree of protection	IP67
----------------------	------

Connection	2 m fixed cable
------------	-----------------

Material

Housing	PC (Polycarbonate) and Stainless steel
---------	--

Optical face	PMMA
--------------	------

Cable	PUR
-------	-----

Mass	approx. 20 g Per sensor
------	-------------------------

Tightening torque, fastening screws	0.25 Nm
-------------------------------------	---------

Cable length	2 m
--------------	-----

Approvals and certificates

UL approval	E87056 , cULus Recognized, Class 2 Power Source
-------------	---

CCC approval	CCC approval / marking not required for products rated ≤36 V
--------------	--

Other suitable accessories can be found at
www.pepperl-fuchs.com

Curves/Diagrams

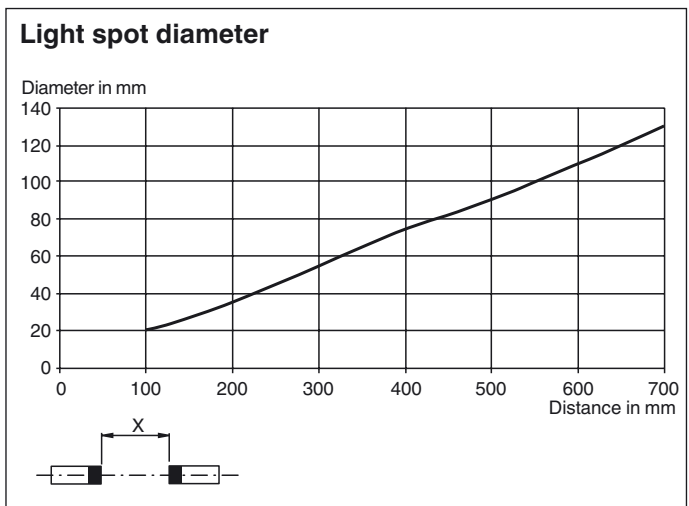
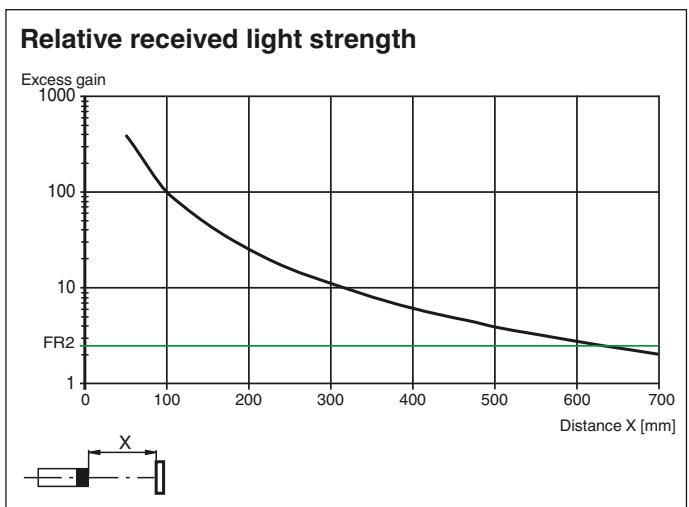
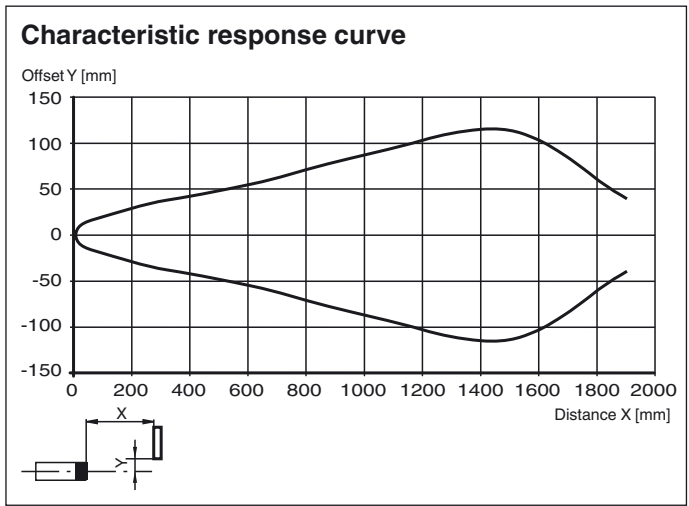

Teach-In Methods

The thru-beam sensor enables the switching points to be taught in for optimum adaptation to specific applications. This eliminates the need for additional components such as apertures.

The sensitivity of the thru-beam sensor can be adjusted using three Teach-in methods:

Position Teach

When using this Teach-in method, the following settings are made on the thru-beam sensor:

- The gain is set to an optimum value
- The signal threshold is set to a minimum

Release date: 2019-10-29 09:54 Date of issue: 2019-10-29 253561_eng.xml

Refer to "General Notes Relating to Pepperl+Fuchs Product Information".

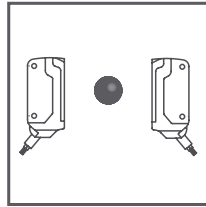
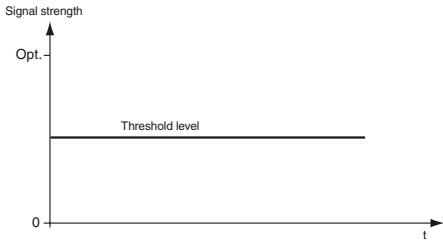

Recommended application:

This method enables minuscule particles in the beam path to be detected, and provides exceptional positioning accuracy. Make sure that there are no objects in the beam path and that the sensor is connected to the power supply.

1. Connect the white cable on the receiver (WH/IN) to the blue cable (BU/0 V) on the receiver. The green and yellow LED indicators flash simultaneously at 2.5 Hz
2. Disconnect the white cable on the receiver (WH/IN) from the blue cable (BU/0 V) on the receiver. The green and yellow LED indicators flash alternately at 2.5 Hz
3. The end of the Teach-in process is indicated when the green LED indicator lights up static and yellow LED blinks.

Two-Point Teach-In

When using this Teach-in method, the following settings are made on the thru-beam sensor:

- The gain is set to an optimum value
- The signal threshold is set in the center between the two taught signal values

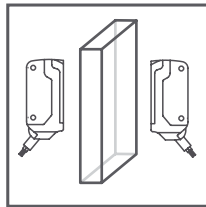
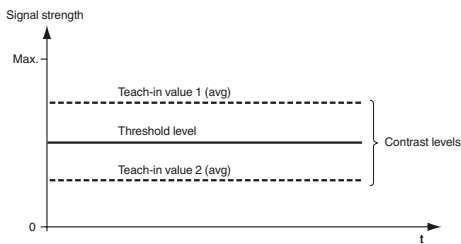

1. Make sure that there are no objects in the beam path and that the sensor is connected to the power supply.
2. Connect the white cable on the receiver (WH/IN) to the blue cable (BU/0 V) on the receiver. The green and yellow LED indicators flash simultaneously at 2.5 Hz
3. Position the object in the beam path.
4. Disconnect the white cable on the receiver (WH/IN) from the blue cable (BU/0 V) on the receiver. The green and yellow LED indicators flash alternately at 2.5 Hz
5. The end of the Teach-in process is indicated when the green LED indicator lights up static.

Maximum Teach-In

When using this Teach-in method, the following settings are made on the thru-beam sensor:

- The gain is set to a maximum
- The signal threshold is set to a minimum

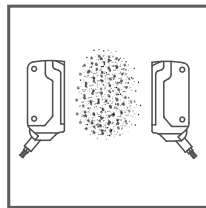
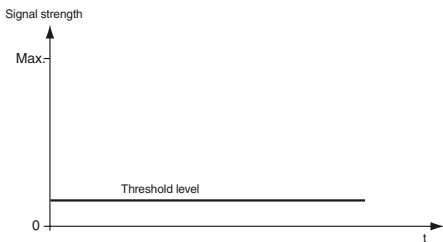

Recommended application:

Enables an object to be detected with a high excess gain. This can be useful if there is severe environmental contamination or to achieve long operating times.

Make sure that there are no objects in the beam path and that the sensor is connected to the power supply.

6. Cover the receiver or transmitter.
7. Connect the white cable on the receiver (WH/IN) to the blue cable (BU/0 V) on the receiver. The green and yellow LED indicators flash simultaneously at 2.5 Hz
8. Disconnect the white cable on the receiver (WH/IN) from the blue cable (BU/0 V) on the receiver. The green and yellow LED indicators flash alternately at 2.5 Hz
9. The end of the Teach-in process is indicated when the green LED indicator lights up static.

Release date: 2019-10-29 09:54 Date of issue: 2019-10-29 253561_eng.xml