



Model Number

NCN3-F31-B3-V1-K

Valve positioner and valve control module

Features

- Direct mounting on standard actuators
- Mode of operation, programmable
- Lead breakage and short-circuit monitoring of the valve
- Degree of protection IP67
- Communication monitoring, turn-off

Accessories

V1-G

Female connector, M12, 4-pin, field attachable

V1-W-2M-PUR

Female cordset, M12, 4-pin, PUR cable

V1-G-2M-PUR

Female cordset, M12, 4-pin, PUR cable

BT65A

Activator for F31 series

BT65X

Activator for F31 series

Technical Data

General specifications

Switching function	Normally open/closed (NO/NC) programmable
Output type	AS-Interface
Rated operating distance	s_n 3 mm
Installation	flush mountable
Assured operating distance	s_a 0 ... 2.43 mm
Reduction factor r_{AI}	0.5
Reduction factor r_{Cu}	0.45
Reduction factor r_{304}	1
Reduction factor r_{St37}	1.2
Slave type	Standard slave
AS-Interface specification	V2.1
Required master specification	\geq V2.1

Nominal ratings

Operating voltage	U_B	26.5 ... 31.9 V via AS-i bus system
Switching frequency	f	0 ... 100 Hz
No-load supply current	I_0	\leq 35 mA

Functional safety related parameters

MTTF _d	842 a
Mission Time (T _M)	20 a
Diagnostic Coverage (DC)	0 %

Indicators/operating means

LED PWR	AS-Interface voltage; LED green
LED IN	switching state (input); LED yellow
LED OUT	binary LED yellow/red yellow: switching state red: lead breakage/short-circuit

Electrical specifications

Rated operating voltage	U_e	26.5 ... 31.6 V from AS-Interface
Rated operating current	I_e	100 mA

Programming instructions

Parameter bits (programmable via AS-i)

Ambient conditions

Ambient temperature	-25 ... 70 °C (-13 ... 158 °F)
---------------------	--------------------------------

Mechanical specifications

Connection (system side)	4-pin, M12 x 1 connector
Connection (valve side)	0.5 m, PVC cable
Core cross-section (valve side)	0.75 mm ²
Connector housing	metal
Housing material	PBT
Degree of protection	IP67
Cable	
Cable diameter	6 mm \pm 0.2 mm
Bending radius	> 10 x cable diameter
Note	valve voltage limited to 26,4 V max.; valve power 2,5 W max.

Compliance with standards and directives

Standard conformity	
Electromagnetic compatibility	EN 50295:1999-10
Standards	EN 60947-5-2:2007 EN 60947-5-2/A1:2012 IEC 60947-5-2:2007 IEC 60947-5-2 AMD 1:2012

Approvals and certificates

UL approval	cULus Listed, General Purpose
CSA approval	cCSAus Listed, General Purpose
CCC approval	CCC approval / marking not required for products rated \leq 36 V

Dimensions

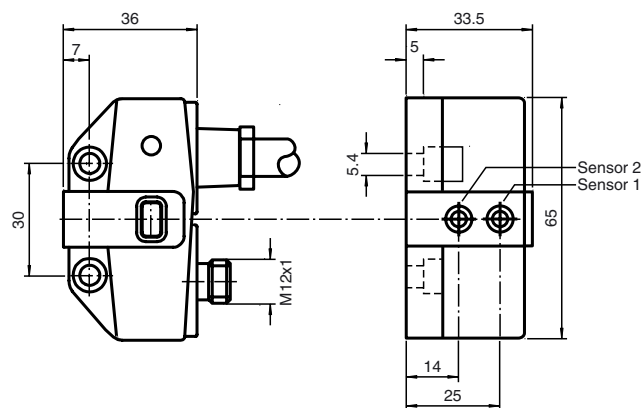

Drawing without actuator

Electrical Connection

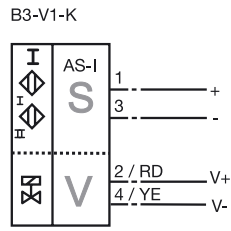

Pinout

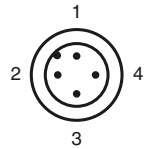

Additional Information

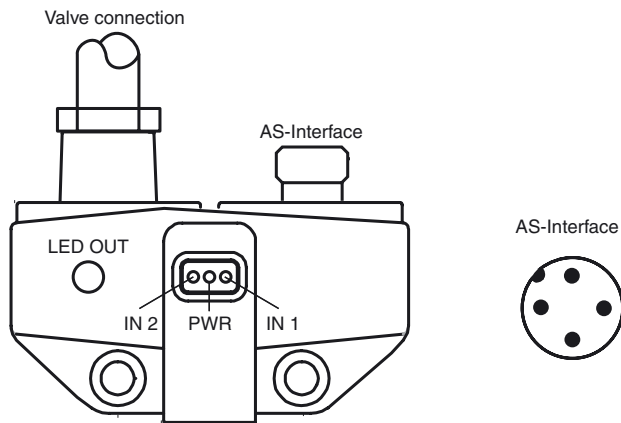

Programming Instructions

Address 00 preset, alterable
via Busmaster or
programming units
IO-code D
ID-code F

Data bit

Bit	function
D0	valve status (0=valve OFF; 1=valve ON)
D1	valve fault ¹⁾ (0=lead breakage/short circuit; 1=no fault)
D2	switch output sensor 1 ²⁾ (0=damped; 1=undamped)
D3	switch output sensor 2 ²⁾ (0=damped; 1=undamped)

Parameter bit

Bit	function
P0	Watchdog (0=inactive; 1=active) ³⁾
P1	not used
P2	switching element function sensor I (0=NO; 1=NC)
P3	switching element function sensor II ⁴⁾ (0=NO; 1=NC)

- 1) Verification only with actuated valve (D0=1)
- 2) Applies to NC function (P2/P3=1; preset),
with NO function (P2/P3=0) reversed characteristics
- 3) Watchdog active: valve voltage drops
with the occurrence of an AS-i communication fault
- 4) Default setting: NC

Installation Hint

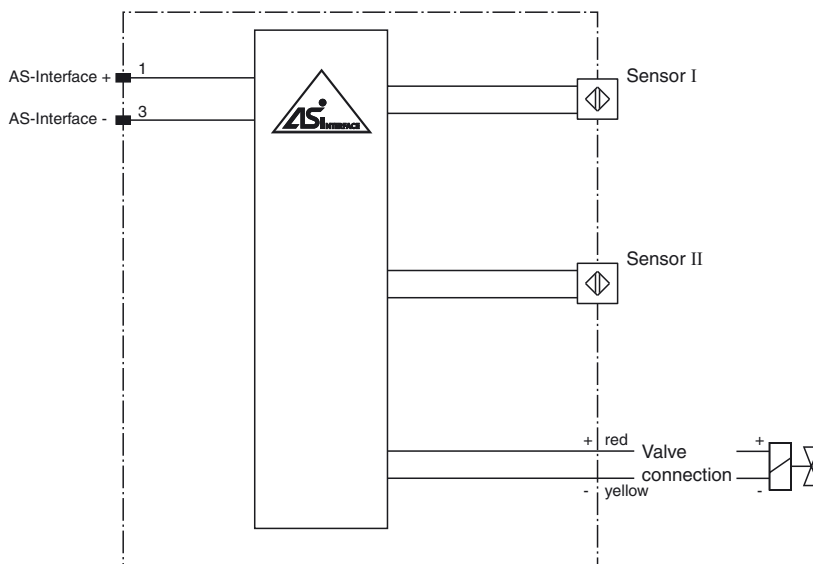

The NCN3-F31-B3-V1-K is an inductive dual sensor used to indicate the valve positioning of actuators. The dual sensor is mounted directly on the actuator using two screws. No additional adjustment is required.

A cable connection on the sensor is used directly for the valve controls. The NCN3-F31-B3-V1-K is connected via a M12x1 screw fixing to the bus line. This makes it possible to transmit both the switch signal for the valve and the messages of the sensor via AS-Interface. They are both powered directly through the bus cable. Moreover, the valve is monitored for lead breakage and short circuit. The D1 data bit monitors the fault signal.

The sensors can be programmed as normally closed and normally open contacts (parameter bit P2 and P3). If there are no communications on the bus cable, the valve is automatically de-energised. The P0 parameter bit disables the watchdog function.

The current switching states are displayed by means of yellow LEDs.