



## Model Number

**NBN3-F31K2M-Z8L-B13-S**

## Features

- Direct mounting on standard actuators
- Compatible with all process control systems
- Weatherproof housing for outdoor applications
- Rugged metal base
- Temperature range -40 ... 167 °F (-40°C to 75°C)
- 2-wire DC sensor with minimum off-state current
- LEDs for switching state of sensor and solenoid valve
- Plug-in terminals

## Application

### Note

The connections to this sensor are sealed with stopping plugs to protect against dirt and moisture. If not all of the connections are used in your application, then seal the remaining stopping plugs on the sensor permanently or check during initial installation and when performing regular maintenance work that the stopping plugs are secure and impermeable. If necessary, tighten the stopping plugs to a torque of 1 Nm.

## Accessories

### BT65-F31K2-RG-EN

Activator for F31K2 series

### BT65A

Activator for F31 series

### BT65X

Activator for F31 series

## Technical Data

### General specifications

Switching function		2 x normally open (NO)
Output type		Two-wire
Rated operating distance	$s_n$	2.5 mm
Installation		for non-flush mounting
Output polarity		DC
Assured operating distance	$s_a$	0 ... 2.05 mm
Output type		2x 2-wire

### Nominal ratings

Operating voltage	$U_B$	6 ... 30 V
Switching frequency	$f$	0 ... 100 Hz
Hysteresis	$H$	typ. 0.5 mm
Reverse polarity protection		reverse polarity tolerant
Short-circuit protection		no
Voltage drop	$U_d$	$\leq 6$ V
Operating current	$I_L$	4 ... 100 mA
Off-state current	$I_r$	100 ... 200 $\mu$ A typ. 160 $\mu$ A
Switching state indicator		LED, yellow
Valve status indicator		LED, yellow

### Functional safety related parameters

MTTF <sub>d</sub>	684 a
Mission Time (T <sub>M</sub> )	20 a
Diagnostic Coverage (DC)	0 %

### Valve circuit

Voltage	max. 32 V DC
Current	max. 240 mA
Short-circuit protection	no
Reverse polarity protection	yes, with reversed output LED is out of function, therefore more power for solenoid valve

### Ambient conditions

Ambient temperature	-40 ... 75 °C (-40 ... 167 °F) , restriction for use in hazardous area, see instruction manual
Storage temperature	-40 ... 85 °C (-40 ... 185 °F)

### Mechanical specifications

Connection (system side)	screw terminal , M20 x 1.5 cable gland
Core cross-section (system side)	1.5/2.5 mm <sup>2</sup> flexible/rigid
Connection (valve side)	screw terminal , Cable gland M20 x 1.5
Housing material	rugged, translucent polycarbonate (PC) optimised for outdoor use
Housing base	powder coated aluminum
Degree of protection	IP66 / IP68 / IP69
Tightening torque, housing screws	$\leq 2$ Nm
Tightening torque, cable gland	M20 x 1.5 ; $\leq 11$ Nm
Tightening torque, stopping plug	1 Nm

### Compliance with standards and directives

Standard conformity	
Standards	EN 60947-5-2:2007 EN 60947-5-2/A1:2012 IEC 60947-5-2:2007 IEC 60947-5-2 AMD 1:2012 VDI / VDE 3845

### Approvals and certificates

EAC conformity	TR CU 020/2011
UL approval	cULus Listed, General Purpose, Class 2 Power Source

## Dimensions

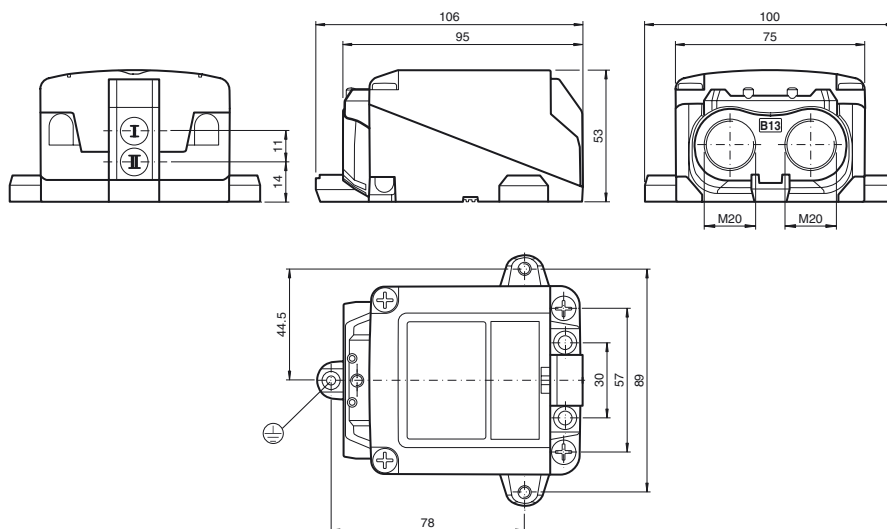

Electrical Connection

