



Model number

INY030D-F99-2U-5M

Features

- E1-Type approval
- Measuring range $-15^{\circ} \dots +15^{\circ}$
- Fixed evaluation limits
- High shock resistance
- Increased noise immunity 100 V/m
- Analog output 0 ... 10 V

Electrical connection

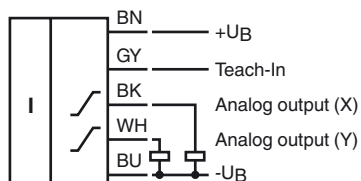

Technical Data

General specifications

Type	Inclination sensor, 2-axis
Measurement range	$-15 \dots 15^{\circ}$
Absolute accuracy	$\leq \pm 0.2^{\circ}$
Response delay	≤ 25 ms
Resolution	$\leq 0.01^{\circ}$
Repeat accuracy	$\leq \pm 0.02^{\circ}$
Temperature influence	$\leq 0.004^{\circ}/K$

Functional safety related parameters

MTTF _d	390 a
Mission Time (T _M)	20 a
Diagnostic Coverage (DC)	0 %

Indicators/operating means

Operation indicator	LED, green
Teach-In indicator	LED, yellow

Electrical specifications

Operating voltage U _B	18 ... 30 V DC
No-load supply current I ₀	≤ 25 mA
Time delay before availability t _v	≤ 200 ms

Analog output

Output type	2 voltage outputs 0 ... 10 V (one output for each axis)
Load resistor	≥ 1 k Ω

Ambient conditions

Ambient temperature	$-40 \dots 85^{\circ}C$ ($-40 \dots 185^{\circ}F$)
Storage temperature	$-40 \dots 85^{\circ}C$ ($-40 \dots 185^{\circ}F$)

Mechanical specifications

Connection type	5 m, PUR cable 5 x 0.5 mm ²
Housing material	PA
Degree of protection	IP68 / IP69K
Mass	240 g

Factory settings

Analog output (X)	$-15^{\circ} \dots 15^{\circ}$
Analog output (Y)	$-15^{\circ} \dots 15^{\circ}$

Compliance with standards and directives

Standard conformity	
Shock and impact resistance	100 g according to DIN EN 60068-2-27
Standards	EN 60947-5-2:2007 IEC 60947-5-2:2007

Approvals and certificates

UL approval	cULus Listed, Class 2 Power Source
CCC approval	CCC approval / marking not required for products rated ≤ 36 V
E1 Type approval	10R-04

EMC Properties

Interference immunity in accordance with
DIN ISO 11452-2: 100 V/m
Frequency band 20 MHz up to 2 GHz
Mains-borne interference in accordance with ISO 7637-2:

Pulse	1	2a	2b	3a	3b	4
Severity level	III	III	III	III	III	III
Failure criterion	C	A	C	A	A	C

EN 61000-4-2:	CD: 8 kV / AD: 15 kV
Severity level	IV / IV
EN 61000-4-3:	30 V/m (80...2500 MHz)
Severity level	IV
EN 61000-4-4:	2 kV
Severity level	III
EN 61000-4-6:	10 V (0.01...80 MHz)
Severity level	III
EN 55011:	Klasse A

Dimensions

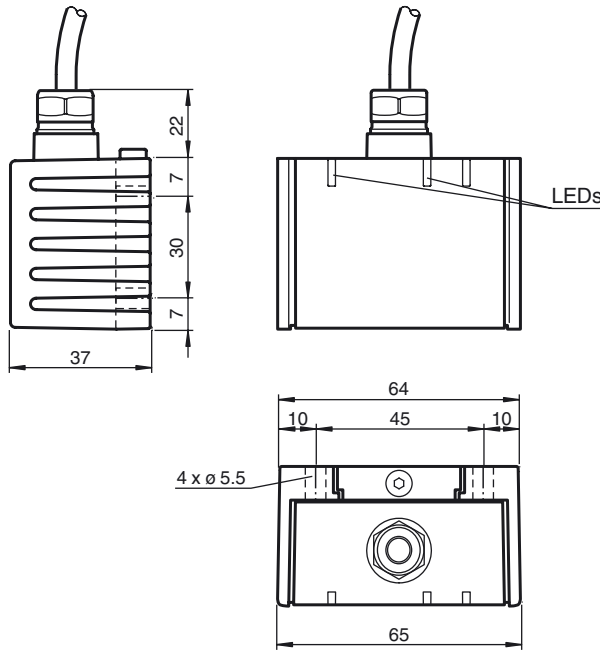

Sensor Orientation

In the default setting the zero position of the sensor is reached, when the sensor is mounted on a horizontal plane and electrical connection faces sideways.

Mounting of the sensor

Sensors from the -F99 series consist of a sensor module and accompanying cast aluminum housing. Select a horizontal flat surface with minimum dimensions of 70 mm x 50 mm to mount the sensor. Mount the sensor as follows:



1. Loosen the central screw under the sensor connection.
 2. Slide back the clamping element until you are able to remove the sensor module from the housing.
 3. Remove the sensor module from the housing
 4. Position the housing at the required mounting location and secure using four countersunk screws. Make sure that the heads of the screws do not protrude.
 5. Place the sensor module in the housing.
 6. Slide the clamping element flush into the housing. Check that the sensor element is seated correctly.
 7. Finally tighten the central screw.
- The sensor is now mounted correctly.

LED display

Displays dependent on the operating state	LED green: Power	LED yellow Teach In
Normal operation	on	off
Teach In of reference point	on	on
Teach In connected to +U _B for 1 s ... 10 s	on	flashes 3 x
falling slope at Teach In input	on	off
then sensor returns to normal operation.	on	off
Reset to factory settings:	on	on
Teach In connected to +U _B for 20 s ... 25 s	on	flashes 3 x
falling slope at Teach In input	on	off
then sensor returns to normal operation.	on	off
Undervoltage	flashes	off

Factory settings

see Technical Data

Release date: 2020-03-20 08:42 Date of edition: 2020-03-20 239184_eng.xml

Axis definition

The definition of the X-axis is shown on the sensor housing by means of an imprinted and labeled double arrow. The figure shows the clockwise direction of rotation.

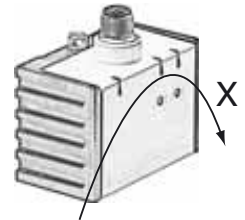
**Teach-in of reference point (output S1)**

1. Move sensor to reference position
2. Apply supply voltage (+Ub) to Teach In input for 1 s ... 10 s
3. Teach In LED lights up for confirmation
4. Disconnect Teach In input (Pin 4) before the 10 s time elapses
5. Teach In LED flashes 3 x for confirmation
6. Reference point is now programmed and the sensor returns to normal operation (see LED display)

Resetting the sensor to factory settings

1. Apply supply voltage (+Ub) to Teach In input for 20 s ... 25 s
2. Teach In LED lights up for confirmation
3. Disconnect Teach In input (Pin 4) before the 25 s time elapses
4. Teach In LED and Out LED flash 3 x for confirmation
5. The sensor is now reseted to factory settings and returns to normal operation (see LED display)

Undervoltage detection

If the supply voltage falls below a value of approx. 7 V, all outputs and yellow LEDs are deactivated. The green "power" LED flashes rapidly. If the supply voltage rises above a value of approx. 8 V, the sensor continues with normal operation.