



**Model Number**

**MLV41-8-H-120-RT-IO/65b/98/103**

Background suppression sensor with 3-pin, M8 x 1 connector

**Features**

- Rugged series in corrosion-resistant metal housing
- MPT Multi Pixel Technology
- IO-link interface for service and process data
- Reliable detection of all surfaces, independent of color and structure
- Precision background suppression, adjustable
- Low sensitivity to target color
- Clear and functional display concept for the operating modes

**Product information**

The diffuse mode sensor with MPT technology combines the benefits of the triangulation principle with the measuring functionality of a distance sensor. The integrated measuring principle provides an extremely wide range of switching element functions in one device, along with a large detection range and a small black/white difference up to the final detection range. The sensor is equipped with an IO-Link interface, through which the measuring principle is optimized to the requirements of the relevant application.

**Dimensions**

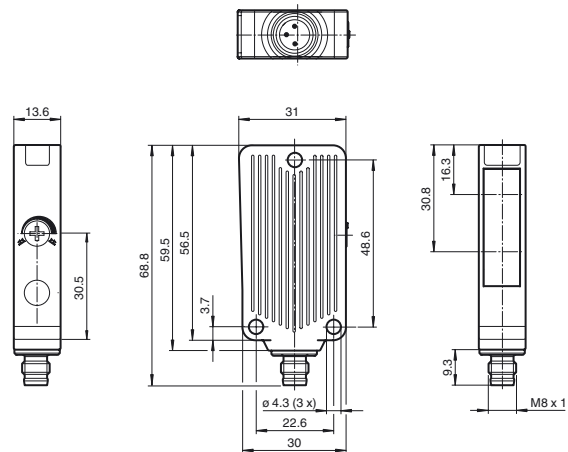

**Electrical connection**

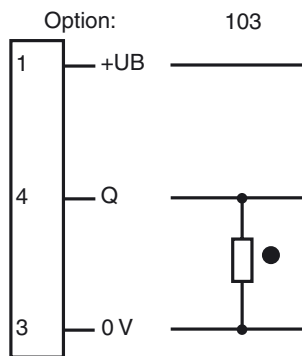

○ = Light on  
● = Dark on

**Pinout**



Wire colors in accordance with EN 60947-5-2

- 1 | BN (brown)
- 3 | BU (blue)
- 4 | BK (black)

**Indicators/operating means**

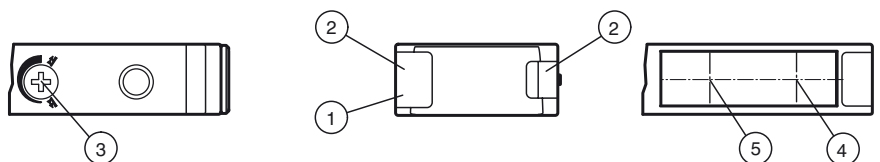

1	Operating display green	3	Sensing range adjuster	5	Optical axis receiver
2	Function display yellow	4	Optical axis transmitter		

Release date: 2019-11-27 14:11 Date of issue: 2019-11-27 222741\_eng.xml

Refer to "General Notes Relating to Pepperl+Fuchs Product Information".

**Technical data****General specifications**

Detection range	20 ... 120 mm Black-white difference < 3%
Adjustment range	20 ... 120 mm
Diagnosis range	20 ... 120 mm
Reference target	standard white, 100 mm x 100 mm
Light source	LED
Light type	modulated visible red light
Diameter of the light spot	approx. 4 mm at sensor range 100 mm
Angle of divergence	approx. 2.5 °
Ambient light limit	25000 Lux

**Functional safety related parameters**

MTTF <sub>d</sub>	500 a
Mission Time (T <sub>M</sub> )	20 a
Diagnostic Coverage (DC)	0 %

**Indicators/operating means**

Operation indicator	LED green, statically lit Power on , Undervoltage indicator: Green LED, pulsing (approx. 0.8 Hz) , short-circuit : LED green flashing (approx. 4 Hz)
Function indicator	2 LEDs yellow ON: object inside the scanning range OFF: object outside the scanning range
Control elements	Sensing range adjuster
Parameterization indicator	IO link communication: green LED goes out briefly (1 Hz)

**Electrical specifications**

Operating voltage	U <sub>B</sub>	10 ... 30 V DC , class 2
Ripple		max. 10 %
No-load supply current	I <sub>0</sub>	max. 25 mA at 24 V supply voltage

**Interface**

Interface type	IO-Link
Protocol	IO-Link V1.0
Mode	COM 2 (38.4 kBaud)

**Output**

Switching type	dark on	
Signal output	1 PNP output, short-circuit protected, reverse polarity protected, open collector	
Switching voltage	max. 30 V DC	
Switching current	max. 100 mA	
Voltage drop	U <sub>d</sub>	≤ 2 V DC
Switching frequency	f	200 Hz
Response time		2.5 ms

**Conformity**

Product standard	EN 60947-5-2
------------------	--------------

**Ambient conditions**

Ambient temperature	-20 ... 60 °C (-4 ... 140 °F) 60 ... 70 °C (140 ... 158 °F) ; max. 20,000 hours = 2.5 years (continuous operation)
Storage temperature	-40 ... 75 °C (-40 ... 167 °F)

**Mechanical specifications**

Housing width	31 mm
Housing height	56.5 mm
Housing depth	13.6 mm
Degree of protection	IP67
Connection	M8 x 1 connector, 3-pin
Material	
Housing	Aluminum , Delta-Seal coated
Optical face	glass pane
Connector	metal
Mass	approx. 40 g

**Approvals and certificates**

UL approval	cULus Listed 57M3 (Only in association with UL Class 2 power supply; Type 1 enclosure)
CCC approval	CCC approval / marking not required for products rated ≤36 V

**Accessories****OMH-09**

Mounting bracket for Sensors series MLV41 for M12 rod mounting

**OMH-40**

Mounting bracket

**OMH-41**

Mounting bracket

**V3-WM-2M-PUR**

Female cordset single-ended, M8, 3-pin, PUR cable

**IO-Link-Master02-USB**

IO-Link master, supply via USB port or separate power supply, LED indicators, M12 plug for sensor connection

**IODD Interpreter DTM**

Software for the integration of IODDs in a frame application (e. g. PACTware)

**MLV41-8 IODD**

IODD for communication with MLV41-8-IO-Link sensors

Other suitable accessories can be found at [www.pepperl-fuchs.com](http://www.pepperl-fuchs.com)

## Curves/Diagrams

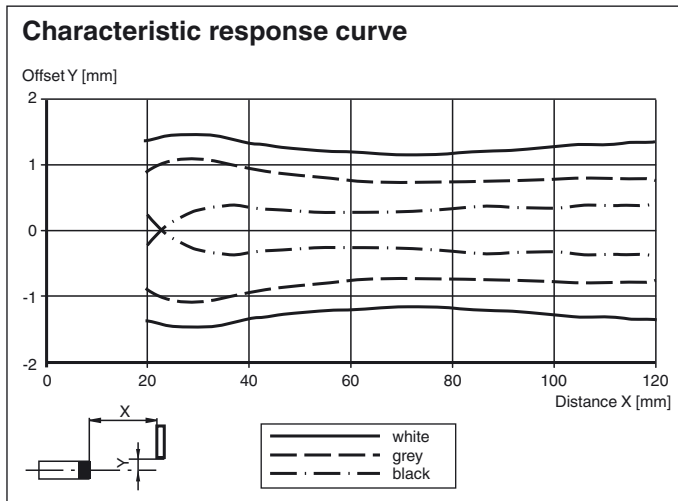

## Setting information

### Detection range adjustment:

The detection range can be set via the rotary switch or the IO-Link.

### Setting using the rotary switch:

If you would like to change the detection range on the sensor, turn:

- the rotary switch to the left to reduce the value.
- the rotary switch to the right to increase the value.

With the IO-Link, the set detection range the current rotary switch configuration is always assigned. If the rotary switch is too far to the left or the right, perform the following:

Increasing the detection range:

Turn the potentiometer completely to the right until it stops. The LED will briefly flash green. The assignment of the current rotary switch configuration to the detection range set via IO-Link is overridden. Now set the desired detection range again.

Reducing the detection range:

Turn the potentiometer completely to the left until it stops. The LED will briefly flash green. The assignment of the current rotary switch configuration to the detection range set via IO-Link is overridden. Now set the desired detection range again.

### Example application - manually reduce detection range:



The potentiometer has one position as shown here. The adjustable detection range is 20 to 120 mm and is set via IO-Link to 100 mm. The rotary switch is too far to the left to set a detection range of 40 mm for example.



Turn the potentiometer to the left until it stops to override the set value to this rotary switch configuration. The LED will briefly flash green.



Now set the desired detection range again between 20 and 120 mm.

## Setting via IO-Link interface

### Setting different operating modes via IO-Link interface

The devices have an IO-Link interface as standard for diagnostic and parameterization tasks enabling optimum adaptation of the sensors to the application. In addition, four different operating modes can be set:

### Background suppression operating mode (1 or 2 switching points):

- Detection of objects irrespective of type and color in a defined sensing range. Objects in the background are reliably suppressed
- Background suppression with 2 switching points

**Background evaluation operating mode:**

- Detection of objects irrespective of type and color against a defined background. Reliable detection of objects at close range (detection range  $\geq 0$  mm). The background serves as reference

**Window operation operating mode:**

- Detection of objects irrespective of type and color in a defined sensing range. Reliable detection when leaving the defined sensing range.

**Hysteresis operating mode:**

- Detection of objects irrespective of type and color between a defined switch-on and switch-off point

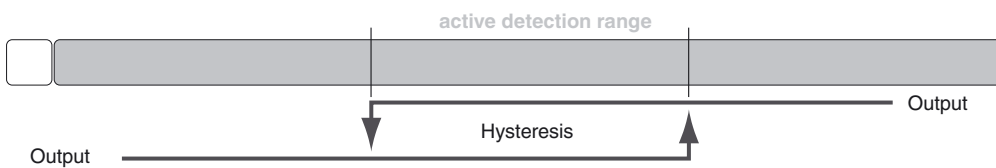

To use the diagnostic and parameterization options, you will find the compatible IODD, and if required, the FDT base application PACTware in the download area at [www.pepperl-fuchs.com](http://www.pepperl-fuchs.com).