

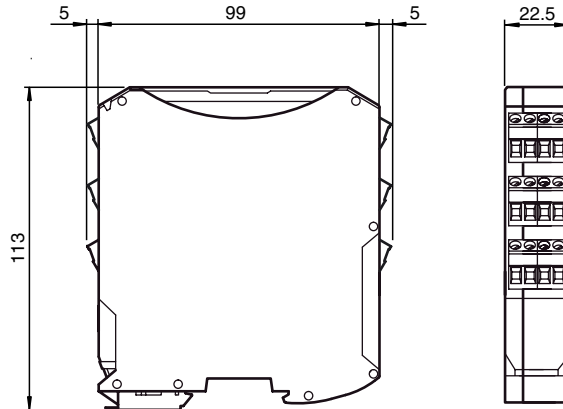

Dimensions

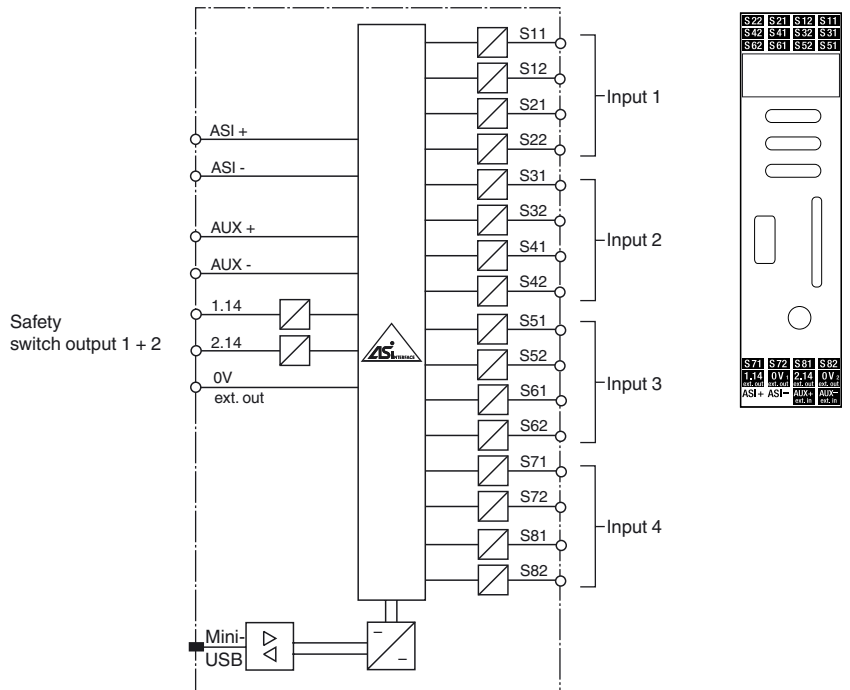

Electrical connection



Model number

VAS-2A8L-KE4-8SE

Safety Monitor, 8 decentralized output circuits

Features

- Compact safety controller up to SIL 3/PLe
- 4 integrated, safe inputs
- 2 integrated, safe outputs (OSSDs)
- 8 logical, safe output groups (switchable)
- Increased functionality through integrated expansion port
- Parameterizable muting, timer and logic functions using SIMON+ software

Indicating / Operating means

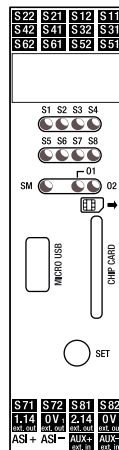

SET = Service button  
CHIP CARD = Chip card

Release date: 2019-11-26 15:07 Date of issue: 2019-11-26 261493\_eng.xml

**Technical data****General specifications**

AS-Interface specification	V3.0
UL File Number	E223772

**Functional safety related parameters**

Safety Integrity Level (SIL)	SIL 3
Performance level (PL)	PL e
Mission Time (T <sub>M</sub> )	20 a
PFH <sub>d</sub>	5.08 E-9

**Indicators/operating means**

LED SM	Status of safety monitor, multicolored LED green: Safety monitor OK
LED S1 ... S8	Status of inputs S1 ... S8, yellow LED yellow: Contact open
LED O1, O2	Status of outputs, multicolored LED yellow: Output on

**Electrical specifications**

Auxiliary voltage (input)	U <sub>EXT</sub>	20 ... 30 V <sub>DC</sub> PELV
Insulation voltage	U <sub>i</sub>	500 V AS-Interface/U <sub>AUX</sub> :
Rated operating voltage	U <sub>e</sub>	18,0 ... 31.6 V from AS-Interface
Rated operating current	I <sub>e</sub>	≤ 200 mA from AS-Interface; ≤ 4 A from AUX

**Interface 1**

Interface type	Chip card slot
----------------	----------------

**Interface 2**

Interface type	Micro USB Programming interface
----------------	------------------------------------

**Input**

Number/Type	8 / 4 safe inputs cat. 4 or 8 standard inputs
Supply	24 V U <sub>AUX</sub>
Current loading capacity	10 mA per signal output 1.4 A OSSD supply output
Input current	Static switching current 4 mA at 24 V, dynamic 30 mA at 24 V (T=100 μs)

**Output**

Number/Type	Output circuits 1 and 2 max. contact rating: 700 m A <sub>DC-13</sub> at 24 V
Supply	24 V U <sub>AUX</sub>

**Directive conformity**

Electromagnetic compatibility	
Directive 2014/30/EU	EN 62026-2:2013 EN 61000-6-2:2005/AC:2005 EN 61000-6-4:2007/A1:2011
Machinery Directive	
Directive 2006/42/EC	EN 13849-1:2008/AC:2009 EN 62061:2005

**Standard conformity**

Electromagnetic compatibility	
	EN 50295:1999 EN 61000-6-2:2005/AC:2005 EN 61000-6-4:2007/A1:2011
Degree of protection	EN 60529:2000
Electrical safety	IEC 61508:2010 and EN 62061:2005 (up to SIL3) EN 13849-1:2008/AC:2009 EN 61326-3-1:2008
AS-Interface	EN 62026-2:2013

**Programming instructions**

Profile	S-0.B.E
IO code	0
ID code	B
ID1 code	F

**Ambient conditions**

Ambient temperature	0 ... 55 °C (32 ... 131 °F)
Storage temperature	-25 ... 85 °C (-13 ... 185 °F)

**Mechanical specifications**

Degree of protection	IP20
Connection	removable terminals rated connection capacity: rigid/flexible (with and without wire-end ferrules): 0.25 mm <sup>2</sup> ... 2.5 mm <sup>2</sup> for multiple-wire connection with two wires of equal cross-section: flexible with twin wire-end ferrules: 0.5 mm <sup>2</sup> ... 1.5 mm <sup>2</sup>
Material	
Housing	PA 66-FR
Mounting	DIN mounting rail

**Function**

The AS-Interface safety monitor compact VAS-2A8L-KE4-8SE- is a control cabinet module with up to 8/4 local safe inputs and up to 8 independent outputs.

The safe inputs can optionally be configured as standard inputs and signalling outputs. Two of the safe inputs are also suitable as inputs for OSSDs, the others only for potential-free contacts. Each safe input can also be configured as two standard inputs. 8 independent AS-Interface release circuits support multiple safe AS-Interface outputs on a single address. In addition, the test pulse outputs can be switched as diagnostic outputs (not control-safe). The safe circuit for the connected consumers is created using two safety relays.

The housing, which is only 22.5 mm wide, requires little space in the switch cabinet. The module is mounted by clicking it onto the 35 mm mouting rail, compliant with EN 50022.

The AS-Interface and external power supply are each connected by means of a 2-station terminal block. Connection of the inputs and outputs is by means of multiple 4-station terminal blocks. This permits the simple removal of the supply during commissioning or servicing. The supply to the connected slaves is fed either internally via the module from the AS-interface or via an external supply. The current status of the inputs and outputs is indicated via yellow LEDs. Communication faults are indicated via red LEDs. The display of the operating voltage and the address 0 is provided by a green LED.

A Micro-USB interface is used for configuration with the AS-i-Control Tools via ASIMON. The configuration can be transferred to a replacement device using a chip card.

**Accessories****VAZ-SW-SIMON+**

Software for configuration of K30 Master Monitors/K31 and KE4 Safety Monitors

**VAZ-SIMON-USB**

USB Type A to Micro-USB connector