



**Model Number**

NCB50-FP-A2-P4

**Features**

- 50 mm flush
- 4-wire DC
- Surface mount

**Connection**

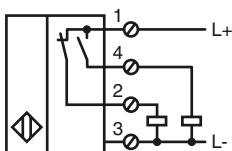

**Dimensions**

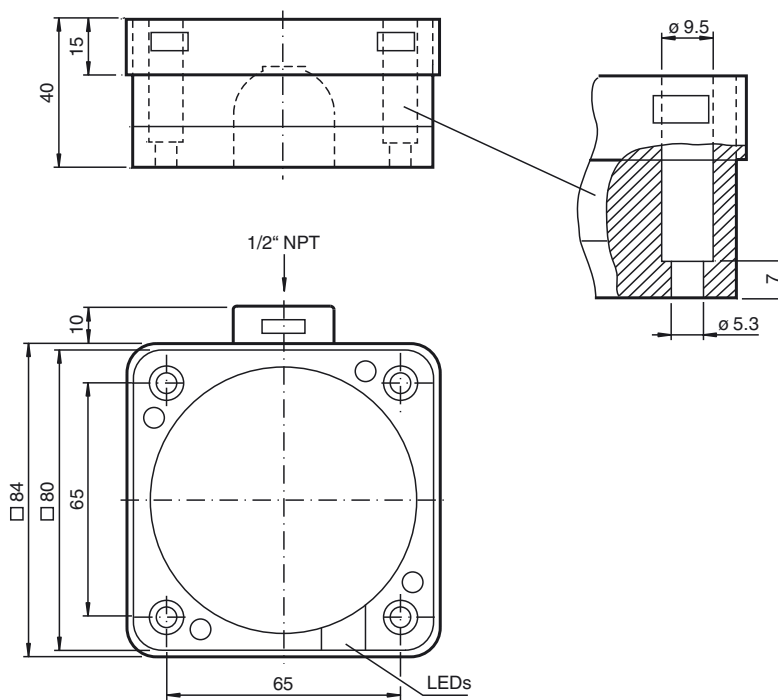

**Technical Data**

General specifications			
Switching element function		PNP	NO/NC
Rated operating distance	$s_n$	50 mm	
Installation		flush	
Output polarity		DC	
Assured operating distance	$s_a$	0 ... 40.5 mm	
Reduction factor $r_{Al}$		0.38	
Reduction factor $r_{Cu}$		0.35	
Reduction factor $r_{304}$		0.83	
Nominal ratings			
Operating voltage	$U_B$	10 ... 60 V DC	
Switching frequency	$f$	0 ... 80 Hz	
Hysteresis	$H$	typ. 3 %	
Reverse polarity protection		reverse polarity protected	
Short-circuit protection		pulsing	
Voltage drop	$U_d$	$\leq 3$ V	
Operating current	$I_L$	0 ... 200 mA	
Off-state current	$I_r$	0 ... 0.5 mA	
No-load supply current	$I_0$	$\leq 20$ mA	
Time delay before availability	$t_v$	$\leq 300$ ms	
Operating voltage display		LED, green	
Switching state indication		LED, yellow	
Functional safety related parameters			
MTTF <sub>d</sub>		680 a	
Mission Time (T <sub>M</sub> )		20 a	
Diagnostic Coverage (DC)		0 %	
Standard conformity			
Standards		EN 60947-5-2:2007 IEC 60947-5-2:2007	
Ambient conditions			
Ambient temperature		-25 ... 70 °C (-13 ... 158 °F)	
Mechanical specifications			
Connection type		screw terminals	
Core cross-section		up to 2.5 mm <sup>2</sup>	
Housing material		PBT/metal	
Sensing face		PBT	
Housing base		metal	
Protection degree		IP68	
Approvals and certificates			
UL approval		cULus Listed, General Purpose	
CSA approval		cCSAus Listed, General Purpose	
CCC approval		Certified by China Compulsory Certification (CCC)	

Release date: 2013-04-17 16:14 Date of issue: 2013-04-17 910960\_eng.xml

**Installation hint**

These sensors are especially designed for embeddable mounting in conveyor floors. Due to its precise location in metal base plates the sensor is afforded a high degree of mechanical protection. No clearance is required between the sensor and the base plate, avoiding the need for protective guarding to prevent possible foot injury.

The large sensing range ensures positive detection, and thus provides consistent control and monitoring of the conveyor.

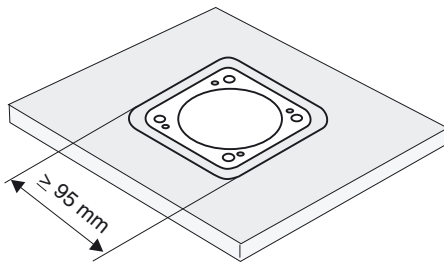

**Warning!**  
Once the metal screening has been removed, the sensor can no longer be embeddable mounted.