



Model Number

MBT-36ALS120

Spring arm for larger spring deflections for diameter 58 rotary encoder with clamping flange

Function

The very high-quality spring arm in combination with a rotary encoder and a measuring wheel is excellent for length measurement.

The 6 mounting drill holes on a 48 mm pitch circle, each offset by 60°, allow optimum mounting and alignment of the rotary encoder. The angle of the spring arm can be individually adjusted from 0 ... 360° using 2 fastening screws. By completely loosening the fastening screws, the spring arm can also be mounted from the other side, allowing the direction of the spring load to be changed.

By means of the two front screws, the preload force can be increased in order to optimally adjust the contact pressure.

Dimensions

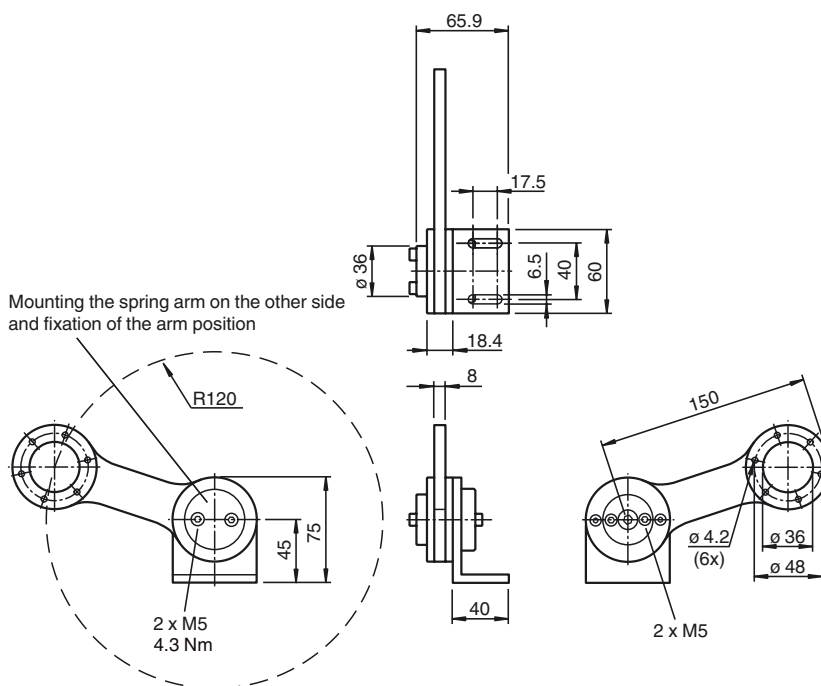

Technical data

Ambient conditions

Ambient temperature -30 ... 60 °C (-22 ... 140 °F)

Mechanical specifications

Material anodized aluminum
Mass 380 g

Note

Mounting Instructions

If required for your application, you can increase the preload force of the spring arm compared to the delivery state. This inevitably shortens the usable spring travel. For the adjustment, the spring arm must be installed in its application or in a suitable fixture in such a way that it is subjected to mechanical stress.

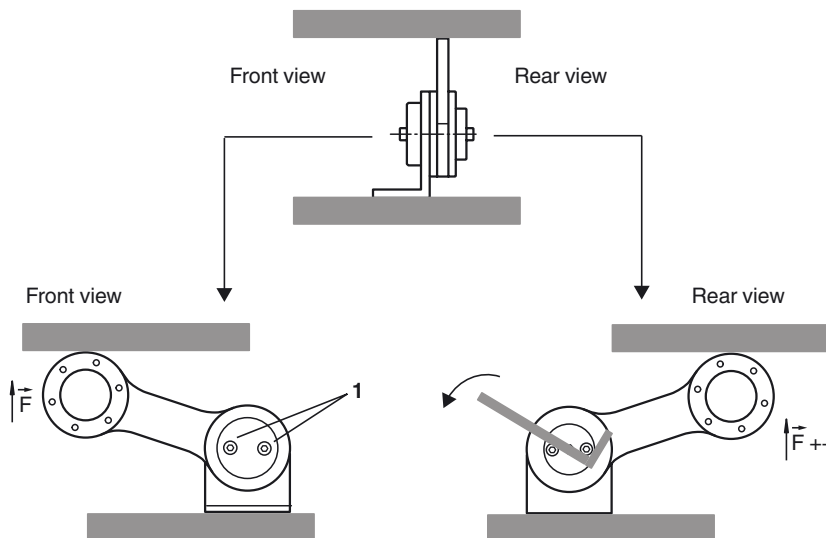

1. Loosen the two M5-hexagon socket screws (1) on the back of the spring arm.
2. Clamp a suitable tool on the front of the spring arm, such as an Allen wrench, between the two screws. Push the tool as far down as you want to increase the preload force and hold this position.
3. Fasten the two M5-hexagon socket screws (1) on the back of the spring arm with a torque of 4.3 Nm.