

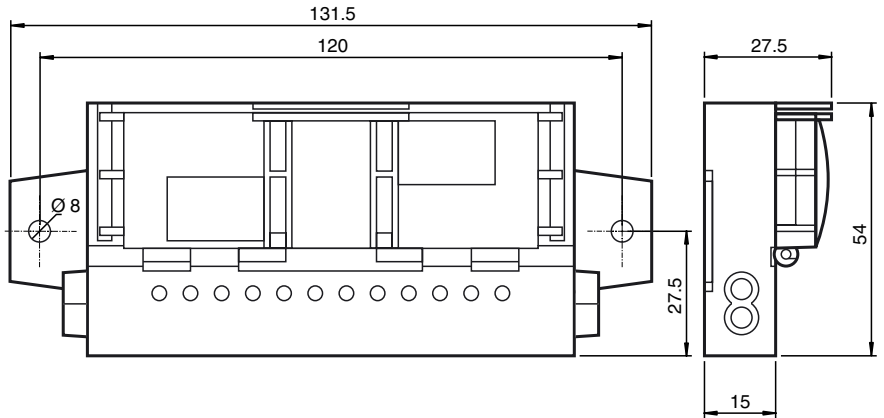

Dimensions

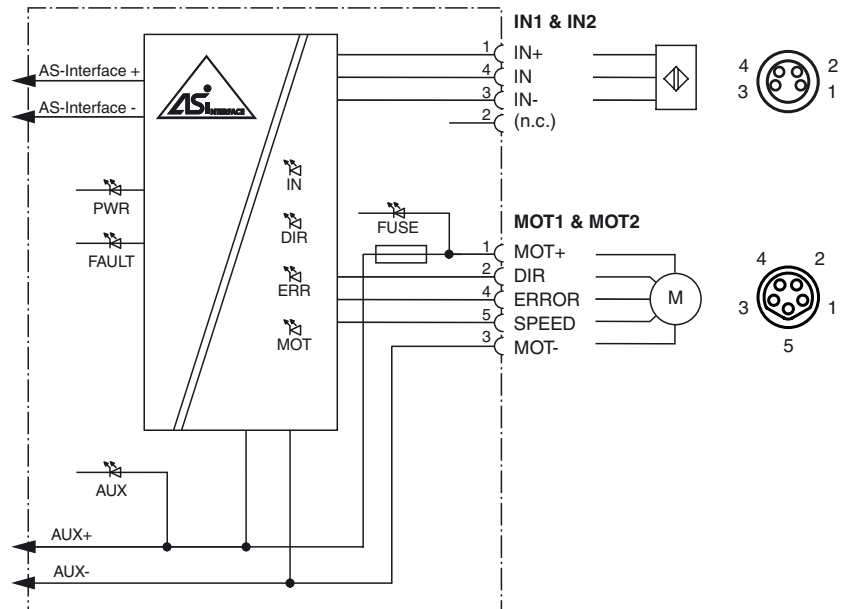

Electrical connection



Model number

VBA-4E3A-G20-ZEL/M1L-P6

G20 motor control module for Interroll EC310, Rulmeca BL3 and Itoh Denki PM500XK

Features

- A/B slave with extended addressing possibility for up to 62 slaves
- Inputs for 3-wire sensors
- Outputs for DC roller motors (drum motors)
- Connection of motors and sensors via M8 connectors
- Configurable start/stop ramps
- Communication monitoring
- Power supply of the inputs and outputs from the external auxiliary voltage
- Function display for bus, external auxiliary voltage, in- and outputs
- Cable piercing method with gold plated contact pins

Indicating / Operating means

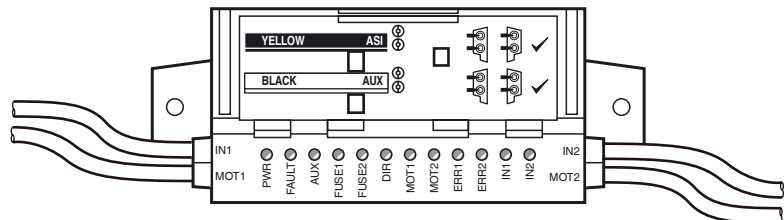

Release date: 2020-02-06 11:42 Date of issue: 2020-02-06 291127_eng.xml

Technical data

General specifications

Slave type	A/B slave
AS-Interface specification	V3.0
Required master specification	≥ V2.1
UL File Number	E223772 "For use in NFPA 79 Applications only"
MTBF	98 a
Compatible roller motors	Interroll EC310, Rulmeca BL3

Indicators/operating means

LED FAULT	error display; LED red red: communication error or address is 0 red flashing: overload of sensor supply or speed signal overload or external auxiliary voltage U_{AUX} missing
LED ERR	Motor fault; 2 LED yellow
LED PWR	AS-Interface voltage; green LED green: voltage OK green flashing: address 0 or sensor supply overload or speed signal overload or external auxiliary voltage U_{AUX} missing
LED AUX	ext. auxiliary voltage U_{AUX} ; dual LED green/red green: voltage OK red: reverse voltage
LED IN	switching state (input); 2 LED yellow
LED FUSE	Motor power supply; 2 green LEDs
LED DIR	Motor rotation direction; yellow LED
LED MOT	Motor active; 2 yellow LEDs

Electrical specifications

Auxiliary voltage (output)	U_{AUX}	18 ... 30 VDC PELV
Rated operating voltage	U_e	26.5 ... 31.6 V from AS-Interface
Rated operating current	I_e	≤ 35 mA

Input

Number/Type	2 Inputs for 3-wire sensors (PNP), DC
Supply	from external auxiliary voltage U_{AUX}
Current loading capacity	500 mA, overload and short-circuit protected
Input current	≤ 8 mA (limited internally)
Switching point	according to DIN EN 61131-2 0 (undamped) ≤ 0.5 mA 1 (damped) ≥ 2.0 mA
Signal delay	< 1 ms (input/AS-Interface)
Input filter	2 ms

Output

Number/Type	2 outputs for DC roller motors (MOT1, MOT2)
Supply	from external auxiliary voltage U_{AUX}
Current	max. 5 A per motor
Overload protection	fuse, $I^2t = 5.56 A^2s$
Velocity signal	U_S 1.4 ... 13 V at no-load $R_i = 5.6 k\Omega$, $R_{LOAD} \geq 35 k\Omega$ Control via parameter P2:0
Rotation direction signal	U_D Off / $\geq (U_{AUX} - 1.0 V)$ at no-load $R_i = 5.6 k\Omega$, $R_{LOAD} \geq 5 k\Omega$ AS-Interface data bit D2 = 0: $U_D = \text{Off}$
Motor fault	Digital input NPN, $U_0 = 3.3 V$, $R_i = 52 k\Omega$ 0 (no error) ≥ 40 μA 1 (error) ≤ 30 μA

Directive conformity

Electromagnetic compatibility	
Directive 2014/30/EU	EN 62026-2:2013

Standard conformity

Degree of protection	EN 60529:2000
Fieldbus standard	EN 62026-2:2013
Input	EN 61131-2:2007
Emitted interference	EN 61000-6-4:2007
AS-Interface	EN 62026-2:2013
Noise immunity	EN 61000-6-2:2005, EN 61326-1:2006, EN 62026-2:2013

Programming instructions

Profile	S-7.A.E
IO code	7
ID code	A
ID1 code	6
ID2 code	E

Data bits (function via AS-Interface)

	input	output
D0	MOT1 fault	MOT1 operation
D1	MOT2 fault	MOT2 operation
D2	IN1	MOT1/MOT2 rotation direction
D3	IN2	-

Ambient conditions

Ambient temperature	-25 ... 60 °C (-13 ... 140 °F)
Storage temperature	-25 ... 85 °C (-13 ... 185 °F)

Mechanical specifications

Degree of protection	IP54 according to EN 60529
Connection	AS-Interface, AUX: Insulation piercing technology Yellow flat cable/black flat cable Inputs/outputs: M8 round plug connector in accordance with EN 61076-2-104 Inputs: LF004-GS1-A (4-pin, bushing contacts, screw lock, A-coded) Matching connector: LM004-Gx1-A or similar Outputs: NF005-SS1-B (5-pin, bushing contacts, snap lock, B-coded). Matching connector: NM005-Sx1-B or similar

Function

The AS-Interface connecting module is a field module with two sensor inputs and two electronic outputs for controlling DC roller motors of the type Interroll EC310 and Rulmeca BL3 or compatible.

The compact housing can be installed directly in support profiles or conduits.

The connection to the AS-Interface network and power supply is made using the AS-Interface flat cable and insulation-piercing technology. The pivoted flat cable guide is secured using a snap fit. No tools are required. The sensor inputs and motor outputs are connected via cable outputs with M8 round plug connectors (inputs 4-pole female cordset with knurled thumb screw, outputs 5-pole snap-on female cordset). Power for the inputs and motors is provided by the external auxiliary voltage U_{AUX} .

The current switching state of the sensor inputs is indicated by the IN LEDs. The FUSE LEDs show that the power supply is applied to both motors. The MOT LEDs indicate when the motors are in operation (stop/operation). The DIR LED indicates the status of the rotation signal. The activation of the fault signal by a motor is displayed with the ERR LEDs.

The motors can be switched on and off individually by means of AS-Interface databits D0 and D1. D2 controls the rotation signal. The AS-Interface parameters P0 ... P2 select the voltage for the speed signal. The rotation and speed apply to both motors.

A start/stop ramp can be set for the speed signal for the controlled acceleration and stopping of the motors. The ramp duration can be selected from eight default values and can be configured over a defined sequence of data and parameters. The ramp selected in this way is saved permanently and is activated automatically after each power-on. The number of the ramp is displayed by a short flash of the ERR2, IN1, and IN2 LEDs in binary code. If the ramp number is set as 0 (no ramp), the six LEDs MOT1 to IN2 flash to show this.

The ramp is not effective if the rotation signal is switched while the motor is running. In other words, the reversal of rotation direction occurs immediately.

Note:

The communication monitor of the module deactivates the outputs if there is no communication between the AS-Interface and the module for more than 40 ms.

The IN1 and IN2 inputs suppress impulses of less than 2 ms.

A signal indicating an overload of the input supply, an overload of the speed signal, or the absence of the external auxiliary voltage is also transmitted to the AS-Interface master via the "peripheral fault" function. Communication via the AS-Interface continues.

Accessories**VBP-HH1-V3.0-KIT**

AS-Interface Handheld with accessory

VAZ-PK/G20-1M-V1-G

Adapter cable G20 module/hand-held programming device

VAZ-G20-MH

Mounting aid

Mass	220 g
Mounting	2 clips with Ø 8 mm drill hole
Cable length	0.35 m
Note	The flat cable routing is designed for 100 actuation cycles

Programming information

Parameter bit (programmable via AS-Interface)

P2	P1	P0	D0/D1	Speed signal U _S
x	x	x	0	< 1.5 V
0	0	0	1	3.96 V (3.92 ... 4.00 V)
0	0	1	1	4.78 V (4.73 ... 4.83 V)
0	1	0	1	5.61 V (5.55 ... 5.67 V)
0	1	1	1	6.44 V (6.38 ... 6.50 V)
1	0	0	1	8.50 V (8.42 ... 8.59 V)
1	0	1	1	9.63 V (9.53 ... 9.73 V)
1	1	0	1	10.00 V (9.90 ... 10.10 V)
1	1	1	1	7.26 V (7.19 ... 7.33 V); basic setting.

Start/stop ramp

Eight ramps configurable by AS-Interface parameter/data sequence.

Incline:

Constant, unaffected by final speed.

The ramp duration defines the time from stopping to maximum speed (U_S = 10V) or from max speed to stopping. If the final speed is low, the ramp duration is correspondingly shorter.**Display:**

Current ramp nos. 1 .. 7 in binary form through the flashing of the ERR2 (MSB), IN1, and IN2 (LSB) LEDs after power on. In the case of ramp number 0 (no ramp), the 6 MOT1 ... IN2 LEDs flash.

Start/stop ramp

Ramp number	Ramp duration (stop -> V _{max} or V _{max} -> stop)
0	No ramp (basic setting)
1	50 ms
2	100 ms
3	200 ms
4	300 ms
5	500 ms
6	1000 ms
7	1500 ms

Ramp configuration

permanent

Time frame:

10 s after setting D-OUT=4

Off-delay time:

Data/parameters: 10 ms per step

Display:

Configuration mode activated: 6 MOT1 ... IN2 LEDs flash

Step	P2:0	D3:0-OUT	D3:0-IN	Comment
1	3	4	x	
2	1	4	x	
3	6	4	x	
4	3	4	x	
5	1	4	x	
6	6	4	C	Configuration mode activated
7	6	Ramp number	C	Ramp number 0 ... 7 (see above)
8	4	Ramp number	A	Ramp number stored permanently
9	7	0	x	Normal mode

Troubleshooting:

If an error occurs in the defined sequence of parameter or data values during steps 1 to 6, then the module remains in normal mode.

If an error occurs in steps 7 or 8, the module outputs the value D-IN = E and waits until P = 7 and D-OUT = 0 are set before returning to normal mode.

If P = 7 and D-OUT = 0 are already set in step 7 or 8, the switch to normal mode takes place immediately without D-IN = E being output.

The stored ramp is not changed.