



## Model Number

ESS58-PN

## Features

- Industrial standard housing Ø58 mm
- PROFINET IRT
- 16 Bit singleturn
- Recessed hollow shaft
- Network loop through by means of integrated 2 port switch (IRT capable)
- IP address resettable
- No DIP switches for address setting
- Mechanical compatibility with all major encoders with fieldbus interface
- Status LEDs

## Description

In addition to the CANopen-, DeviceNet-, PRO-FIBUS- and AS-Interface encoders, we have broadened our product line of bus-capable absolute encoders with the ESM58 for Ethernet. Absolute singleturn rotary encoders deliver an absolute step value for each angle setting. This device has a maximum basic resolution of 65536 steps per revolution (16 bits).

The Ethernet interface of this absolute encoder supports the Profinet protocol. The integrated webserver provides Java applets, which allow the whole parameterisation of the encoder via any web browser. In addition to various functions like resolution adjustment, e-mail-services, change of the IP address and many others, the following operation modes can be selected:

- Polled Mode
- Cyclic Mode
- Change of State Mode

The device is mounted directly onto the application shaft, without any coupling. Rotation of the absolute encoder is prevented by a torque rest.

## Technical Data

### General specifications

Detection type	photoelectric sampling
Device type	Singleturn absolute encoder
UL File number	E223176 "For use in NFPA 79 Applications only", if UL marking is marked on the product.

### Functional safety related parameters

MTTF <sub>d</sub>	130 a
Mission Time (T <sub>M</sub> )	20 a
L <sub>10</sub>	1.9 E+11 at 6000 rpm and 20/40 N axial/radial shaft load
Diagnostic Coverage (DC)	0 %

### Electrical specifications

Operating voltage U <sub>B</sub>	10 ... 30 V DC
Power consumption P <sub>0</sub>	max. 4 W
Linearity	± 0.5 LSB (12 Bit) ,
Output code	binary code
Code course (counting direction)	programmable, cw ascending (clockwise rotation, code course ascending) cw descending (clockwise rotation, code course descending)

### Interface

Interface type	PROFINET IO
----------------	-------------

### Resolution

Single turn	up to 16 Bit
Overall resolution	up to 16 Bit

### Physical

Transfer rate	100 MBit/s
Cycle time	≤ 1 ms (IRT) ; ≤ 10 ms (RT)

### Connection

Connector	Ethernet: 2 sockets M12 x 1, 4-pin, D-coded Supply: 1 plug M12 x 1, 4-pin, A-coded
-----------	---

### Standard conformity

Degree of protection	DIN EN 60529, shaft side: IP64 (without shaft seal)/IP66 (with shaft seal) housing side: IP65 Stainless steel version (INOX): completely IP67
Climatic testing	DIN EN 60068-2-3, no moisture condensation
Emitted interference	EN 61000-6-4:2007
Noise immunity	EN 61000-6-2:2005
Shock resistance	DIN EN 60068-2-27, 100 g, 6 ms
Vibration resistance	DIN EN 60068-2-6, 10 g, 10 ... 2000 Hz

### Ambient conditions

Operating temperature	-40 ... 85 °C (-40 ... 185 °F)
Storage temperature	-40 ... 85 °C (-40 ... 185 °F)

### Mechanical specifications

Material	housing: powder coated aluminum flange: aluminum shaft: stainless steel
Combination 1	housing: powder coated aluminum flange: aluminum shaft: stainless steel
Combination 2 (Inox)	housing: stainless steel 1.4305 / AISI 303 flange: stainless steel 1.4301 / AISI 304 shaft: stainless steel 1.4305 / AISI 303
Mass	approx. 360 g (combination 1) approx. 910 g (combination 2)
Rotational speed	max. 12000 min <sup>-1</sup>
Moment of inertia	30 gcm <sup>2</sup>
Starting torque	≤ 3 Ncm (version without shaft seal)
Tightening torque, fastening screws	max. 1.8 Nm
Shaft load	
Angle offset	± 0.9 °
Axial offset	static: ± 0.3 mm, dynamic: ± 0.1 mm
Radial offset	static: ± 0.5 mm, dynamic: ± 0.2 mm

### Approvals and certificates

UL approval	cULus Listed, General Purpose, Class 2 Power Source , if UL marking is marked on the product.
-------------	---

Dimensions

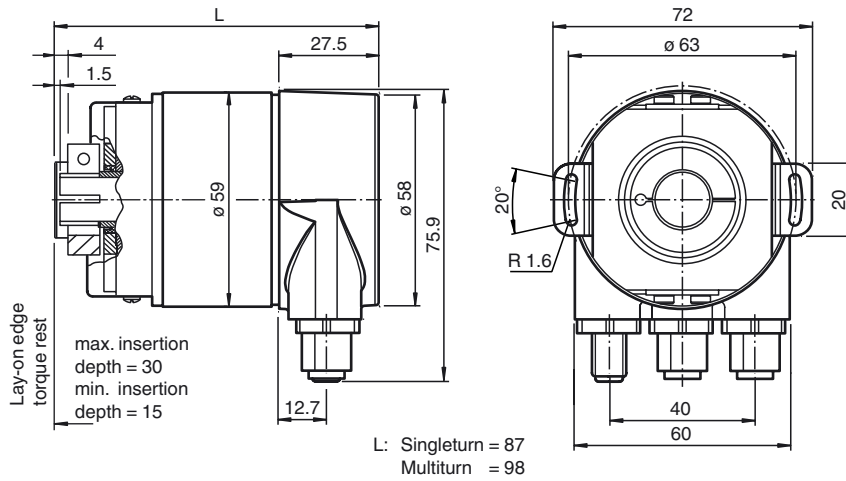

Electrical connection

Pin	Voltage supply Male connector M12 x 1, 4-pin, A-coded	Ethernet Female connector M12 x 1, 4-pin, D-coded
1	+VS (15 ... 30 VDC)	Tx +
2	n. c.	Rx +
3	GND (0 V)	Tx -
4	n. c.	Rx -

--	--

Indicators

Diagnostic LEDs

LED	Color	Description for LED = ON
Active1	Yellow	Incoming and outgoing data traffic for port 1
Link1*	Green	Connection to other Ethernet devices on port 1
Active2	Yellow	Incoming and outgoing data traffic for port 2
Link2*	Green	Connection to other Ethernet devices on port 2
Stat1	Green	Status 1, details see table below
Stat2	Red	Status 2, details see table below

\* flashes with 2 Hz if engineering identification call is activated and link connection is available

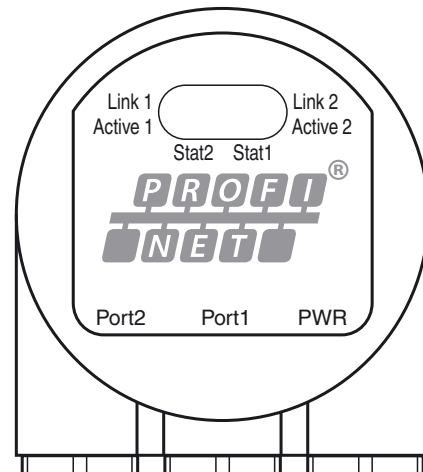

Stat1 (green)	Stat2 (red)	Meaning	Cause
off	off	No power	
on	on	No connection to another device Criteria: no data exchange	<ul style="list-style-type: none"> <li>bus disconnected</li> <li>Master not available / switched off</li> </ul>

Release date: 2019-07-17 11:35 Date of issue: 2019-07-17 t37195\_eng.xml

on	flashes <sup>1)</sup>	Parameterization fault, no data exchange Criteria: data exchange correct. However, the slave did not switch to the data exchange mode.	<ul style="list-style-type: none"> <li>Slave not configured yet or wrong configuration</li> <li>Wrong station address assigned (but not outside the permitted range)</li> <li>Actual configuration of the slave differs from the nominal configuration</li> </ul>
on	off	Data exchange. Slave and operation ok.	

1) flashing frequency 0.5 Hz for at least 3 seconds

**Order code**

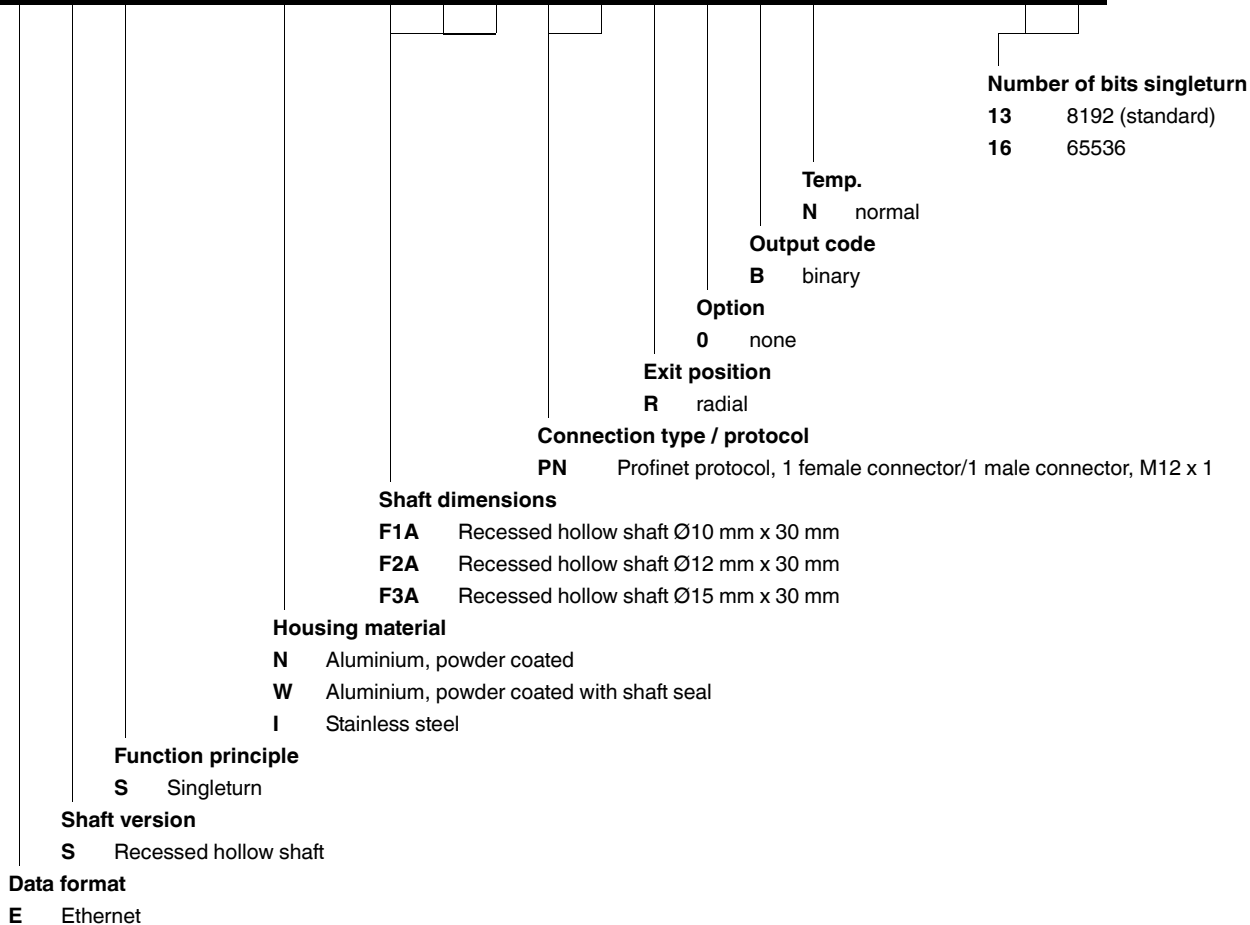

Release date: 2019-07-17 11:35 Date of issue: 2019-07-17 t37195\_eng.xml