



DeviceNet

Model Number

DVM78E

Features

- Up to 30 Bit multiturn
- ATEX approval
- IECEx approval
- Flameproof enclosure
- Removable connection cap

Description

Absolute encoders deliver an absolute step value for each angle setting. All these values are represented by code samples on one or more code disks. The code disks are screened by an infrared LED and the bit obtained sample is detected by an optical array. Its signals are electronically amplified and are forwarded on to the interface for processing.

The absolute encoder has a maximum basic resolution of 65536 steps per revolution (16 Bits). In the multiturn design, additional up to 16384 revolutions (14 Bits) can be resolved. This results in a total maximum resolution of 1073741824 steps (30 Bits).

The integrated CAN bus interface of the absolute encoder supports all DeviceNet functions. The following operating modes can be programmed, and can be selectively turned on or off:

- Polled mode
- Change of state mode
- Cyclic mode

The device is designed for shaft assembly and is available in servo flange or clamping flange design. The bus electronics module is integrated into the removable housing cover. This makes it possible to mount or replace the new rotary encoders and the matching bus electronics separately during installation or service.

Technical Data

General specifications

Detection type	photoelectric sampling
Device type	Multiturn absolute encoder

Functional safety related parameters

MTTF _d	25 a
Mission Time (T _M)	20 a
L ₁₀	7.7 E+9 at 3000 rpm
Diagnostic Coverage (DC)	0 %

Electrical specifications

Operating voltage U _B	10 ... 30 V DC
No-load supply current I ₀	max. 230 mA at 10 V DC max. 100 mA at 24 V DC
Time delay before availability t _v	< 250 ms
Linearity	± 2 LSB at 16 Bit, ± 1 LSB at 13 Bit, ± 0,5 LSB at 12 Bit
Output code	binary code
Code course (counting direction)	cw ascending (clockwise rotation, code course ascending) cw descending (clockwise rotation, code course descending)

Interface

Interface type	DeviceNet
Resolution	
Single turn	up to 16 Bit
Multiturn	14 Bit
Overall resolution	up to 30 Bit
Transfer rate	max. 0.5 MBit/s

Connection

Cable	Ø 10.2 mm, Radox 9 x 0.5 mm ²
Terminal compartment	see ordering information

Standard conformity

Degree of protection	DIN EN 60529, IP66
Climatic testing	DIN EN 60068-2-3, no moisture condensation
Emitted interference	EN 61000-6-4:2007
Noise immunity	EN 61000-6-2:2005
Shock resistance	DIN EN 60068-2-27, 100 g, 3 ms
Vibration resistance	DIN EN 60068-2-6, 10 g, 10 ... 2000 Hz

Ambient conditions

Operating temperature	-40 ... 70 °C (-40 ... 158 °F)
Storage temperature	-40 ... 85 °C (-40 ... 185 °F)

Mechanical specifications

Material	
Combination 1	housing: anodized aluminum flange: anodized aluminum shaft: Stainless steel 1.4401 / AISI 316
Combination 2 (Inox)	housing: stainless steel 1.4404 / AISI 316L flange: stainless steel 1.4404 / AISI 316L shaft: Stainless steel 1.4401 / AISI 316
Mass	approx. 2600 g (combination 1) approx. 3900 g (combination 2)
Rotational speed	max. 3000 min ⁻¹
Moment of inertia	180 gcm ²
Starting torque	≤ 4 Ncm
Shaft load	
Axial	60 N
Radial	80 N

Data for application in connection with hazardous areas

EU-type examination certificate	ITS 15 ATEX 18372X IECEx ITS 15.0061X
Marking	⊕ II 2G Ex d IIC T5 Gb ⊕ II 2D Ex tb IIIC T100°C Db
Directive conformity	
Directive 2014/34/EU	IEC 60079-0:2011 , EN 60079-0:2012+A11:2013 , IEC 60079-1:2014 , EN 60079-1:2014 , IEC 60079-31:2013 , EN 60079-31:2014

Dimensions

Encoder length L

Version		Length L
Radial cable exit	Clamping flange	118 mm
	Servo flange	118 mm
Axial cable exit	Clamping flange	134 mm
	Servo flange	134 mm

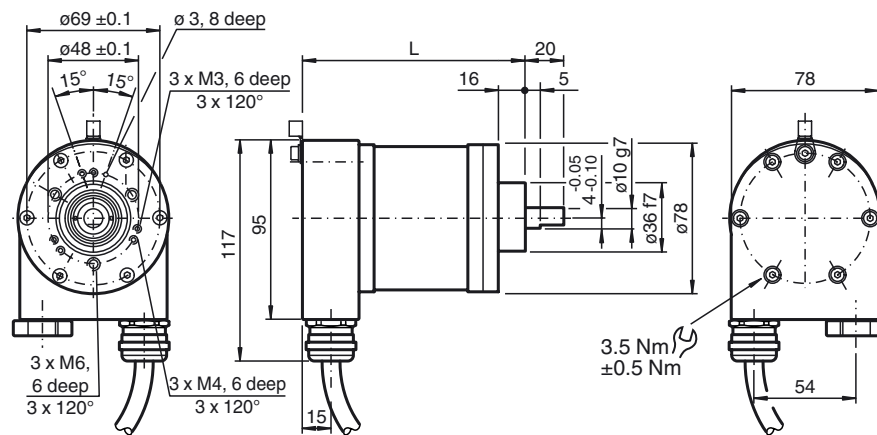

Clamping flange, cable exit radial

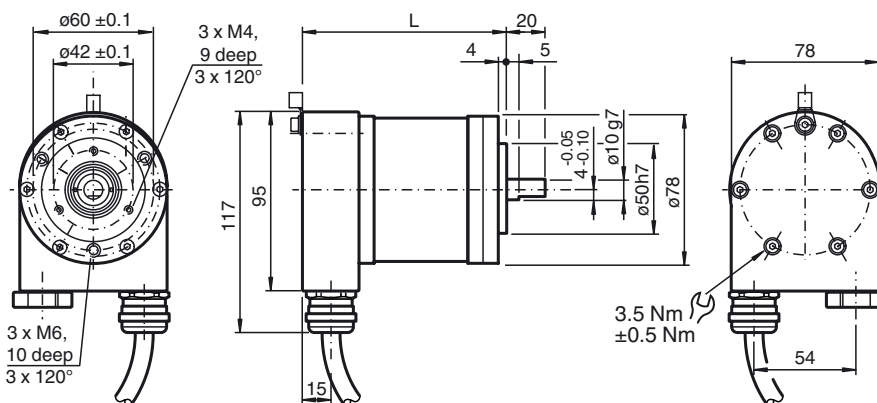

Servo flange, radial cable exit

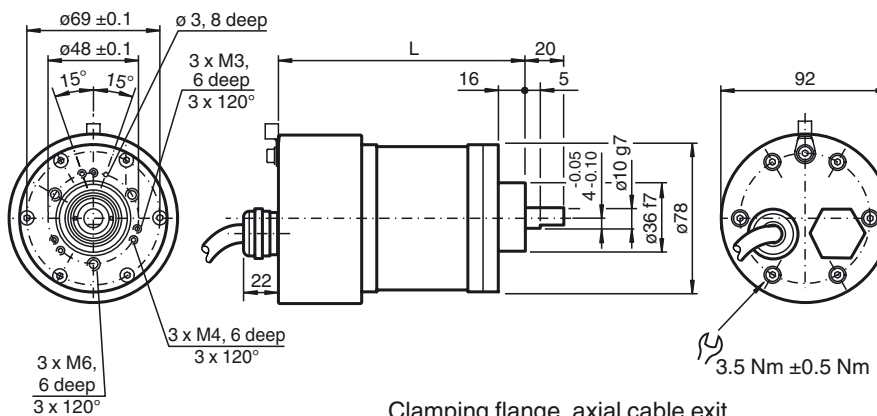

Clamping flange, axial cable exit

Release date: 2019-08-23 11:33 Date of issue: 2019-08-23 t160347_eng.xml

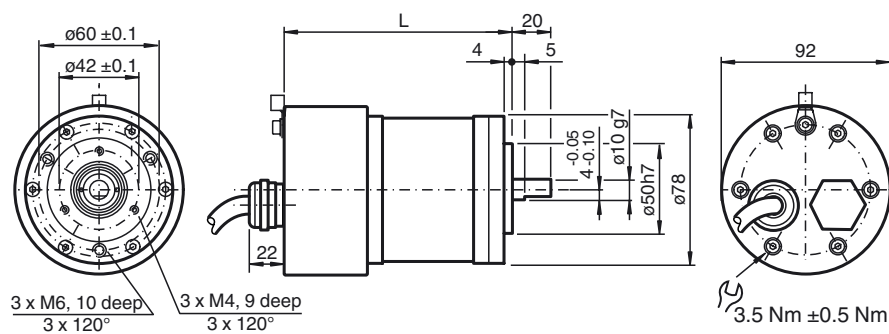

Servo flange, axial cable exit

Shaft 12 mm

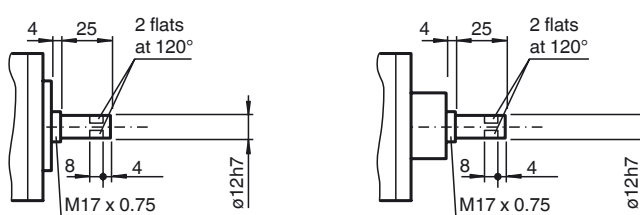

Electrical connection

Terminal	Cable	Explanation
(-)	1	- Power supply
(+)	2	+ Power supply
L	3	CAN low
H	4	CAN high
G	5	CAN ground
L	6	CAN low
H	7	CAN high
G	8	CAN ground
⊥	green / yellow	Ground connection of encoder housing

Indicating and operating elements

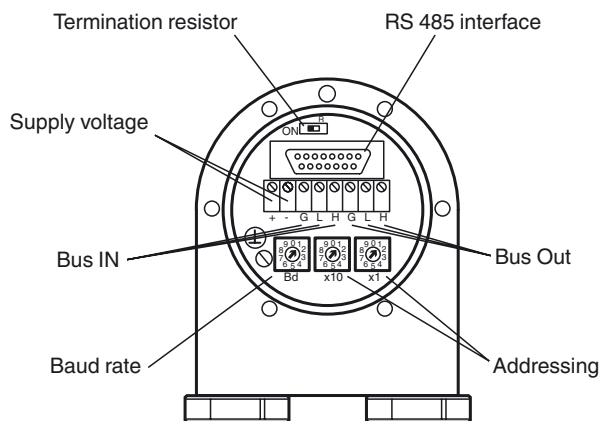

Release date: 2019-08-23 11:33 Date of issue: 2019-08-23 11:33 1160347_eng.xml

Refer to "General Notes Relating to Pepperl+Fuchs Product Information".

Adjusting the participant address

The participant address can be adjusted with the rotary switches. The address can be defined between 1 and 63, and may only be assigned once.

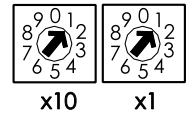

Adjusting the termination resistor

The terminating resistor R_T (121 Ω) can be connected to the circuit by means of the switch:

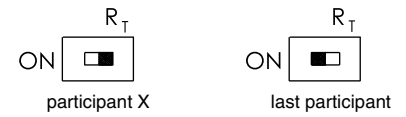

Baud rate adjustment

Baud rate [kBit/s]	Switch position
125	0
250	1
500	2
125	3
reserved	4 ... 9

Programmable CAN operating modes

Mode	Explanation
Polled mode	The connected host requests the current actual position value via a telegram. The absolute encoder reads in the current position, calculates all parameters that may have been set and then sends back the actual process value.
Cyclic mode	The absolute encoder sends the current process value depending on a programmable timer. This can cause the bus load to be reduced since the member on the network only sends a message after a specific amount of time without a prompt from the master.
Change of state mode	The absolute encoder monitors the current process value and transfers the current value by itself if there is any change in the value. This can cause the bus load to be reduced, since the member on the network only sends a message if there has been a change.

Programmable rotary encoder parameters

Parameter	Explanation
Operating parameter	The direction of rotation (complement) can be specified by parameter as the operating parameter. This parameter determines the direction of rotation in which the output code will be rising or descending.
Resolution per revolution	The "Resolution" parameter is used to program the rotary encoder so that a desired number of steps can be implemented in reference to a revolution.
Overall resolution	This parameter indicates the desired number of measurement units of the entire travel length. This value must not exceed the overall resolution of the absolute encoder. If the absolute encoder is used in infinite mode, the overall resolution parameter can only take on values that are powers of 2 (2x).
Preset value	The preset value is the desired position value that must be achieved for a specific physical setting of the axis. The preset value parameter is used to set the actual position value to the desired actual process value.

Ordering information



D	V	M	7	8	E	-	0							0	B					
																Number of singleturn bits				
																12 4096				
																13 8192				
																16 65536				
																Number of multiturn bits				
																12 4096				
																14 16384				
																Housing material				
																N Aluminum				
																I INOX 1.4404 (AISI 316L)				
																Output code				
																B Binary				
																Option 2				
																0 None				
																Exit position				
																A Axial				
																R Radial				
																Connection type				
																K2 Cable, 9-wire, 2 m				
																K5 Cable, 9-wire, 5 m				
																DR Terminal compartment, 2 cable glands				
																KR Terminal compartment, 1 cable gland, 1 stopping plug				
																Flange version				
																1 Clamping flange				
																2 Servo flange				
																Shaft dimension				
																01 Shaft Ø10 mm x 20 mm				
																02 Shaft Ø12 mm x 25 mm				
																Option 1				
																E Explosion-proof, standard IP66				
																Functional principle				
																M Multiturn				
																Shaft version				
																V Solid shaft				
																Data format				
																D DeviceNet				

Release date: 2019-08-23 11:33 Date of issue: 2019-08-23 11:33 1160347_eng.xml

Refer to "General Notes Relating to Pepperl+Fuchs Product Information".