



Model Number

UC4000-L2M-E6-T-2M

Single head system

Features

- Extended temperature range
- Cable connection
- Rugged metal base
- Sensor head bidirectional and rotatable
- Function indicators visible from all directions
- Selectable sound lobe width
- Programmable

Diagrams

Characteristic response curve

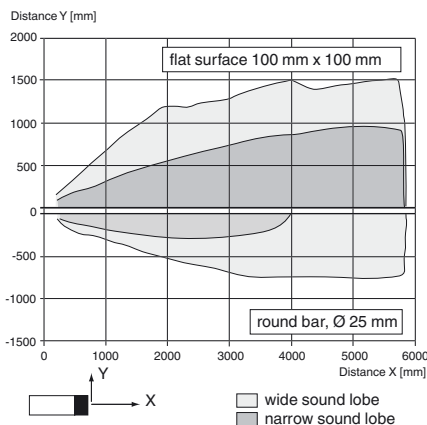

Release date: 2019-10-25 07:53 Date of issue: 2019-10-25 299132_eng.xml

Technical data

General specifications

Sensing range	200 ... 4000 mm
Adjustment range	240 ... 4000 mm
Dead band	0 ... 200 mm
Standard target plate	100 mm x 100 mm
Transducer frequency	approx. 85 kHz
Response delay	minimum : 110 ms factory setting: 280 ms

Indicators/operating means

LED green	Operating display
LED yellow 1	switching state switch output 1
LED yellow 2	switching state switch output 2
LED red	error

Electrical specifications

Operating voltage U_B	10 ... 30 V DC , ripple 10 % _{SS}
No-load supply current I_0	≤ 50 mA

Interface

Interface type	Serial interface (programming adapter required) 9600 BPS, no parity, 8 data bits, 1 stop bit
----------------	---

Input/Output

Input/output type	1 synchronization connection, bidirectional
0 Level	0 ... 1 V
1 Level	4 V ... U_B
Input impedance	> 12 k Ω
Output rated operating current	< 12 mA
Pulse length	0.5 ... 300 ms (level 1)
Pulse interval	≥ 62.5 ms (level 0)
Synchronization frequency	≤ 16 Hz
Common mode operation	≤ 17 Hz / n , n = number of sensors , n ≤ 10
Multiplex operation	(factory setting: n = 5)

Output

Output type	2 switch outputs PNP, NO/NC, programmable
Rated operating current I_e	200 mA , short-circuit/overload protected
Voltage drop U_d	≤ 2 V
Repeat accuracy	≤ 0.1 % of full-scale value
Switching frequency f	≤ 2.8 Hz
Range hysteresis H	programmable , preset to 1 mm
Temperature influence	< 1.5 % of full-scale value

Ambient conditions

Ambient temperature	-40 ... 70 °C (-40 ... 158 °F)
Storage temperature	-40 ... 85 °C (-40 ... 185 °F)

Mechanical specifications

Connection type	cable , 5-pin
Degree of protection	IP67
Material	
Housing	PA-GF35
Cable	PUR
Transducer	epoxy resin/hollow glass sphere mixture; polyurethane foam
Cable	
Sheath diameter	7.25 mm
Bending radius	> 37.3 mm , fixed > 74.7 mm , moving
Core cross-section	5 x 0.82 mm ²
Length L	2 m
Mass	355 g

Factory settings

Output 1	near switch point: 240 mm far switch point: 4000 mm Output mode: Window mode output behavior: NO contact
Output 2	near switch point: 500 mm far switch point: 2000 mm Output mode: Window mode output behavior: NO contact
Beam width	wide
Evaluation procedure	averaging (MxN) M = 5 N = 2

General information

Supplementary information	Switch settings of the external programming adapter: "output load": pull-down "output logic": inv
---------------------------	---

Compliance with standards and directives

Standard conformity	
Standards	EN 60947-5-2:2007+A1:2012 IEC 60947-5-2:2007 + A1:2012

Approvals and certificates

EAC conformity	TR CU 020/2011
UL approval	cULus Listed, General Purpose
CCC approval	CCC approval / marking not required for products rated ≤36 V

Dimensions

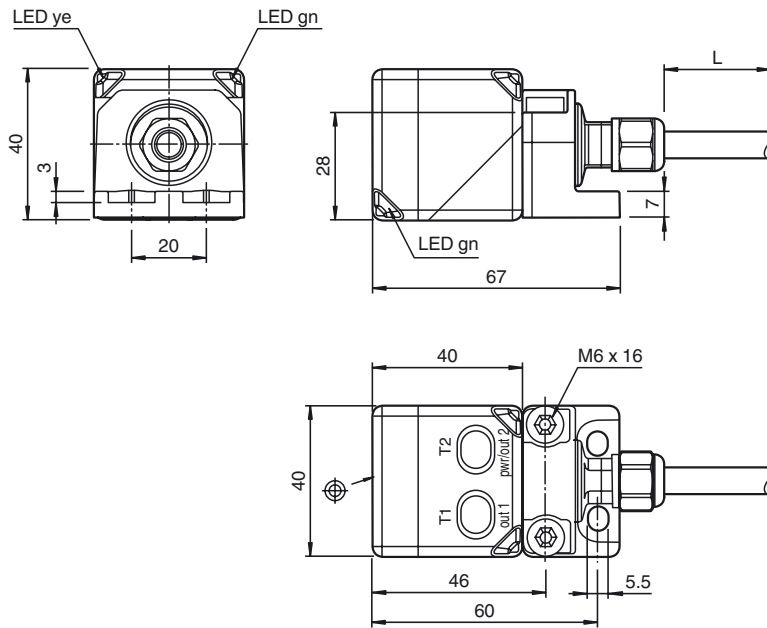

Additional Information

Switching output modes

1. Switch point mode

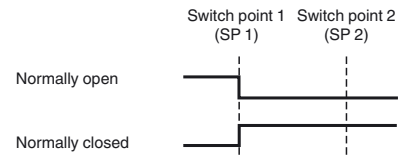

2. Window mode



3. Hysteresis mode

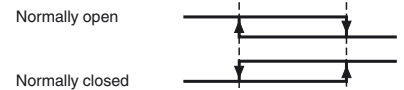

Electrical Connection

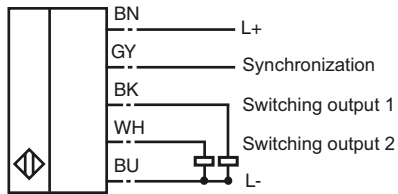

Wire colors in accordance with EN 60947-5-2

1	BN	(brown)
2	WH	(white)
3	BU	(blue)
4	BK	(black)
5	GY	(gray)

Accessories

UC-PROG1-USB

Programming adapter

V15S-G-0,3M-PUR-WAGO

Male cordset, M12, 5-pin, PUR cable with WAGO terminals

Description of Sensor Functions

Adjustment possibilities

The sensor is equipped with 2 switching outputs with 2 programmable switch points each. The programming of the switch points, the output mode, the output logic and the beam width can be done in two different ways:

- Using the sensor's programming buttons
- Using the sensor's serial interface. This method requires an external programming adapter and the corresponding software. You will find the download link for the software at www.pepperl-fuchs.com on the product page of the sensor.

Synchronization

Release date: 2019-10-25 07:53 Date of issue: 2019-10-25 299132_eng.xml

The sensor features a synchronization input for suppressing ultrasonic mutual interference ("crosstalk"). The following synchronization modes are available:

1. Automatic multiplex mode
2. Automatic master slave common mode
3. Externally controlled synchronization

Further Documentation

For information on programming via programming buttons and synchronisation you may refer to the commissioning instruction.