



## Model Number

NBN3-F31K-E8-K

## Features

- Direct mounting on standard actuators
- Fixed setting
- LED for power on
- LEDs for switching state of sensor and solenoid valve

## Application

### Note

The connections to this sensor are sealed with stopping plugs to protect against dirt and moisture. If not all of the connections are used in your application, then seal the remaining stopping plugs on the sensor permanently or check during initial installation and when performing regular maintenance work that the stopping plugs are secure and impermeable. If necessary, tighten the stopping plugs to a torque of 1 Nm.

## Accessories

### BT65A

Activator for F31 series

### BT65X

Activator for F31 series

### BT115A

Activator for F31 series

### BT115X

Activator for F31 series

### BT65B

Activator for F31 series

### BT115B

Activator for F31 series

## Technical Data

### General specifications

Switching function		2 x normally open (NO)
Output type		PNP
Rated operating distance	$s_n$	3 mm
Installation		flush mountable
Output polarity		DC
Assured operating distance	$s_a$	0 ... 2.43 mm
Actual operating distance	$s_r$	2.7 ... 3.3 mm typ.
Reduction factor $r_{Al}$		0.5
Reduction factor $r_{Cu}$		0.4
Reduction factor $r_{304}$		1
Reduction factor $r_{Si37}$		1.2
Output type		4-wire

### Nominal ratings

Operating voltage	$U_B$	10 ... 30 V DC
Switching frequency	$f$	0 ... 500 Hz
Hysteresis	$H$	typ. 5 %
Reverse polarity protection		all connections
Short-circuit protection		pulsing
Voltage drop	$U_d$	$\leq 3$ V
Operating current	$I_L$	0 ... 100 mA
Off-state current	$I_r$	0 ... 0.5 mA typ. 0.1 $\mu$ A
No-load supply current	$I_o$	$\leq 25$ mA
Operating voltage indicator		LED, green
Switching state indicator		LED, yellow
Valve status indicator		LED, yellow

### Functional safety related parameters

MTTF <sub>d</sub>	780 a
Mission Time ( $T_M$ )	20 a
Diagnostic Coverage (DC)	0 %

### Valve circuit

Voltage	max. 32 V DC
Current	max. 240 mA
Short-circuit protection	no
Reverse polarity protection	yes, with reversed output LED is out of function, therefore more power for solenoid valve

### Ambient conditions

Ambient temperature	-25 ... 70 °C (-13 ... 158 °F)
---------------------	--------------------------------

### Mechanical specifications

Connection (system side)	Cage tension spring terminals
Core cross-section (system side)	1.5/2.5 mm <sup>2</sup> flexible/rigid
Connection (valve side)	Cage tension spring terminals
Core cross-section (valve side)	1.5/2.5 mm <sup>2</sup> flexible/rigid
Housing material	PBT
Sensing face	PBT
Degree of protection	IP67
Tightening torque, housing screws	1 Nm
Tightening torque, cable gland	M20 x 1.5 ; $\leq 7$ Nm M12 x 1.5 ; $\leq 1.5$ Nm

### Compliance with standards and directives

Standard conformity	
Standards	EN 60947-5-2:2007 EN 60947-5-2/A1:2012 IEC 60947-5-2:2007 IEC 60947-5-2 AMD 1:2012

### Approvals and certificates

UL approval	cULus Listed, General Purpose
CSA approval	cCSAus Listed, General Purpose
CCC approval	CCC approval / marking not required for products rated $\leq 36$ V

Dimensions

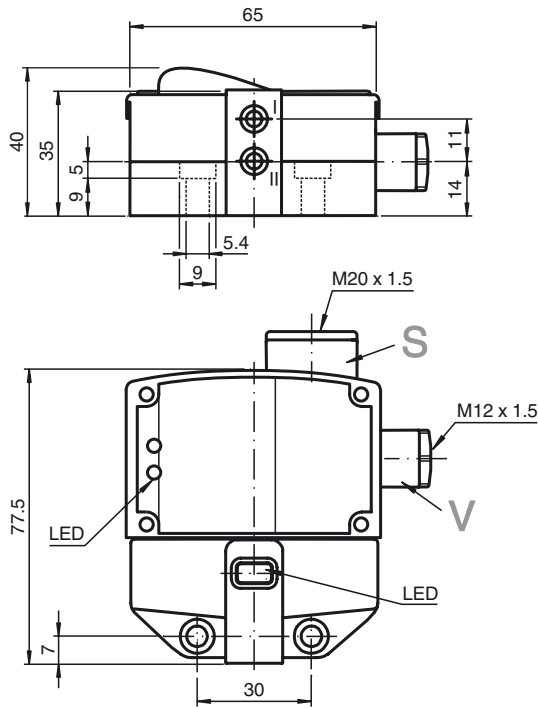

Electrical Connection

