



Model Number

MotionScan

Combined sensor

Features

- Combined sensor for opening and securing automatic sliding doors
- Radar opening impulse
- Closing edge safety mechanism with diffuse sensor
- Safety mechanism in accordance with EN 16005
- Extra-large, adjustable protection field in front of the door
- Door learn function

Product information

The two-in-one MotionScan sensor for opening and securing automatic sliding doors allows doors to be opened in a timely manner thanks to its large radar detection field. A large, adjustable infrared protection field ensures maximum safety. The special Door Learn function enables a protection field to be defined both in front of and behind the door. The MotionScan works reliably with a wide range of floor surfaces. It is incredibly easy to install and operate with single-button operation and multicolor LED display.

Dimensions

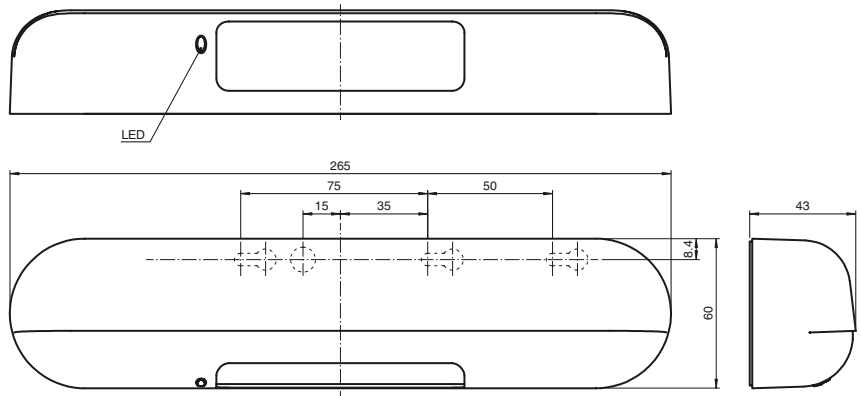

Electrical connection

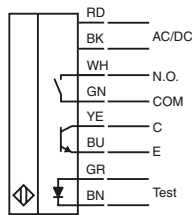

Indicators/operating means

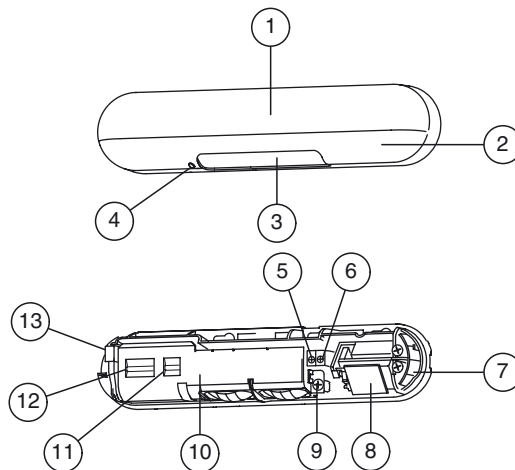

1	Cover
2	Radar detection window
3	IR detection window
4	Indicator LED (red, green, blue)
5	IR sensitivity control
6	Radar sensitivity control
7	Range mask
8	Radar sensor unit
9	Depth adjustment screw (IR range)
10	IR sensor unit
11	DIP switch Y
12	DIP switch X
13	Connection

Release date: 2019-12-18 11:20 Date of issue: 2019-12-18 285849_eng.xml

Refer to "General Notes Relating to Pepperl+Fuchs Product Information".

Technical data

General specifications

Detection field	AIR, adjustable , total field: 2400 mm x 1000 mm (WxD) for a mounting height of 2200 mm
Detection field	Radar sensor 2500 mm x 4000 mm (d x w) at installation height of 2200 mm and 45° angle
Detection range max.	0 ... 3200 mm
Light source	3 Series
Light type	modulated infrared light
Setting angle	-8 ... 4 °
Operating frequency	24.15 ... 24.25 GHz K-Band , Radar sensor
Transmitter radiated power (EIRP)	< 20 dBm

Functional safety related parameters

Performance level (PL)	PL d
Category	Cat. 2
MTTF _d	339.83 a
Diagnostic Coverage (DC)	81.52 %

Indicators/operating means

Function indicator	LED green/blue/red/orange
Control elements	DIP-switch
Control elements	sensitivity adjustment
Parameterization indicator	LED flashes when in adjustment mode Fast orange

Electrical specifications

Operating voltage	U _B	12 ... 24 V DC / 12 ... 24 V AC +/- 10%, 50 - 60 Hz
No-load supply current	I ₀	≤ 80 mA at 24 V DC ≤ 150 mA at 12 V:
Power consumption	P ₀	2.5 VA

Input

Activation current	at 24 V DC 6 mA
Test input	active with +U _B

Output 1

Output type	Infrared, optocoupler
Switching voltage	48 V DC
Switching current	300 mA resistive load
De-energized delay	0.5 s
Switching type	light/dark on selectable programmable
Response time	100 ms up to 200 ms

Output 2

Output type	Radar, relay
Switching voltage	48 V DC
Switching current	100 mA resistive load
De-energized delay	1.5 s
Switching type	NO/NC programmable
Response time	100 ms up to 200 ms

Conformity

Functional safety	ISO 13849-1
Product standard	EN 12978

Ambient conditions

Operating temperature	-20 ... 60 °C (-4 ... 140 °F)
Storage temperature	-20 ... 60 °C (-4 ... 140 °F)
Relative humidity	max. 80 %

Mechanical specifications

Mounting height	max. 3200 mm
Degree of protection	IP54 (iwhen mounted)
Connection	Male connector 8-pin , Connecting cable included with delivery
Material	
Housing	ABS
Mass	approx. 260 g
Dimensions	(W x H x D) 265 mm 60 mm 43 mm
Note	Please refer to the package insert for information on how to mount and install the sensor correctly.

General information

Scope of delivery	sensor , cable , 2 screws , Mounting aid , Instruction leaflet
-------------------	--

Suitable series

Series	MotionScan
--------	------------

Approvals and certificates

CE conformity	2014/53/EU This device can be used in all countries within the European Union. In other countries, all applicable national regulations must be observed.
EAC conformity	TR CU 020/2011
FCC approval	No - Use in North America is not permitted.
CCC approval	CCC approval / marking not required for products rated ≤36 V

Typical applications

- Two-in-one sensor for opening and securing automatic sliding doors

Accessories

MotionScan Intern. Mounting

Ceiling mount kit

MotionScan Mount. Bracket

Mounting bracket

MotionScan Weather Cap

Weather cover

Release date: 2019-12-18 11:20 Date of issue: 2019-12-18 285849_eng.xml

Curves/Diagrams

IR:

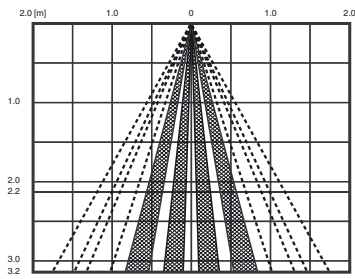

Far: Setting 4°

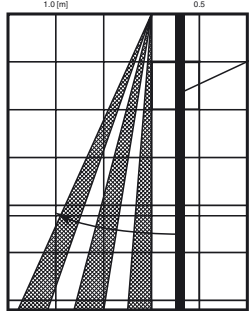

Near: Setting -8°

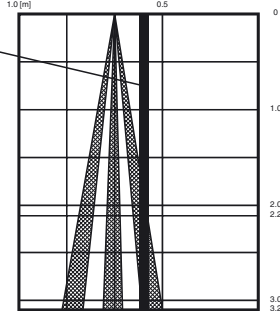

Radar:

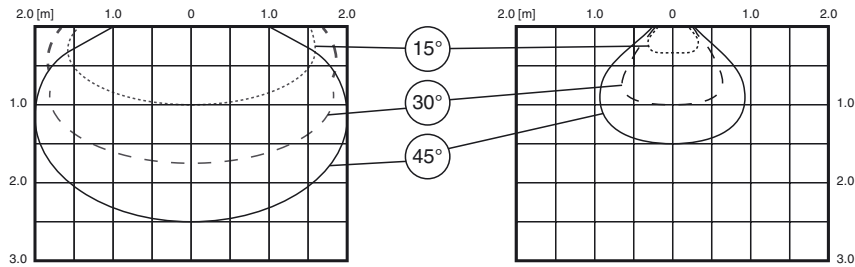

Release date: 2019-12-18 11:20 Date of issue: 2019-12-18 285849_eng.xml

Refer to "General Notes Relating to Pepperl+Fuchs Product Information".

Pepperl+Fuchs Group
www.pepperl-fuchs.com

USA: +1 330 486 0001
fa-info@us.pepperl-fuchs.com

Germany: +49 621 776 1111
fa-info@de.pepperl-fuchs.com

Singapore: +65 6779 9091
fa-info@sg.pepperl-fuchs.com