



Model Number

SBL-8-H-900-IR-SL-V-Z-4568

Background suppression sensor with 4-pin, M12 x 1 connector and fixed cable with 4-pin, M12 socket

Features

- Background suppression sensor for roller conveyors
- For installation between the rollers on a roller conveyor
- Very small black-white difference
- Adjustable detection range
- Can be connected in series
- ON/Off delay adjustable
- 3 in 1: Sensor, pneumatic valve and integrated control logic

Product information

Sensors of the SBL series are used to easily control material flow on roller conveyors in material handling and other branches.

The SBL series is a precise background suppression sensor according to the 3 element method. The sensor features superior background suppression and a very good ambient light immunity. Material and transport container of all colors and opacities are reliably detected.

The special design allows the sensor to be mounted between the rollers of a roller conveyor or any other conveying unit. Mounting between the rollers is easy and protects the sensor.

Dimensions

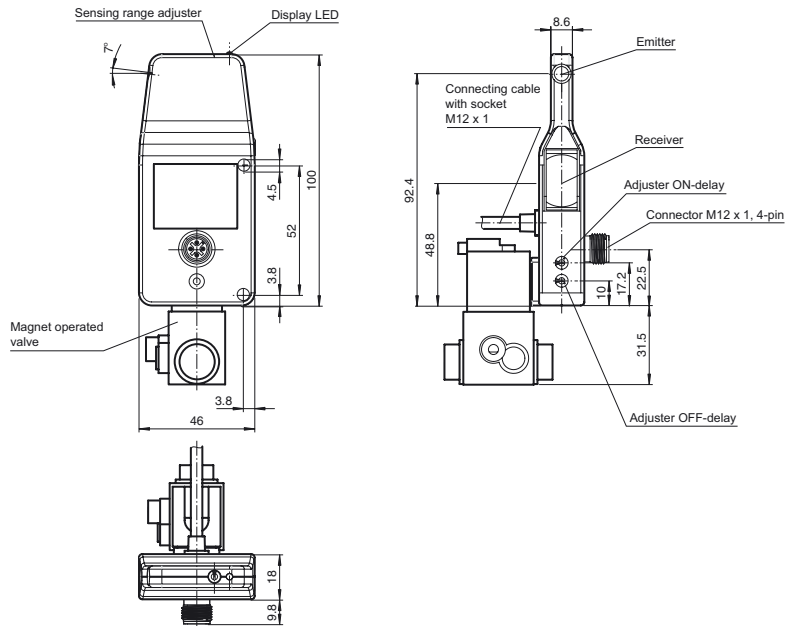

Electrical connection

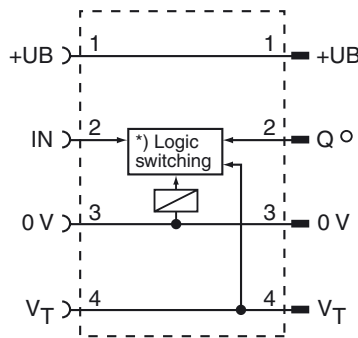

*) see table to functionality on the following page

○ = Light on
● = Dark on

Pinout

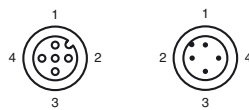

Indicators/operating means

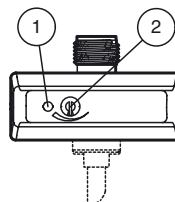

1	Signal display	yellow
2	Sensing range adjuster	

Release date: 2019-09-18 15:49 Date of issue: 2019-09-18 223837_eng.xml

Technical data**General specifications**

Detection range	40 ... 900 mm
Detection range min.	40 ... 340 mm
Detection range max.	40 ... 900 mm
Adjustment range	340 ... 900 mm
Reference target	standard white 200 mm x 200 mm
Light source	IREL
Light type	modulated infrared light , 880 nm
Black/White difference (6%/90%)	< 10 %
Diameter of the light spot	approx. 60 mm at detection range 900 mm
Cascadability	At 20°C: max. 38 sensors per line
Ambient light limit	continuous light 30000 Lux , Fluorescent lamp 5000 Lux

Functional safety related parameters

MTTF _d	1100 a
Mission Time (T _M)	20 a
Diagnostic Coverage (DC)	0 %

Indicators/operating means

Function indicator	LED yellow: lights when object is detected
Control elements	Sensing range adjuster
Control elements	Adjuster for switch-off delay and switch-on delay

Electrical specifications

Operating voltage	U _B	24 V DC -5% / +10%
Ripple		max. 10 %
No-load supply current	I ₀	max. 115 mA

Output

Switching type	light on	
Signal output	1 PNP, short-circuit protected, reverse polarity protected	
Switching voltage	max. 30 V DC	
Switching current	max. 200 mA	
Switching frequency	f	100 Hz
Response time	5 ms	
On-delay	0 ... 2000 ms	
Off-delay	0 ... 2000 ms	
Pneumatic output	3/2 way valve	
Type of valve	currentless closed	
Operating pressure	0 ... 7 bar (0 ... 101.5 psi)	
Medium	air	

Conformity

Product standard	EN 60947-5-2
------------------	--------------

Ambient conditions

Ambient temperature	-15 ... 50 °C (5 ... 122 °F)
Storage temperature	-30 ... 60 °C (-22 ... 140 °F)

Mechanical specifications

Housing width	18 mm
Housing height	100 mm
Housing depth	46 mm
Degree of protection	IP65
Connection	4-pin, M12 x 1 connector ; Connecting cable with Socket, straight M12 x 1 ; Length: 1200 mm

Material

Housing	plastic
Optical face	plastic lens
Mass	approx. 200 g

Compliance with standards and directives

Standard conformity	
Shock and impact resistance	IEC / EN 60068. half-sine, 40 g in each X, Y and Z directions
Vibration resistance	IEC / EN 60068-2-6. Sinus. 10 -1000 Hz, 10 g in each X, Y and Z directions

Approvals and certificates

UL approval	cULus Listed, Class 2 Power Source, Type 1 enclosure
CCC approval	CCC approval / marking not required for products rated ≤36 V

Accessories**OMH-SBL-01**

Mounting bracket for sensors of SBL series

V1-G-2M-PVC

Female cordset, M12, 4-pin, PVC cable

V1-G-5M-PVC

Female cordset, M12, 4-pin, PVC cable

V1-W-2M-PUR

Female cordset, M12, 4-pin, PUR cable

V1-W-5M-PUR

Female cordset, M12, 4-pin, PUR cable

V1S-TEE-V1/V1S

T-Distributor, M12 connector to M12 socket/connector

Schraubendreher 0,5 x 3,0 mm

Screwdriver

Additional accessories can be found in the Internet.

Curves/Diagrams

Difference in detection distance

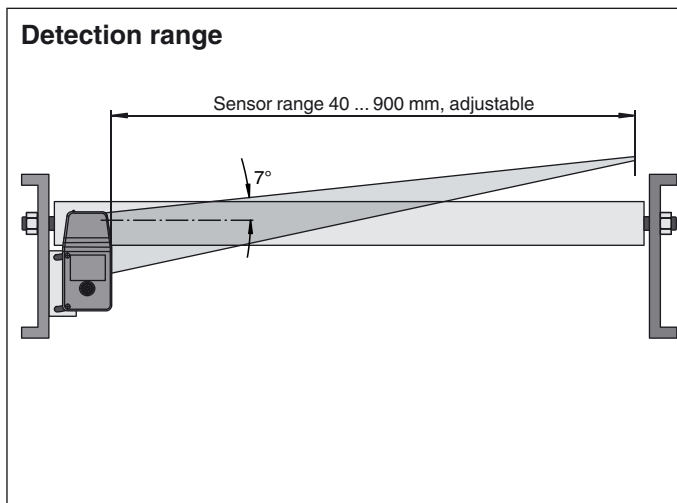
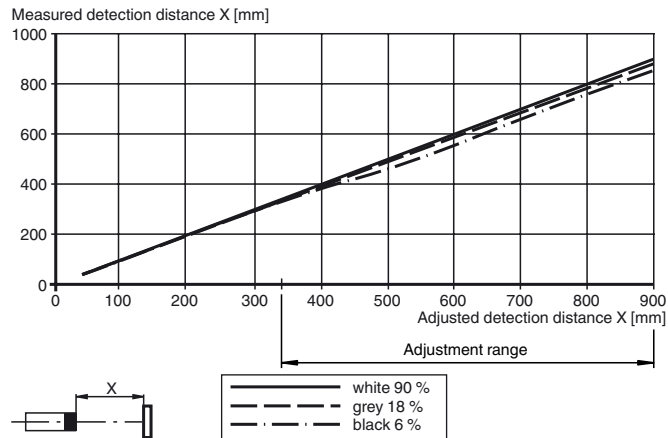

Options:

Sensors with the **version -V** are equipped with a solenoid valve and can directly control a 3/2 way pneumatic actuator, without any-interaction of an external system controlling unit (PLC). As soon as conveyed goods are detected, the diffuse mode sensor gives an electrical-signal to the pneumatic solenoid valve, which is then activated.

Sensors with the control logic **option -SL-(V)** allows up to 50 diffuse mode sensors to be connected-to each other (data and power), depending on the current consumption of sensor and solenoid valve. An additional supply power and data bus cable is used to interconnect the sensors with control logic option -SL. All necessary functions for controlling the material flow of conveyed goods are supported, such as: single feed, single release, slug release, external motor and solenoid valve control. It is also possible to energize the valves of all sensors included in the cascade by slug release (VT). To do this, apply the positive supply voltage (+UB) on the input VT of the first sensor.

Sensors with timing **function -Z** features the adjustment of the ON- and OFF delay of the output independently. This optimizes control of the solenoid valve. A zero pressure accumulation of the conveyed goods can be realized with application of time ON- and OFF delay of the output. The ON- and OFF delay to control the switching of the solenoid valve may be adjusted between 0 and 2 seconds.

Additional power supply between every 20 to 25 sensors can be realized by the use of the power in feed junction V1S-TEE-V1/V1S in combination with a cable V1-G-...-PVC. This features to practically connect any number of SBL sensors in series. Attention should be paid to the maximum rated current of the cable and the connectors which usually is max. I = 4 A. For more details on the maximum rated current of single components, please refer to our datasheet values. For the electrical supply of the sensors the country specific standards have to be considered.

Note:

Use a screwdriver to adjust the sensing range. We strongly recommend to use the screwdriver given in the accessories section.