

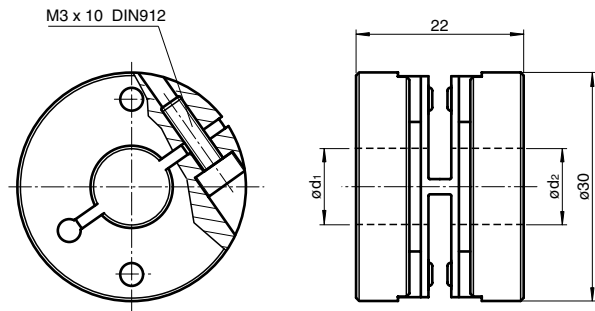

Dimensions



Model Number

9404 12*12

Spring disk coupling

Features

- Very high torsion spring stiffness
- Suitable up to 12.000 rpm
- Well misalignment compensation
- Vibration- isolating
- Electrically insulating

Technical data

Mechanical specifications

Shaft diameter	d1 = 12 mm , d2 = 12 mm
Material	
Flange	aluminum
Spring washers	plastic
Mass	approx. 28 g
Rotational speed	max. 12000 min ⁻¹
Max. torque	0.6 Nm
Radial offset	max. ± 0.3 mm
Axial offset	max. ± 0.4 mm
Angle error	max. ± 2.5 °
Torsional rigidity	50 Nm / rad
Mounting	clamping flange