



Model Number

CVS78E

Features

- Up to 16 Bit singleturn
- ATEX approval
- IECEx approval
- Flameproof enclosure
- Removable connection cap

Description

Absolute encoders deliver an absolute step value for each angle setting. All these values are represented by code samples on one or more code disks which are sampled by a photoelectric array. The absolute encoder has a maximum basic resolution of 65536 steps per revolution (16 Bits). The encoders integrated CAN bus interface supports all CANopen functions. The following operating modes can be programmed, and can be selectively turned on or off:

- Polled mode
- Cyclic mode
- Sync mode

The device is designed for shaft assembly and is available in servo flange or clamping flange design. The bus electronics module is integrated into the removable housing cover. This makes it possible to mount or replace the encoder and the bus electronics separately during installation or service.

Technical Data

General specifications

Detection type	photoelectric sampling
Device type	Singleturn absolute encoder

Functional safety related parameters

MTTF _d	25 a
Mission Time (T _M)	20 a
L ₁₀	7.7 E+9 at 3000 rpm
Diagnostic Coverage (DC)	0 %

Electrical specifications

Operating voltage U _B	10 ... 30 V DC
No-load supply current I ₀	max. 350 mA
Linearity	± 2 LSB at 16 Bit, ± 1 LSB at 13 Bit, ± 0,5 LSB at 12 Bit
Output code	binary code
Code course (counting direction)	cw ascending (clockwise rotation, code course ascending) cw descending (clockwise rotation, code course descending)

Interface

Interface type	CANopen
Resolution	
Single turn	up to 16 Bit
Overall resolution	up to 16 Bit
Transfer rate	max. 1 MBit/s
Standard conformity	communication profile: DS 301 Device profiles: DS 406 and DS 417, programmable according to class 2

Connection

Cable	Ø 10.2 mm, Radox 9 x 0.5 mm ²
Terminal compartment	see ordering information

Standard conformity

Degree of protection	DIN EN 60529, IP66
Climatic testing	DIN EN 60068-2-3, no moisture condensation
Emitted interference	EN 61000-6-4:2007
Noise immunity	EN 61000-6-2:2005
Shock resistance	DIN EN 60068-2-27, 100 g, 3 ms
Vibration resistance	DIN EN 60068-2-6, 10 g, 10 ... 2000 Hz

Ambient conditions

Operating temperature	-40 ... 70 °C (-40 ... 158 °F)
Storage temperature	-40 ... 85 °C (-40 ... 185 °F)

Mechanical specifications

Material	
Combination 1	housing: anodized aluminum flange: anodized aluminum shaft: Stainless steel 1.4401 / AISI 316
Combination 2 (Inox)	housing: stainless steel 1.4404 / AISI 316L flange: stainless steel 1.4404 / AISI 316L shaft: Stainless steel 1.4401 / AISI 316
Mass	approx. 2600 g (combination 1) approx. 3900 g (combination 2)
Rotational speed	max. 3000 min ⁻¹
Moment of inertia	180 gcm ²
Starting torque	≤ 4 Ncm
Shaft load	
Axial	60 N
Radial	80 N

Data for application in connection with hazardous areas

EU-type examination certificate	ITS 15 ATEX 18372X IECEx ITS 15.0061X
Marking	⊕ II 2G Ex d IIC T5 Gb ⊕ II 2D Ex tb IIIC T100°C Db
Directive conformity	
Directive 2014/34/EU	IEC 60079-0:2011, EN 60079-0:2012+A11:2013, IEC 60079-1:2014, EN 60079-1:2014, IEC 60079-31:2013, EN 60079-31:2014

Dimensions

Encoder length L

Version		Length L
Radial cable exit	Clamping flange	109 mm
	Servo flange	109 mm
Axial cable exit	Clamping flange	125 mm
	Servo flange	125 mm

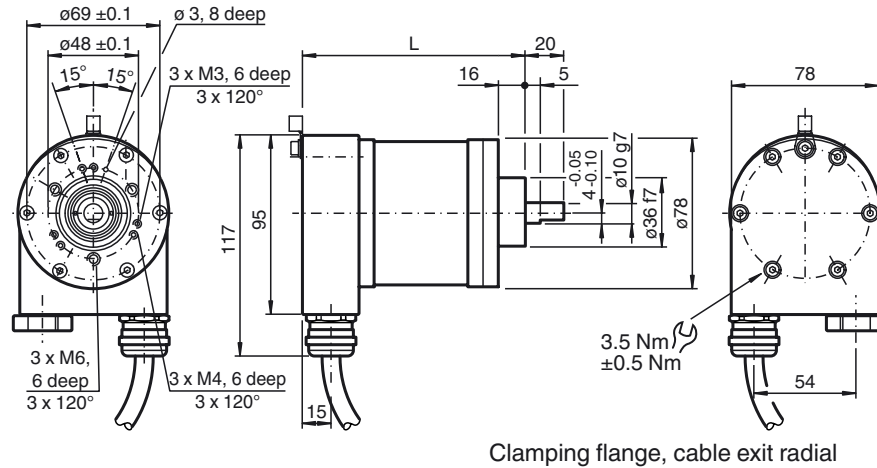

Clamping flange, cable exit radial

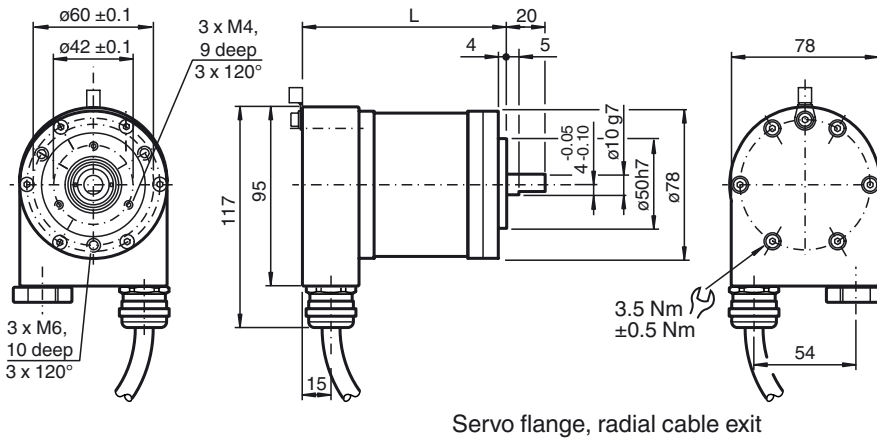

Servo flange, radial cable exit

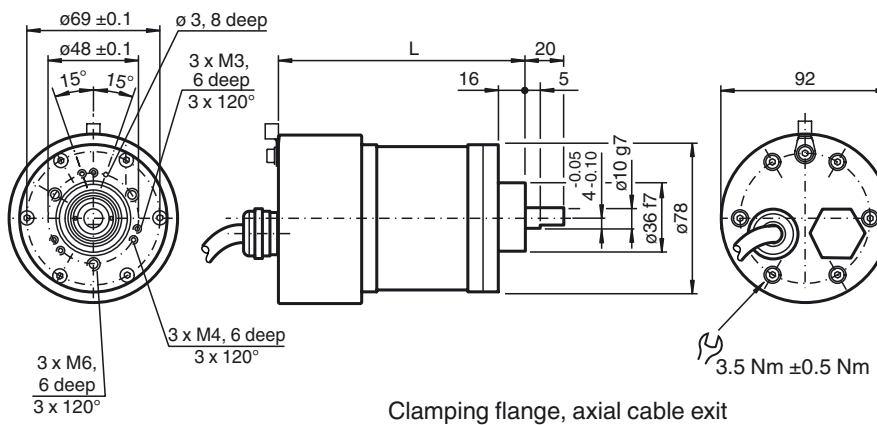

Clamping flange, axial cable exit

Release date: 2019-08-23 11:33 Date of issue: 2019-08-23 11:33 1160344_eng.xml

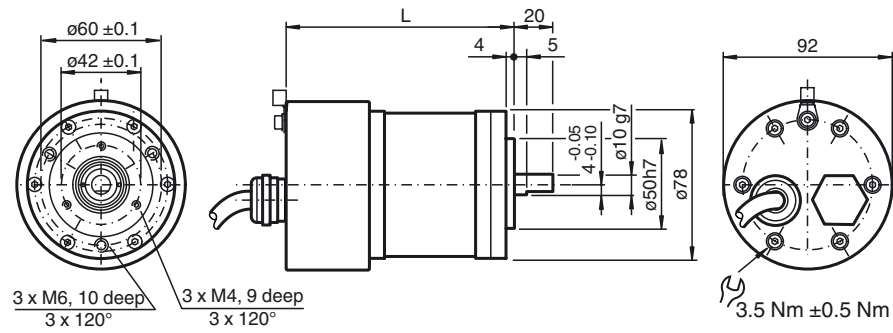

Servo flange, axial cable exit

Shaft 12 mm

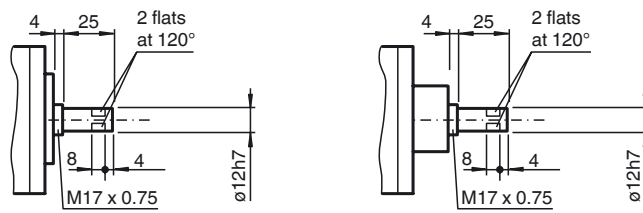

Electrical connection

Terminal	Cable	Explanation
(-)	1	- Power supply
(+)	2	+ Power supply
L	3	CAN low
H	4	CAN high
G	5	CAN ground
L	6	CAN low
H	7	CAN high
G	8	CAN ground
⊥	green / yellow	Ground connection of encoder housing

Release date: 2019-08-23 11:33 Date of issue: 2019-08-23 11:33 1160344_eng.xml

Indicating and operating elements

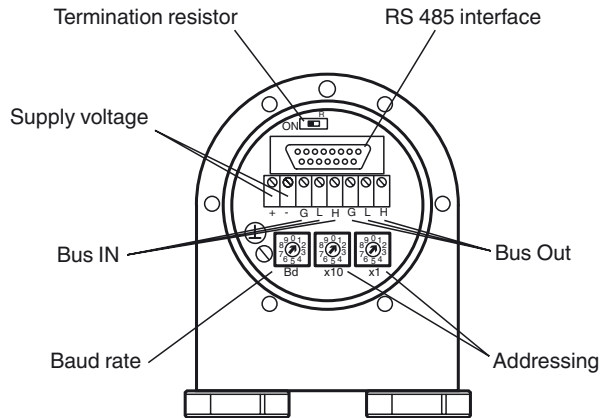

Adjusting the participant address

The participant address can be adjusted with the rotary switches. The address can be defined between 1 and 96, and may only be assigned once. The addresses 97 ... 99 are reserved.

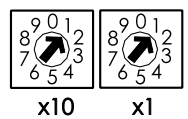

Adjusting the termination resistor

The terminating resistor R_T (121 Ω) can be connected to the circuit by means of the switch:



Baud rate adjustment

Baud rate [kBit/s]	Switch position	Baud rate [kBit/s]	Switch position
20	0	500	5
50	1	800	6
100	2	1000	7
125	3	reserved	8
250	4	set baud rate by SDO message and LSS	9

Release date: 2019-08-23 11:33 Date of issue: 2019-08-23 11:33 t160344_eng.xml

Programmable CAN operating modes

Mode	Explanation
Polled mode	The connected host requests the current actual position value via a remote transmission request telegram. The absolute encoder reads in the current position, calculates all parameters that have been set and sends back the process actual value through the same CAN identifier.
Cyclic mode	The absolute encoder sends the current actual process value cyclically, without being prompted by the host. The cycle time can be programmed in milliseconds for values between 1 ms and 65536 ms.
Sync mode	After the sync telegram has been received by the host, the absolute encoder sends the current actual process value. If multiple nodes should respond to the sync telegram, the individual nodes report one after the other according to their CAN identifier. There is no programming of an offset time. The sync counter can be programmed so that the rotary encoder does not transmit until after a defined number of sync telegrams.

Programmable rotary encoder parameters

Parameter	Explanation
Operating parameter	The direction of rotation (complement) can be specified by parameter as the operating parameter. This parameter determines the direction of rotation in which the output code will ascend or descend.
Resolution per revolution	The "Resolution" parameter is used to program the rotary encoder so that a desired number of steps can be implemented in reference to one revolution.
Preset value	The preset value is the desired position value that must be achieved for a specific physical setting of the axis. The preset value parameter is used to set the actual position value to the desired actual process value.
2 limit switches	A total of two positions can be programmed. The absolute encoder sets one bit to high state in the 32 Bit actual process value if a value falls outside the range between these two positions.
8 cam switches	Up to 8 position values can be programmed as cams. By reaching these values bits in object 6300h Cam state register are set.

