



### Model Number

NBN4-F25K-2Z4L

### Features

- Direct mounting on standard actuators
- Small construction with sturdy plastic housing of protection class IP 67
- 2-wire DC sensor with minimum off-state current
- Plug-in terminals

### Accessories

#### BT32

Activator for F25 series

#### BT33

Activator for F25 series

#### BT34

Activator for F25 series

#### BT32XAS

Activator for F25 series

#### BT43-RG-01

Activator for F25 series including protective housing and mounting plate

## Technical Data

### General specifications

Switching function		2 x normally open (NO)
Output type		Two-wire
Rated operating distance	$s_n$	4 mm
Installation		flush mountable
Output polarity		DC
Assured operating distance	$s_a$	0 ... 3.24 mm
Actual operating distance	$s_r$	3.6 ... 4.4 mm typ.
Reduction factor $r_{Al}$		0.6
Reduction factor $r_{Cu}$		0.45
Reduction factor $r_{304}$		1
Reduction factor $r_{St37}$		1.2
Output type		2x 2-wire

### Nominal ratings

Operating voltage	$U_B$	5 ... 30 V DC
Switching frequency	$f$	0 ... 500 Hz
Hysteresis	$H$	typ. 5 %
Reverse polarity protection		reverse polarity protected
Short-circuit protection		pulsing
Voltage drop	$U_d$	$\leq 4.5$ V
Design data		
Operating current	$I_L$	4 ... 100 mA
Off-state current	$I_r$	120 ... 200 $\mu$ A typ. 175 $\mu$ A at 25 °C
Time delay before availability	$t_v$	$\leq 100$ ms
Switching state indicator		LED, yellow

### Ambient conditions

Ambient temperature	-25 ... 70 °C (-13 ... 158 °F)
Storage temperature	-40 ... 85 °C (-40 ... 185 °F)

### Mechanical specifications

Connection (system side)	screw terminal , M20 x 1.5 cable gland
Housing material	PBT
Sensing face	PC
Degree of protection	IP67
Mass	98 g
Tightening torque, fastening screws	M5 x 25 : 2.7 Nm
Note	Mounted on mechanical drive

### Compliance with standards and directives

Standard conformity	
Standards	EN 60947-5-2:2007 EN 60947-5-2/A1:2012 IEC 60947-5-2:2007 IEC 60947-5-2 AMD 1:2012

### Approvals and certificates

UL approval	cULus Listed
CCC approval	CCC approval / marking not required for products rated $\leq 36$ V

Dimensions

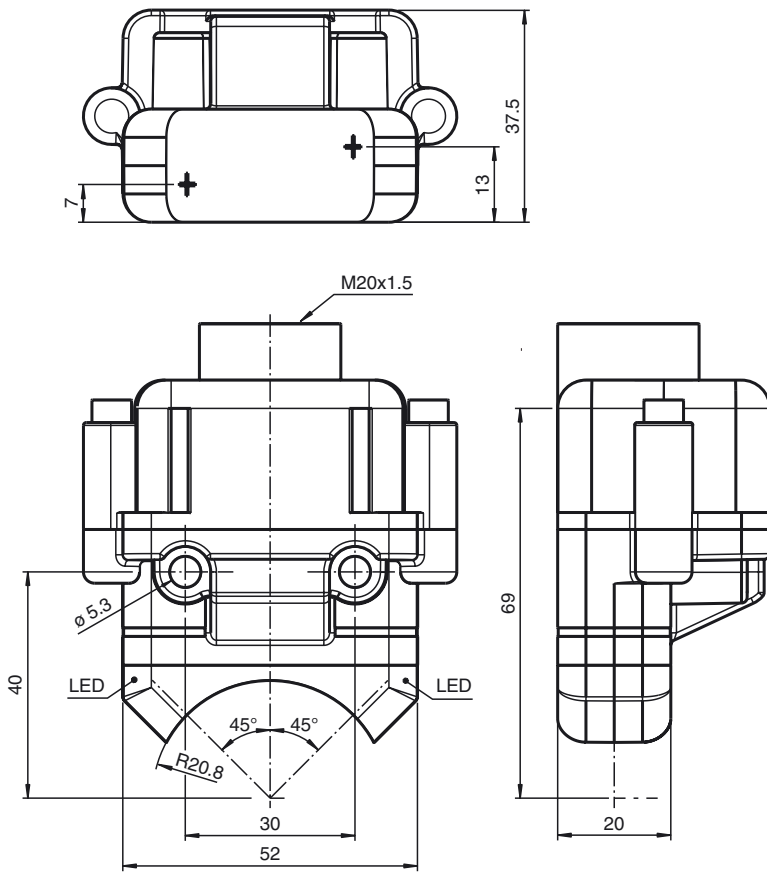

Electrical Connection

