



**Model Number**

**UC2000-L2M-I-T-2M**

Single head system

**Features**

- Extended temperature range
- Cable connection
- Rugged metal base
- Sensor head bidirectional and rotatable
- Function indicators visible from all directions
- Selectable sound lobe width
- Programmable

**Diagrams**

**Characteristic response curve**

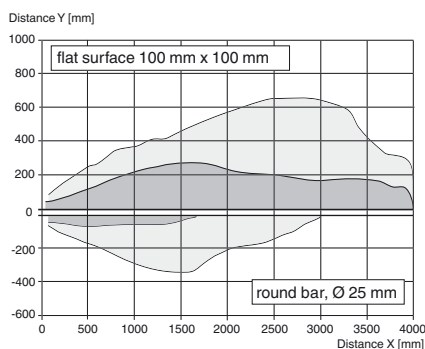

**Technical data**

**General specifications**

Sensing range	60 ... 2000 mm
Adjustment range	80 ... 2000 mm
Dead band	0 ... 60 mm
Standard target plate	100 mm x 100 mm
Transducer frequency	approx. 175 kHz
Response delay	minimum : 60 ms factory setting: 330 ms

**Indicators/operating means**

LED green	Operating display
LED yellow	object in evaluation range
LED red	error

**Electrical specifications**

Operating voltage $U_B$	10 ... 30 V DC , ripple 10 % <sub>SS</sub>
No-load supply current $I_0$	≤ 50 mA

**Interface**

Interface type	Serial interface (programming adapter required) 9600 BPS, no parity, 8 data bits, 1 stop bit
----------------	---

**Input/Output**

Input/output type	1 synchronization connection, bidirectional
0 Level	0 ... 1 V
1 Level	4 V ... $U_B$
Input impedance	> 12 k $\Omega$
Output rated operating current	< 12 mA
Pulse length	0.5 ... 300 ms (level 1)
Pulse interval	≥ 33 ms (level 0)
Synchronization frequency	
Common mode operation	≤ 30 Hz
Multiplex operation	≤ 33 Hz / n , n = number of sensors , n ≤ 10 (factory setting: n = 5 )

**Input**

Input type	1 program input
Level (evaluation limit 1)	0 ... 1 V
Level (evaluation limit 2)	4 V ... $U_B$
Input impedance	> 12 k $\Omega$
Pulse length	2 ... 10 s

**Output**

Output type	1 analog output 4 ... 20 mA
Resolution	Evaluation range [mm]/3200, however ≥ 0.4 mm
Deviation of the characteristic curve	≤ 0.2 % of full-scale value
Repeat accuracy	≤ 0.1 % of full-scale value
Load impedance	≤ 500 $\Omega$ at $U_B$ ≥ 14V ≤ 300 $\Omega$ at $U_B$ < 14V
Temperature influence	≤ 1.5 % of full-scale value

**Ambient conditions**

Ambient temperature	-40 ... 70 °C (-40 ... 158 °F)
Storage temperature	-40 ... 85 °C (-40 ... 185 °F)

**Mechanical specifications**

Connection type	cable , 5-pin
Degree of protection	IP67
Material	
Housing	PA-GF35
Cable	PUR
Transducer	epoxy resin/hollow glass sphere mixture; polyurethane foam
Cable	
Sheath diameter	7.25 mm
Bending radius	> 37.3 mm , fixed > 74.7 mm , moving
Core cross-section	5 x 0.82 mm <sup>2</sup>
Length L	2 m
Mass	345 g

**Factory settings**

Output	near limit: 80 mm far limit: 2000 mm Output mode: rising ramp
Beam width	wide
Evaluation procedure	low-pass behavior

**General information**

Supplementary information	Switch settings of the external programming adapter: "output load": pull-down "output logic": noninv
---------------------------	--

**Compliance with standards and directives**

Standard conformity	
Standards	EN 60947-5-2:2007+A1:2012 IEC 60947-5-2:2007 + A1:2012 EN 60947-5-7:2003 IEC 60947-5-7:2003

**Approvals and certificates**

EAC conformity	TR CU 020/2011
UL approval	cULus Listed, General Purpose
CCC approval	CCC approval / marking not required for products rated ≤36 V

Release date: 2019-10-25 07:53 Date of issue: 2019-10-25 299137\_eng.xml

**Dimensions**

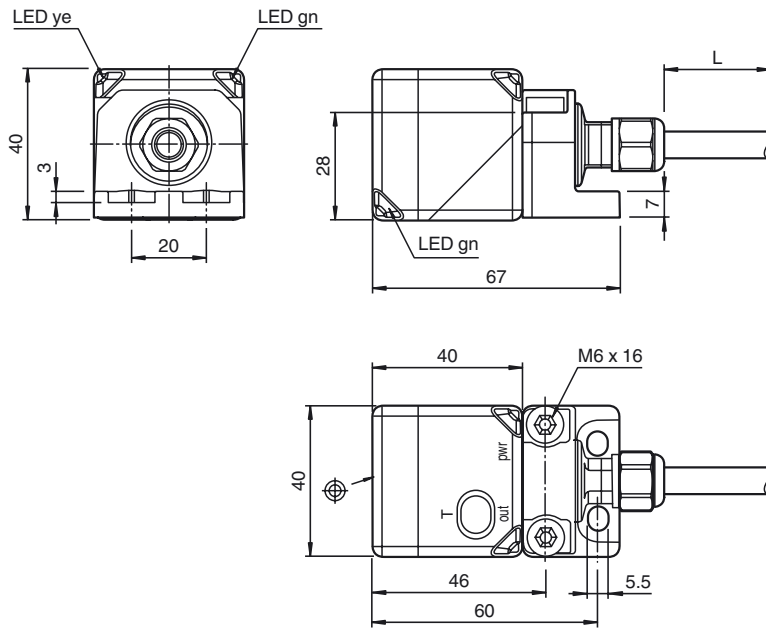

**Additional Information**

**Analog output modes**

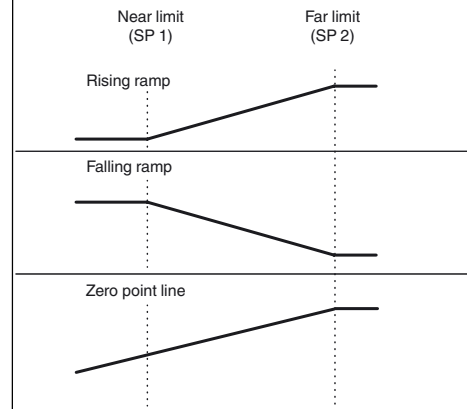

**Electrical Connection**

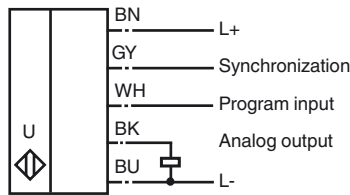

Wire colors in accordance with EN 60947-5-2

1	BN	(brown)
2	WH	(white)
3	BU	(blue)
4	BK	(black)
5	GY	(gray)

**Accessories**

**UC-PROG1-USB**

Programming adapter

**V15S-G-0,3M-PUR-WAGO**

Male cordset, M12, 5-pin, PUR cable with WAGO terminals

**Description of Sensor Functions**

**Adjustment possibilities**

The sensor is equipped with 1 analog output with 2 programmable limits. The programming of the limits, the output mode and the beam width can be done in 3 different ways:

- Using the teach input of the sensor
- By means of the sensor's programming button
- Using the sensor's serial interface. This method requires an external programming adapter and the corresponding software. You will find the download link for the software at [www.pepperl-fuchs.com](http://www.pepperl-fuchs.com) on the product page of the sensor.

**Synchronization**

Refer to "General Notes Relating to Pepperl+Fuchs Product Information".

Pepperl+Fuchs Group  
www.pepperl-fuchs.com

USA: +1 330 486 0001  
fa-info@us.pepperl-fuchs.com

Germany: +49 621 776 1111  
fa-info@de.pepperl-fuchs.com

Singapore: +65 6779 9091  
fa-info@sg.pepperl-fuchs.com

The sensor features a synchronization input for suppressing ultrasonic mutual interference ("crosstalk"). The following synchronization modes are available:

1. Automatic multiplex mode
2. Automatic master slave common mode
3. Externally controlled synchronization

### Further Documentation

For information on programming via programming button and synchronisation you may refer to the commissioning instruction.

Release date: 2019-10-25 07:53 Date of issue: 2019-10-25 299137\_eng.xml

Refer to "General Notes Relating to Pepperl+Fuchs Product Information".

Pepperl+Fuchs Group  
www.pepperl-fuchs.com

USA: +1 330 486 0001  
fa-info@us.pepperl-fuchs.com

Germany: +49 621 776 1111  
fa-info@de.pepperl-fuchs.com

Singapore: +65 6779 9091  
fa-info@sg.pepperl-fuchs.com

 **PEPPERL+FUCHS**