

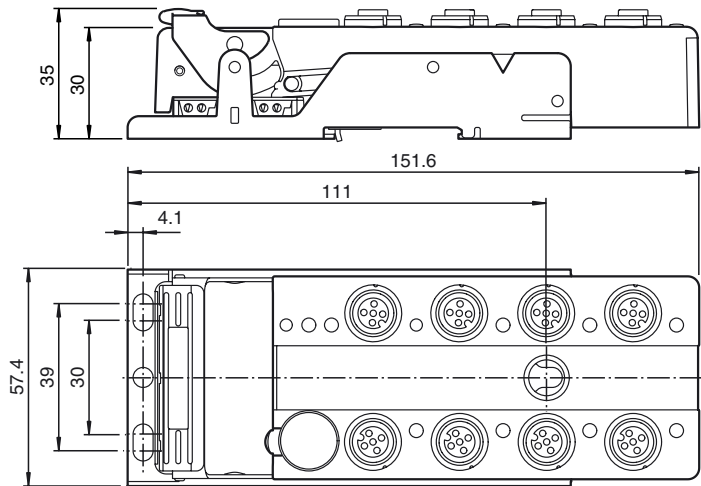

Dimensions

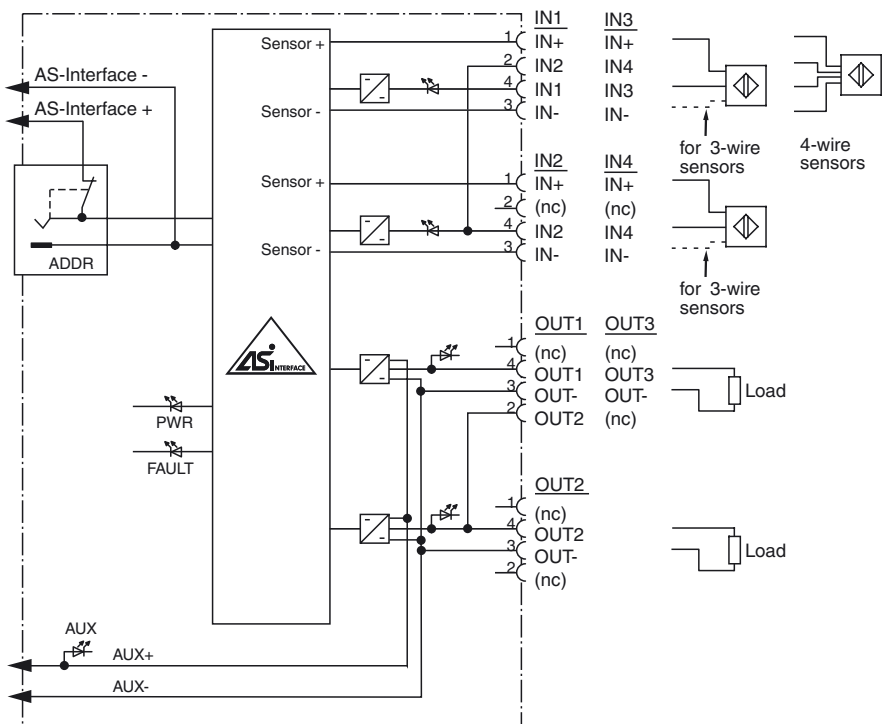

Electrical connection



Model number

VBA-4E3A-G12-ZAJ/EA2L

G12 flat module
4 inputs (PNP) and 3 electronic outputs

Features

- A/B slave with extended addressing possibility for up to 62 slaves
- One-piece housing with stainless steel base
- Installation without tools
- Metal threaded inserts with SPEED-CON technology
- Flat cable connection with cable piercing technique, variable flat cable guide
- Red LED per channel, lights up in the event of output overload
- Communication monitoring, configurable
- Inputs for 2-, 3-, and 4-wire sensors
- DIN rail mounting
- AS-Interface certificate

Indicating / Operating means

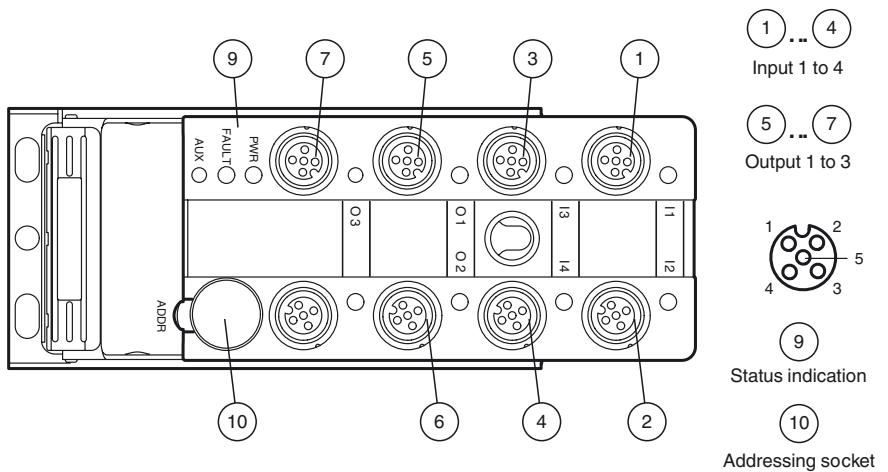

Technical data

Release date: 2020-02-06 11:42 Date of issue: 2020-02-06 201888_eng.xml

Refer to "General Notes Relating to Pepperl+Fuchs Product Information".

Pepperl+Fuchs Group
www.pepperl-fuchs.com

USA: +1 330 486 0001
fa-info@us.pepperl-fuchs.com

Germany: +49 621 776 4411
fa-info@de.pepperl-fuchs.com

Singapore: +65 6779 9091
fa-info@sg.pepperl-fuchs.com

General specifications

Slave type	A/B slave
AS-Interface specification	V3.0
Required master specification	≥ V2.1
UL File Number	E223772

Functional safety related parameters

MTTF _d	200 a
Mission Time (T _M)	20 a
Diagnostic Coverage (DC)	0 %

Indicators/operating means

LED FAULT	error display; LED red red: communication error or address is 0 red flashing: overload of sensor power supply or outputs
LED PWR	AS-Interface voltage; green LED green: voltage OK flashing green: address 0
LED AUX	ext. auxiliary voltage U _{AUX} ; dual LED green/red green: voltage OK red: reverse voltage
LED IN	switching state (input); 4 LED yellow
LED OUT	Switching status (output); 3 yellow/red LEDs Yellow: output active Red: output overload

Electrical specifications

Auxiliary voltage (output)	U _{AUX}	24 V DC ± 15 % PELV
Rated operating voltage	U _e	26.5 ... 31.6 V from AS-Interface
Rated operating current	I _e	≤ 40 mA (without sensors) / max. 240 mA
Protection class		III
Surge protection		U _{AUX} , U _{in} : Over voltage category III, safe isolated power supplies (PELV) derived from mains up to 300 V AC line-to-neutral

Input

Number/Type	4 inputs for 2- or 3-wire sensors (PNP), DC option 2 inputs for 4-wire sensors (PNP), DC
Supply	from AS-Interface
Voltage	21 ... 31 V
Current loading capacity	≤ 200 mA, overload and short-circuit protected
Input current	≤ 8 mA (limited internally)
Switching point	according to DIN EN 61131-2 (Type 2)
0 (unattenuated)	≤ 2 mA
1 (attenuated)	≥ 6 mA
Signal delay	< 1 ms (input/AS-Interface)

Output

Number/Type	3 electronic outputs, PNP, overload and short-circuit proof
Supply	from external auxiliary voltage U _{AUX}
Voltage	≥ (U _{AUX} - 0.5 V)
Current	2 A per output 6 A total (TB ≤ 40 °C) 4 A total (TB ≤ 70 °C)

Directive conformity

Electromagnetic compatibility	
Directive 2014/30/EU	EN 62026-2:2013

Standard conformity

Degree of protection	EN 60529:2000
Fieldbus standard	EN 62026-2:2013
Input	EN 61131-2
Emitted interference	EN 61000-6-4:2007
AS-Interface	EN 62026-2:2013
Noise immunity	EN 61000-6-2:2005 EN 62026-2:2013

Programming instructions

Profile	S-7.A.2
IO code	7
ID code	A
ID1 code	7
ID2 code	2

Data bits (function via AS-Interface)	input	output
D0	IN1	OUT1
D1	IN2	OUT2
D2	IN3	OUT3
D3	IN4	-

Parameter bits (programmable via AS-i) function

P0	communication monitoring P0 = 1 (default settings), monitoring = ON, i.e. if communication fails, the outputs are de-energised P0 = 0, monitoring = OFF, if communication fails, the outputs maintain their condition
P1	Input filter P1 = 0 input filter on, pulse suppression ≤ 2 ms P1 = 1 input filter off (default settings)
P2	Synchronous mode P2 = 0 synchronous mode on P2 = 1 synchronous mode off (default settings)
P3	not used

Ambient conditions

Ambient temperature	-25 ... 70 °C (-13 ... 158 °F)
Storage temperature	-25 ... 85 °C (-13 ... 185 °F)
Relative humidity	85 % , noncondensing
Climatic conditions	For indoor use only
Altitude	≤ 2000 m above MSL

Function

The VBA-4E3A-G12-ZA/EA2L is an AS-Interface trigger module with 4 inputs and 3 outputs. 2- and 3-wire sensors as well as mechanical contacts can be connected to the plus switching electronic inputs. The outputs are electronic outputs which can be energized with max. 24 V DC and 2 A per output.

The solid housing permits fast mounting without tools as well as easy removal without tools. The stainless steel shell and the cast housing ensure durability and a high protection category.

The connection to the AS-Interface cable and to the external power supply is achieved via penetration technology in the integrated flat cable. The insert for the flat cables can be turned in two orientations.

All connections to inputs and outputs are implemented via metal inserts for high stability. The connection to the sensors/actuators is achieved via a M12 x 1 circular connector with SPEEDCON quick locking option.

The inputs and the connected sensors are supplied from the internal power supply of the module (from AS-Interface), the outputs and the connected actuators via an external power source (AUX).

To indicate the current switching state there is an LED for each channel fitted to the top of the module. The outputs are protected against overload and short circuit, an output overload is indicated via an LED per channel.

An LED to indicate the AS-Interface voltage and that the module has an address of 0 is available, another indicates errors in the AS-Interface communication as well as periphery faults. Another LED indicates the external power supply (AUX).

This module can be mounted in any position using three screws or can be snapped onto the DIN rail using the stainless steel holder.

An output overload is reported to the AS-Interface master via the function "periphery fault". The communication with the AS-Interface remains intact.

Accessories**VBP-HH1-V3.0-KIT**

AS-Interface Handheld with accessory

VAZ-V1-B3

Blind plug for M12 sockets

VBP-HH1-V3.0

AS-Interface Handheld

VAZ-PK-1,5M-V1-G

Adapter cable module/hand-held programming device

VAZ-CLIP-G12

lock for G12 module

Shock and impact resistance	30 g, 11 ms in 6 spatial directions 3 shocks 10 g, 16 ms in 6 spatial directions 1000 shocks
Vibration resistance	0.75 mm 10 ... 57 Hz , 5 g 57 ... 150 Hz, 20 cycles
Pollution degree	3
Mechanical specifications	
Degree of protection	IP67
Connection	Cable piercing method flat cable yellow/flat cable black inputs/outputs: M12 round connector
Material	
Housing	PBT
Mass	230 g
Tightening torque, cable gland	0.4 Nm
Mounting	Mounting plate

Notes

For 4-wire sensors, it is only possible to use plug-in slot IN1 or IN3 for inputs 1+2 or 3+4 (jumped internally).

Do not connect inputs and outputs, which are supplied via the module from AS-interface or via auxiliary power, with power supply and signal circuits with external potentials.