



Model Number

CBX500

Connector box for barcode scanner

Features

- Connect up to 32 scanners to a network with ID-Net™
- Option of upgrading with Profibus, Ethernet and DeviceNet module as well as memory module
- Easy scanner connection by means of clamp terminals
- Degree of protection IP65

Function

Devices from the CBX* series enable barcode scanners to be connected quickly and easily. A wide variety of connections also allows other field devices to be connected. By reducing installation time and the number of system failures when a device is replaced, your operating costs will be significantly lower.

Standardized pinning of connections and simple attachment of cable ends using spring terminals ensures easy cable installation.

The configuration of the connected scanner can be saved in backup modules and restored at a later date.

To facilitate installation of the device, the continuous mounting holes are easy to access and the top section of housing can be removed.

Technical Data

Indicators/operating means

Display elements	5 LEDs (POWER, TRIGGER, IN 2, OUT 1, OUT 2)
------------------	---

Electrical specifications

Operating voltage	U_B	10 ... 30 V DC PELV
Current consumption		max. 2.5 A
Power consumption	P_0	max. 3 W

Interface

Interface type	Modular upgrade option (e.g. PROFIBUS, Ethernet, DeviceNet)
----------------	---

Ambient conditions

Ambient temperature	0 ... 50 °C (32 ... 122 °F)
Storage temperature	-20 ... 70 °C (-4 ... 158 °F)
Relative humidity	90 % , noncondensing
Shock resistance	30G ; 11 ms ; 3 impacts on each axis
Vibration resistance	1.5 mm ; 10 ... 55 Hz ; 2 hours on each axis

Mechanical specifications

Degree of protection	IP65
Connection	25-pin Sub-D socket for Barcode scanner , M16 cable gland for system connection (5x)

Material

Housing	PC (Polycarbonate)
Mass	780 g

Compliance with standards and directives

Directive conformity	89/336 EWG
Standard conformity	
Noise immunity	EN 61000-6-2
Degree of protection	EN 60529
Shock and impact resistance	EN 60068-2-27
Vibration resistance	EN 60068-2-6

Dimensions

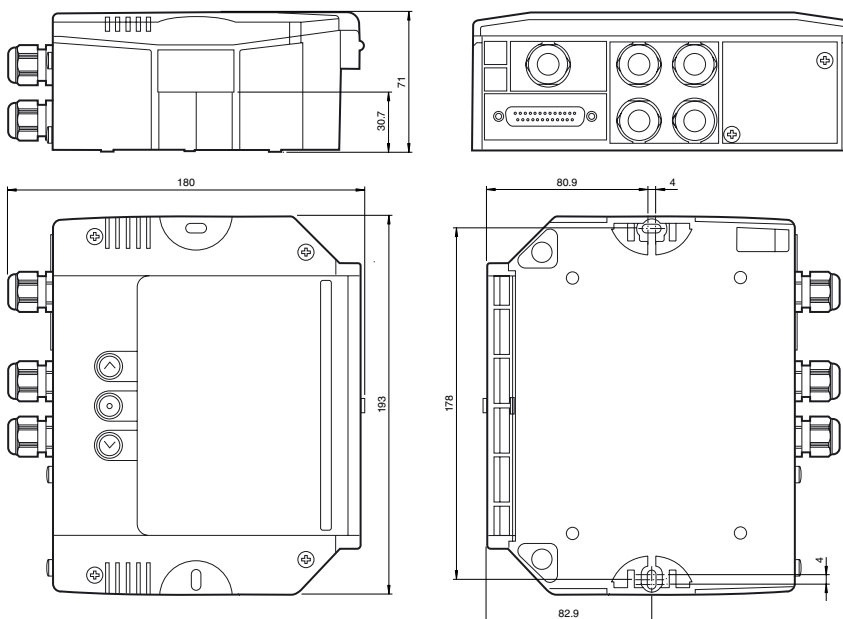

Electrical connection

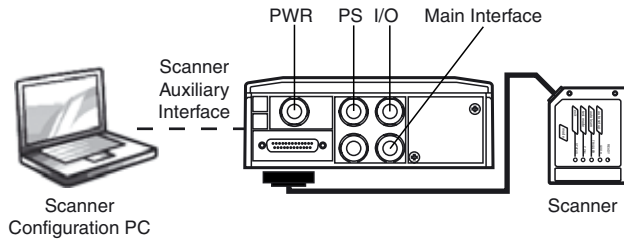

Electrical connection

Inside View

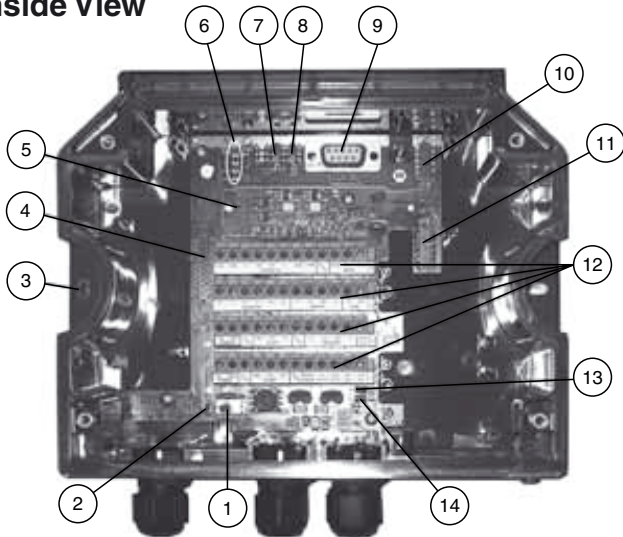

- | | |
|--|---|
| ① Power switch (on/off) | ⑧ ID-NET Terminator Switch |
| ② Adjustment of Chassis grounding via Jumper | ⑨ Serial Interface (SUB-D, 9-pin) |
| ③ Mounting Holes (2x) | ⑩ IP65 Fieldbus Module Connector |
| ④ Remote I/O Extension Module Connector | ⑪ Standard Fieldbus Module Connector |
| ⑤ Backup Module Connector | ⑫ Terminal Block |
| ⑥ LEDs | ⑬ Adjustment of Shield to Protection Earth via Jumper |
| ⑦ RS485 Terminator Switch | ⑭ External Power Source (on/off) |

Release Date: 2016-05-04 08:59 Date of issue: 2016-05-04 207508_eng.xml