



Inductive sensor NCN3-F31K2-N4-B13-S

- Direct mounting on standard actuators
- ATEX & IECEx certifications
- Usable up to SIL 2 acc. to IEC 61508
- Weatherproof housing for outdoor applications
- LEDs for switching state of sensor and solenoid valve
- Plug-in terminals
- Temperature range
-40 ... 100 °C (-40 ... 212 °F)



Dimensions

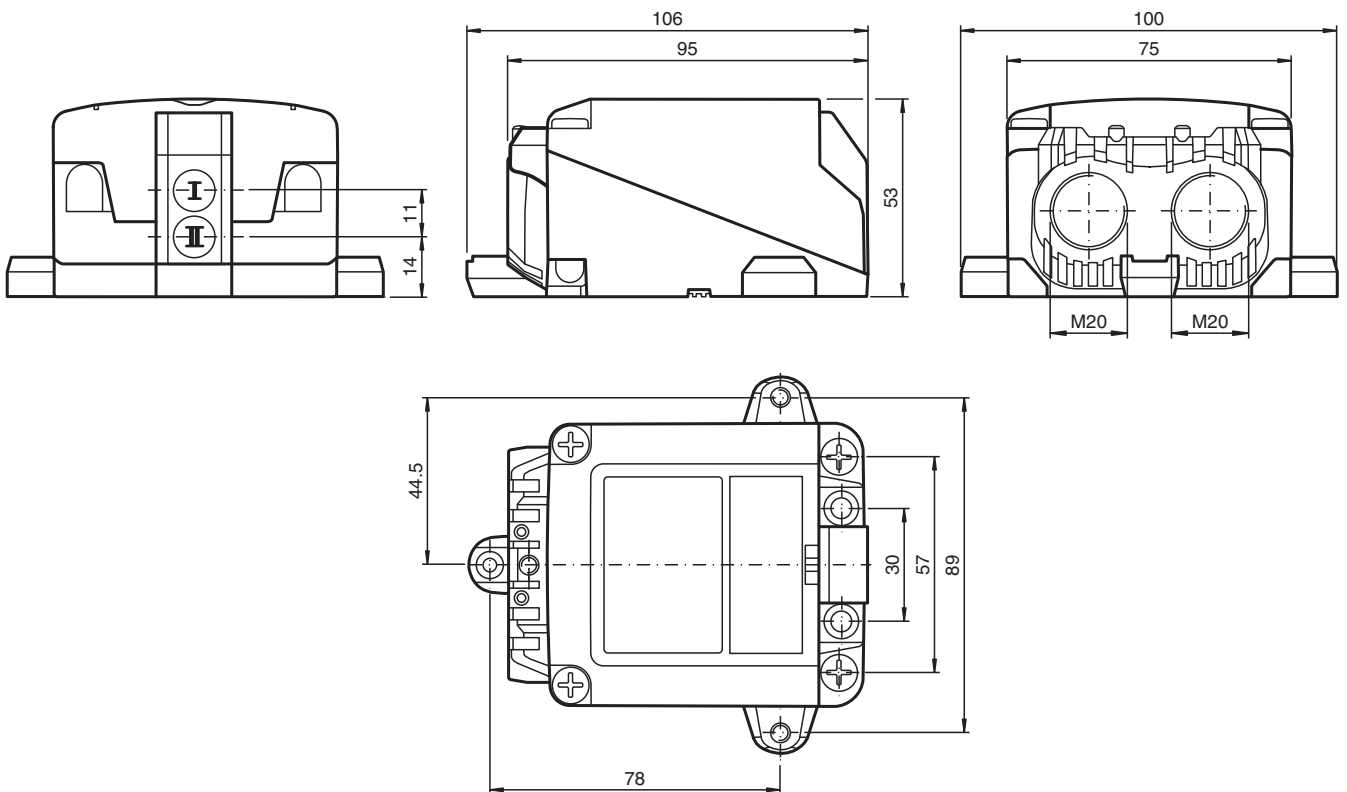

Technical Data

General specifications

Switching function 2 x normally closed (NC)

Technical Data

Output type		NAMUR
Rated operating distance	s_n	3 mm
Installation		flush mountable
Assured operating distance	s_a	0 ... 2.4 mm For assured operating distance s_{ar} see Manual Functional Safety.
Actual operating distance	s_r	2.7 ... 3.3 mm typ.
Actuating element		Stainless steel 1.4305 / AISI 303 8.5 mm x 8.5 mm x 0.5 mm
Reduction factor r_{Al}		0.4
Reduction factor r_{Cu}		0.4
Reduction factor r_{304}		0.7
Reduction factor r_{Si37}		1
Reduction factor r_{Brass}		0.5
Output type		2-wire
Nominal ratings		
Nominal voltage	U_o	8 V
Switching frequency	f	0 ... 3 kHz
Hysteresis	H	typ. 5 %
Reverse polarity protection		reverse polarity protected
Short-circuit protection		yes
Suitable for 2:1 technology		yes, Reverse polarity protection diode not required
Current consumption		
Measuring plate not detected		≥ 3 mA
Measuring plate detected		≤ 1 mA
Time delay before availability	t_v	≤ 1 ms
Switching state indicator		LED, yellow
Valve status indicator		LED, yellow
Functional safety related parameters		
Safety Integrity Level (SIL)		SIL 2
MTTF _d		1730 a
Mission Time (T_M)		20 a
Diagnostic Coverage (DC)		0 %
Valve circuit		
Voltage		max. 32 V DC
Current		max. 240 mA
Short-circuit protection		no
Reverse polarity protection		yes, with reversed output LED is out of function, therefore more power for solenoid valve
Compliance with standards and directives		
Standard conformity		
NAMUR		EN 60947-5-6:2000 IEC 60947-5-6:1999
Electromagnetic compatibility		NE 21:2007
Standards		EN 60947-5-2:2007 EN 60947-5-2/A1:2012 IEC 60947-5-2:2007 IEC 60947-5-2 AMD 1:2012
Approvals and certificates		
UL approval		cULus Listed, General Purpose, Class 2 Power Source
CCC approval		CCC approval / marking not required for products rated ≤ 36 V
Ambient conditions		
Ambient temperature		-40 ... 100 °C (-40 ... 212 °F)
Storage temperature		-40 ... 100 °C (-40 ... 212 °F)
Mechanical specifications		
Connection (system side)		Screw terminals, tightening torque min. 0.5 Nm Stripped length 7 mm, M20 x 1.5

Release date: 2020-03-25 Date of issue: 2020-03-30 Filename: 235078_eng.pdf

Technical Data

Core cross-section (system side)		rigid: 0.14 ... 2.5 mm ² flexible: 0.14 ... 1.5 mm ² flexible with core-end sleeve: 0.25 ... 1.5 mm ²
Connection (valve side)		like connection (system side)
Core cross-section (valve side)		like core cross section (system side)
Housing material		rugged, translucent polycarbonate (PC) optimised for outdoor use
Housing base		PC
Degree of protection		IP66 / IP68 / IP69
Tightening torque, housing screws		≤ 2 Nm
Tightening torque, cable gland		M20 x 1.5 ; max. 7 Nm
Tightening torque, stopping plug		1 Nm
Note		LED switch-off
Data for application in connection with hazardous areas		
Equipment protection level		Ga , Gb , Gc (ic) , Mb
Equipment protection level Ga		
Type of protection		intrinsic safety
CE marking		[*PD-Z02585A*]
Certificates		
Appropriate type		NCN3-F31K2...-N4...
ATEX certificate		TÜV 17 ATEX 8125 X
ATEX marking		Ⓜ II 1G Ex ia IIC T6...T1 Ga
Standards		EN 60079-0:2012+A11:2013 , EN 60079-11:2012
IECEX certificate		IECEX TUR 17.0055X
IECEX marking		Ex ia IIC T6...T1 Ga
Standards		IEC 60079-0:2011 , IEC 60079-11:2011
Effective internal capacitance	C _i	max. 100 nF The value is applicable for one sensor circuit. A cable length of 10 m is considered.
Effective internal inductance	L _i	max. 100 µH The value is applicable for one sensor circuit. A cable length of 10 m is considered.
Maximum permissible ambient temperature	T _{amb}	Also observe the maximum permissible ambient temperature stated in the general technical data. Keep to the lower of the two values.
for ATEX		at U _i = 15 V , I _i = 25 mA , P _i = 34 mW , T6 : 55 °C (131 °F) T5 : 65 °C (149 °F) T4 : 95 °C (203 °F) T3 : 95 °C (203 °F) T2 : 95 °C (203 °F) T1 : 95 °C (203 °F) at U _i = 15 V , I _i = 25 mA , P _i = 64 mW , T6 : 50 °C (122 °F) T5 : 65 °C (149 °F) T4 : 90 °C (194 °F) T3 : 90 °C (194 °F) T2 : 90 °C (194 °F) T1 : 90 °C (194 °F) at U _i = 15 V , I _i = 52 mA , P _i = 169 mW , T6 : 45 °C (113 °F) T5 : 55 °C (131 °F) T4 : 75 °C (167 °F) T3 : 75 °C (167 °F) T2 : 75 °C (167 °F) T1 : 75 °C (167 °F)

Technical Data

for IECEx		at $U_i = 15\text{ V}$, $I_i = 25\text{ mA}$, $P_i = 34\text{ mW}$, T6 : 70 °C (158 °F) T5 : 85 °C (185 °F) T4 : 100 °C (212 °F) T3 : 100 °C (212 °F) T2 : 100 °C (212 °F) T1 : 100 °C (212 °F) at $U_i = 15\text{ V}$, $I_i = 25\text{ mA}$, $P_i = 64\text{ mW}$, T6 : 70 °C (158 °F) T5 : 85 °C (185 °F) T4 : 100 °C (212 °F) T3 : 100 °C (212 °F) T2 : 100 °C (212 °F) T1 : 100 °C (212 °F) at $U_i = 15\text{ V}$, $I_i = 52\text{ mA}$, $P_i = 169\text{ mW}$, T6 : 60 °C (140 °F) T5 : 75 °C (167 °F) T4 : 75 °C (167 °F) T3 : 75 °C (167 °F) T2 : 75 °C (167 °F) T1 : 75 °C (167 °F)
Maximum values of the valve circuit		The value applies to each valve circuit. A cable length of 10 m is considered.
Voltage	U_i	max. 32 V
Current	I_i	max. 240 mA
Internal capacitance	C_i	max. 10 nF
Internal inductance	L_i	max. 20 μH
Equipment protection level Gb		
Type of protection		intrinsic safety
CE marking		[*PD-Z02585A*]
Certificates		
Appropriate type		NCN3-F31K2...-N4...
ATEX certificate		TÜV 17 ATEX 8125 X
ATEX marking		Ⓔ II 1G Ex ia IIC T6...T1 Ga
Standards		EN 60079-0:2012+A11:2013 , EN 60079-11:2012
IECEx certificate		IECEx TUR 17.0055X
IECEx marking		Ex ia IIC T6...T1 Ga
Standards		IEC 60079-0:2011 , IEC 60079-11:2011
Effective internal capacitance	C_i	max. 100 nF The value is applicable for one sensor circuit. A cable length of 10 m is considered.
Effective internal inductance	L_i	max. 100 μH The value is applicable for one sensor circuit. A cable length of 10 m is considered.
Maximum permissible ambient temperature	T_{amb}	Also observe the maximum permissible ambient temperature stated in the general technical data. Keep to the lower of the two values. at $U_i = 15\text{ V}$, $I_i = 25\text{ mA}$, $P_i = 34\text{ mW}$, T6 : 70 °C (158 °F) T5 : 85 °C (185 °F) T4 : 100 °C (212 °F) T3 : 100 °C (212 °F) T2 : 100 °C (212 °F) T1 : 100 °C (212 °F) at $U_i = 15\text{ V}$, $I_i = 25\text{ mA}$, $P_i = 64\text{ mW}$, T6 : 70 °C (158 °F) T5 : 85 °C (185 °F) T4 : 100 °C (212 °F) T3 : 100 °C (212 °F) T2 : 100 °C (212 °F) T1 : 100 °C (212 °F) at $U_i = 15\text{ V}$, $I_i = 52\text{ mA}$, $P_i = 169\text{ mW}$, T6 : 60 °C (140 °F) T5 : 75 °C (167 °F) T4 : 75 °C (167 °F) T3 : 75 °C (167 °F) T2 : 75 °C (167 °F) T1 : 75 °C (167 °F)
Maximum values of the valve circuit		The value applies to each valve circuit. A cable length of 10 m is considered.
Voltage	U_i	max. 32 V
Current	I_i	max. 240 mA

Release date: 2020-03-25 Date of issue: 2020-03-30 Filename: 235078_eng.pdf

Technical Data

Internal capacitance	C_i	max. 10 nF
Internal inductance	L_i	max. 20 μ H
Equipment protection level Gc (ic)		
Type of protection		intrinsic safety
CE marking		[*PD-Z02586A*]
Certificates		
ATEX certificate		PF 13 CERT 2895 X
ATEX marking		Ⓔ II 3G Ex ic IIC T6...T1 Gc
Standards		EN 60079-0:2012+A11:2013 , EN 60079-11:2012
Effective internal capacitance	C_i	max. 100 nF The value is applicable for one sensor circuit. A cable length of 10 m is considered.
Effective internal inductance	L_i	max. 100 μ H The value is applicable for one sensor circuit. A cable length of 10 m is considered.
Maximum permissible ambient temperature	T_{amb}	Also observe the maximum permissible ambient temperature stated in the general technical data. Keep to the lower of the two values. at $U_i = 20$ V , $I_i = 25$ mA , $P_i = 34$ mW , T6 : 70 °C (158 °F) T5 : 85 °C (185 °F) T4 : 100 °C (212 °F) T3 : 100 °C (212 °F) T2 : 100 °C (212 °F) T1 : 100 °C (212 °F) at $U_i = 20$ V , $I_i = 25$ mA , $P_i = 64$ mW , T6 : 70 °C (158 °F) T5 : 85 °C (185 °F) T4 : 100 °C (212 °F) T3 : 100 °C (212 °F) T2 : 100 °C (212 °F) T1 : 100 °C (212 °F) at $U_i = 20$ V , $I_i = 52$ mA , $P_i = 169$ mW , T6 : 60 °C (140 °F) T5 : 75 °C (167 °F) T4 : 75 °C (167 °F) T3 : 75 °C (167 °F) T2 : 75 °C (167 °F) T1 : 75 °C (167 °F)
Maximum values of the valve circuit		The value applies to each valve circuit. A cable length of 10 m is considered.
Voltage	U_i	max. 32 V
Current	I_i	max. 240 mA
Internal capacitance	C_i	max. 10 nF
Internal inductance	L_i	max. 20 μ H
Equipment protection level Mb		
Type of protection		intrinsic safety
CE marking		[*PD-Z02585A*]
Certificates		
Appropriate type		NCN3-F31K2...-N4...
IECEX certificate		IECEX TUR 17.0055X
IECEX marking		Ex ia I Mb
Standards		IEC 60079-0:2011 , IEC 60079-11:2011
Effective internal capacitance	C_i	max. 100 nF The value is applicable for one sensor circuit. A cable length of 10 m is considered.
Effective internal inductance	L_i	max. 100 μ H The value is applicable for one sensor circuit. A cable length of 10 m is considered. negligibly small
Maximum permissible ambient temperature	T_{amb}	Also observe the maximum permissible ambient temperature stated in the general technical data. Keep to the lower of the two values. at $U_i = 15$ V , $I_i = 25$ mA , $P_i = 34$ mW : 100 °C (212 °F) at $U_i = 15$ V , $I_i = 25$ mA , $P_i = 64$ mW : 100 °C (212 °F) at $U_i = 15$ V , $I_i = 52$ mA , $P_i = 169$ mW : 75 °C (167 °F)
Maximum values of the valve circuit		The value applies to each valve circuit. A cable length of 10 m is considered.

Release date: 2020-03-25 Date of issue: 2020-03-30 Filename: 235078_eng.pdf

Technical Data

Voltage	U_i	max. 32 V
Current	I_i	max. 240 mA
Internal capacitance	C_i	max. 10 nF
Internal inductance	L_i	max. 20 μ H
General information		
Use in the hazardous area		see instruction manuals

Connection

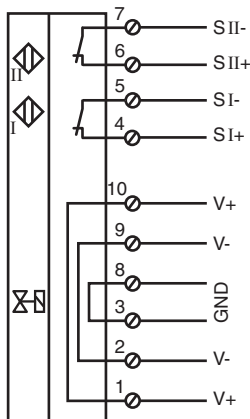

Additional Information

Interruption of LED:

In the case of a polarity reversal of the valve circuit connection/s, the valve status display does not function, i.e. such that low power valves can (also) be connected.

Matching system components



	BT115A	Activator for F31 series
	BT115X	Activator for F31 series

Accessories

	BT65-F31K2-RG-EN	Activator for F31K2 series
--	-------------------------	----------------------------

Release date: 2020-03-25 Date of issue: 2020-03-30 Filename: 235078_eng.pdf

Accessories

	<p>BT65A</p>	<p>Activator for F31 series</p>
	<p>BT65X</p>	<p>Activator for F31 series</p>

Release date: 2020-03-25 Date of issue: 2020-03-30 Filename: 235078_eng.pdf

Refer to "General Notes Relating to Pepperl+Fuchs Product Information".

Pepperl+Fuchs Group
www.pepperl-fuchs.com

USA: +1 330 486 0001
fa-info@us.pepperl-fuchs.com

Germany: +49 621 776 1111
fa-info@de.pepperl-fuchs.com

Singapore: +65 6779 9091
fa-info@sg.pepperl-fuchs.com