



Model number

PGV100-F200A-R4-V19

Read head for incident light positioning system

Features

- Mechanically rugged: no wearing parts, long operating life, maintenance-free
- RS-485 interface
- Noncontact lane tracking of a colored strip
- Noncontact positioning along the colored strip using Data Matrix codes
- Reading of Data Matrix control codes

Diagrams

Coordinates

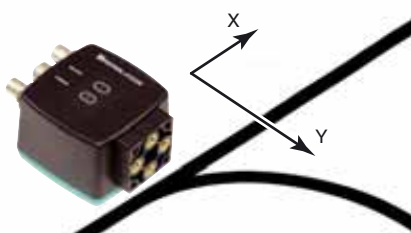

System components

PGV*-CA25-*

Data Matrix code tape

VAZ-V1S-B

Blind plug for M12 sockets

Technical data

General specifications

Passage speed v	≤ 8 m/s
Measuring range	max. 10000 m
Light type	Integrated LED lighting (white/blue)
Read distance	100 mm
Depth of focus	± 20 mm
Reading field	120 mm x 80 mm
Ambient light limit	100000 Lux
Resolution	± 0.2 mm

Nominal ratings

Camera	
Type	CMOS , Global shutter
Processor	
Clock pulse frequency	600 MHz
Speed of computation	4800 MIPS

Functional safety related parameters

MTTF _d	96 a
Mission Time (T _M)	20 a
Diagnostic Coverage (DC)	0 %

Indicators/operating means

LED indication	7 LEDs (communication, alignment aid, status information)
----------------	---

Electrical specifications

Operating voltage U_B	15 ... 30 V DC , PELV
No-load supply current I_0	max. 200 mA
Power consumption P_0	3 W

Interface

Interface type	RS 485 interface
Data output code	binary code
Transfer rate	38400 ... 230400 Bit/s
Termination	Switchable terminal resistor
Query cycle time	≥ 10 ms

Input

Input type	1 to 3 functional inputs , programmable
Input impedance	≥ 27 k Ω

Output

Output type	1 to 3 switch outputs , PNP , programmable , short-circuit protected
Switching voltage	Operating voltage
Switching current	150 mA each output

Standard conformity

Emitted interference	EN 61000-6-4:2007+A1:2011
Noise immunity	EN 61000-6-2:2005
Shock resistance	EN 60068-2-27:2009
Vibration resistance	EN 60068-2-6:2008

Ambient conditions

Operating temperature	0 ... 60 °C (32 ... 140 °F) , -20 ... 60 °C (-4 ... 140 °F) (noncondensing; prevent icing on the lens!)
Storage temperature	-20 ... 85 °C (-4 ... 185 °F)
Relative humidity	90 % , noncondensing

Mechanical specifications

Connection type	8-pin, M12 x 1 connector
Housing width	70 mm
Housing height	70 mm
Housing depth	50 mm
Degree of protection	IP67
Material	
Housing	PC/ABS
Mass	approx. 160 g

Approvals and certificates

UL approval	cULus Listed, General Purpose, Class 2 Power Source, Type 1 enclosure
CCC approval	CCC approval / marking not required for products rated ≤ 36 V

Dimensions

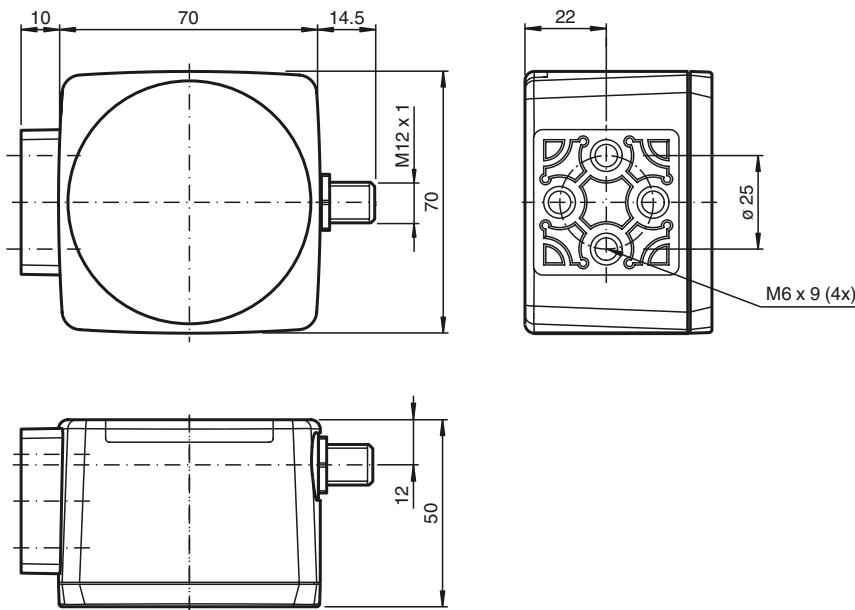

Electrical connection

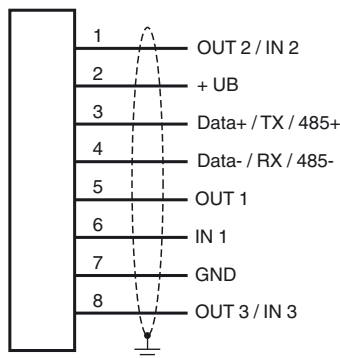

Pinout

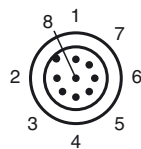

General

The PGV... reader forms part of the positioning system in the Pepperl+Fuchs incident light process. The reader's features include a camera module and an integrated illumination unit. The reader uses these features to detect a colored strip stuck to the floor to track the lane. The reader also detects control codes and position markers in the form of Data Matrix codes attached to a self-adhesive code tape. The code tape is usually mounted in a fixed position instead of the colored strip or parallel to the colored strip. The reader is located on the front of an automated guided vehicle and guides this vehicle along the colored strip.

System components

PGV*-CC25-*

Control code tape für PGV System

PGV25M-CD100-CLEAR

Protective laminate for PGV code tape

Additional information

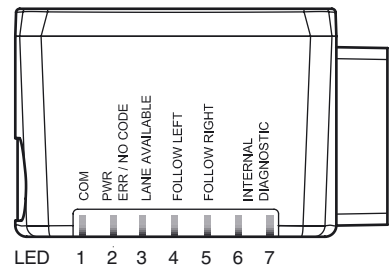
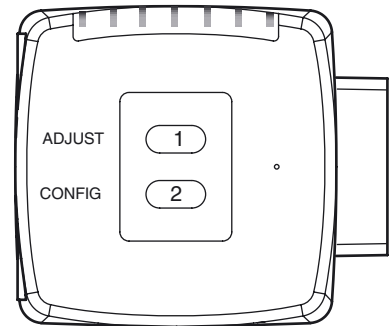

Accessories

PCV-USB-RS485-Converter Set

USB to RS 485 interface converter

PCV-KBL-V19-STR-RS485

Cable unit with power supply for USB / RS-485 interface converter

V19-G-ABG-PG9

Female connector, M12, 8-pin, shielded, field attachable

V19-G-ABG-PG9-FE

Female connector, M12, 8-pin, shielded, field attachable

PCV-SC12

Grounding clip for PCV system

PCV-AG100

Alignment guide for PCV100-* read head

PCV-LM25

Marker head for 25 mm code tape

PCV-MB1

Mounting bracket for PCV* read head

PGV33M-CB19-BU

PGV color-tape blue

PGV33M-CB19-GN

PGV color-tape green

PGV33M-CB19-RD

PGV color-tape red

Release date: 2019-04-01 16:52 Date of issue: 2019-04-01 261183_eng.xml

Accessories

PGV33M-CB19-YE

PGV color-tape yellow

Vision Configurator

Operating software for camera-based sensors

Mounting and Commissioning

Mount the reader such that the optical surface of the device captures the optimum reading distance to the colored strip (see "Technical Data"). The stability of the mounting and the manner in which the vehicle is guided ensure that the reader is not operated outside of its depth of focus range. The colored strip must not leave the maximum reading window for the reader during this process.

All readers can be adapted to optimally meet specific requirements by means of parameterization.

Indicators and Operating Controls

The PGV... reader is equipped with seven indicator LEDs for carrying out visual function checks and rapid diagnostics. The reader is equipped with two buttons at the back for activating the alignment aid and parameterization mode.

LEDs

LED	Color	Label	Meaning
1	Yellow	COM	Communication active
2	Green/red	PWR ERR/NO CODE	Code detected/not detected, error
3	Yellow	LANE AVAILABLE	Lane available
4	Yellow	FOLLOW LEFT	"Follow left-hand lane" activated
5	Yellow	FOLLOW RIGHT	"Follow right-hand lane" activated
6	Red/green/yel- low	INTERNAL	Internal diagnostics
7		DIAGNOSTIC	

External Parameterization

In order to parameterize the device externally, the parameterization code is required in the form of a Data Matrix containing the desired reader parameters. Data Matrix code cards detailing the step-by-step process for externally parameterizing the device are printed in the operating instructions for the reader.

The reader can be parameterized only within ten minutes of being switched on. If a key is pressed after ten minutes of the device being switched on, a visual signal is given by the LEDs (LED1, yellow/LED2, red/LED3, yellow/LED4, yellow/LED5, yellow, flashing for two seconds).

- The switchover from normal mode to parameterization mode is made by pressing button 2 on the back of the reader. To switch the device over, button 2 must be pressed and held for more than two seconds. LED3 then flashes.

Note: Parameterization mode is exited automatically if the device is inactive for one minute. In this case, the reader reverts to normal mode and operates without the settings having been changed.
- Place the parameterization code in the field of vision of the camera module. After the parameterization code is detected, the green LED2 lights up for one second. In the event of an invalid parameterization code, LED2 lights up red for two seconds.
- Briefly pressing button 2 will end parameterization mode.