



## Model Number

LVL-A7-BG1A-E5V1-CG-EMS

## Features

- Limit switch for liquids
- Process connection G1/2
- Suitable for process temperatures up to 150 °C (302 °F)
- Rugged stainless steel housing
- Onsite function check possible thanks to LED indication
- External function test with test magnet

## Description

The Vibracon LVL-A7 is a limit switch for liquids and is used in tanks, vessels and pipes. The device is used for overflow prevention or pump protection in cleaning and filter systems as well as in cooling and lubrication vessels, for instance.

The device is suitable for applications in which float switches or conductive, capacitance and optical sensors have been used up to now. The device also works in areas where these measuring principles are not suitable due to conductivity, buildup, turbulence, flow conditions or air bubbles.

The device can be used for process temperatures up to 150 °C (302 °F).

The device is not suitable for use in hazardous areas.

For hygienic areas we recommend the use of Vibracon LVL A7H.

## Technical Data

### General specifications

Measuring method	The tuning fork is brought to its resonance frequency by means of a piezoelectric drive. If the tuning fork is covered by liquid, this frequency changes. The electronics monitor the resonance frequency and indicate whether the tuning fork is freely vibrating or is covered by liquid.
Construction type	compact device
Operating mode	MAX = maximum safety: The device keeps the electronic switch closed as long as the liquid level is below the fork. example application: overflow protection MIN = minimum safety: The device keeps the electronic switch closed as long as the fork is immersed in liquid. example application: dry running protection of pumps The electronic switch opens if the limit is reached, if a fault occurs or in the event of a power fails (quiescent current principle)

### Supply

Connection	This device may be used with any sequential circuit, as long as the circuit can support the electrical circuit values of the switching elements.
Rated voltage	$U_r$ 10 ... 35 V DC
Fusing	external 500 mA slow
Current consumption	< 15 mA
Power consumption	975 mW
Residual ripple	5 V <sub>SS</sub> at 0 ... 400 Hz

### Input

Measured variable	density
Measurement range	min. 0.7 g/cm <sup>3</sup>

### Output

Output type	switch output
Switching current	max. 250 mA

### Directive conformity

Electromagnetic compatibility	EN 61326-1:2006 , EN 61326-2-3:2006
Directive 2014/30/EU	EN 61326-1:2006 , EN 61326-2-3:2006
Directive 2004/108/EC	EN 61326-1:2006 , EN 61326-2-3:2006

### Conformity

Electromagnetic compatibility	NE 21
Degree of protection	IEC 60529
Shock resistance	EN 60068-2-27
Vibration resistance	EN 60068-2-64
Climate class	DIN EN 60068-2-38/IEC 68-2-38

### Measurement accuracy

Reference operating conditions	- ambient temperature: 25 °C (+77 °F) - process pressure: 1 bar (14.5 psi) - fluid: water (density: approx. 1 g/cm <sup>3</sup> , viscosity: 1 mm <sup>2</sup> /s) - medium temperature: 25 °C (+77 °F) - density setting: > 0.7 g/cm <sup>3</sup> - switching time delay: standard (0,5 s, 1 s)
Measured value resolution	< 0.5 mm
Measuring frequency	approx. 1100 Hz in air
Switching point	13 mm ± 1 mm
Non-repeatability	± 1 mm acc. to DIN 61298-2
Hysteresis	max. 3 mm
Influence of ambient temperature	negligible
Influence of medium temperature	-25 µm/°C
Influence of medium pressure	-20 µm/bar
Switching time	- 0.5 s when tuning fork is covered - 1.0 s when tuning fork is uncovered max. 3 s
Switch-on delay	max. 3 s

### Operating conditions

Installation conditions	see technical information (TI)
Installation position	see technical information (TI)
Ambient conditions	
Ambient temperature	-40 ... 70 °C (-40 ... 158 °F)
Storage temperature	-40 ... 85 °C (-40 ... 185 °F)
Shock resistance	a = 300 m/s <sup>2</sup> = 30 g, 3 planes x 2 directions x 3 shocks x 18 ms, as per test Ea a(RMS) = 50 m/s <sup>2</sup> , ASD = 1.25 (m/s <sup>2</sup> ) <sup>2</sup> /Hz, f = 5 to 2000 Hz, t = 3 x 2 h
Vibration resistance	
Process conditions	
Medium temperature	-40 ... 150 °C (-40 ... 302 °F)
Process pressure (static pressure)	-1 ... +40 bar (-14.5 ... +580 psi)
State of aggregation	liquid
Density	min. 0.7 g/cm <sup>3</sup>
Viscosity	1 ... 10000 mPa/s, dynamic viscosity
Solid contents	< Ø5 mm

### Mechanical specifications

Degree of protection	IP65/IP67 , NEMA 4X
Connection	M12 connector, 4-pin
Material	process connection and short tube: stainless steel 316L (1.4401/1.4435) tuning fork: stainless steel 316L housing cover and connector: PPSU
Surface quality	R <sub>a</sub> < 3.2 µm
Mass	approx. 140 g
Process connection	thread G1/2 to ISO 228

### Indication and operation

Display elements	The LED display is on the connection side. - green LED: indication of ready to operate - red LED: fault indication - yellow LED: operating mode indication
Function test	function test with test magnet (optional accessory)

**Certificates and approvals**

CSA approval	cCSAus Listed, General Purpose
Overspill protection	see approval (ZE)

**General information**

Supplementary documentation	technical information (TI) manual (BA) approval (ZE)
Supplementary information	Statement of Conformity, Declaration of Conformity, Attestation of Conformity and instructions have to be observed where applicable. For information see <a href="http://www.pepperl-fuchs.com">www.pepperl-fuchs.com</a> .

**Accessories**

Designation	see technical information (TI)
-------------	--------------------------------

**Dimensions**

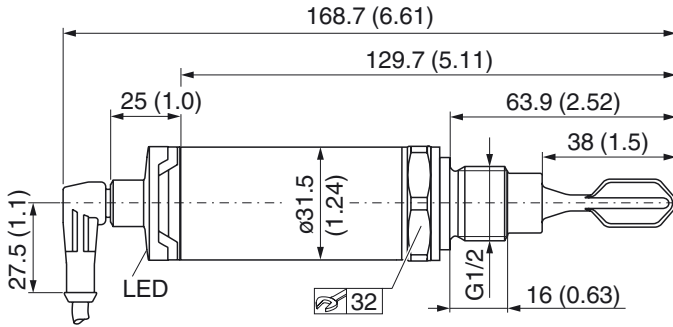

**Electrical Connection**

