



**Model Number**

**BT65-F31-RG-EN**

Activator for F31 and F31K series including protective housing

**Features**

- High-visibility valve position display
- Protection against contamination and damage
- Captive screws for easy mounting
- Two actuation targets in two levels with 5° setting grid
- Suitable for right and left rotating drives

**Technical Data**

**General specifications**

Ring diameter	≤ 65 mm
Spring ring height	≤ 6 mm

**Nominal ratings**

Valve status indicator	red = CLOSED green = OPEN
------------------------	------------------------------

**Ambient conditions**

Ambient temperature	-25 ... 70 °C (-13 ... 158 °F)
---------------------	--------------------------------

**Mechanical specifications**

Shaft diameter	≤ 49 mm
Shaft height	20 mm and 30 mm
Mounting hole pattern	30 x 80 mm
<b>Material</b>	
Housing	PC
Actuator	PA
Spacer disk	PA (1 unit, 10 mm strong)
Mounting screw	Stainless steel 1.4401 / AISI 316
Activation target	Stainless steel 1.4305 / AISI 303 (integrated)

**General information**

Scope of delivery	1 screw M6 x 30 1 screw M6 x 40 1 Activator for F31K2 series 1 Distance disc 1 Protective cover 2 captive Fixing screws M5 x 16
-------------------	--

**Compliance with standards and directives**

Standard conformity	
Standards	VDI / VDE 3845

**Dimensions**

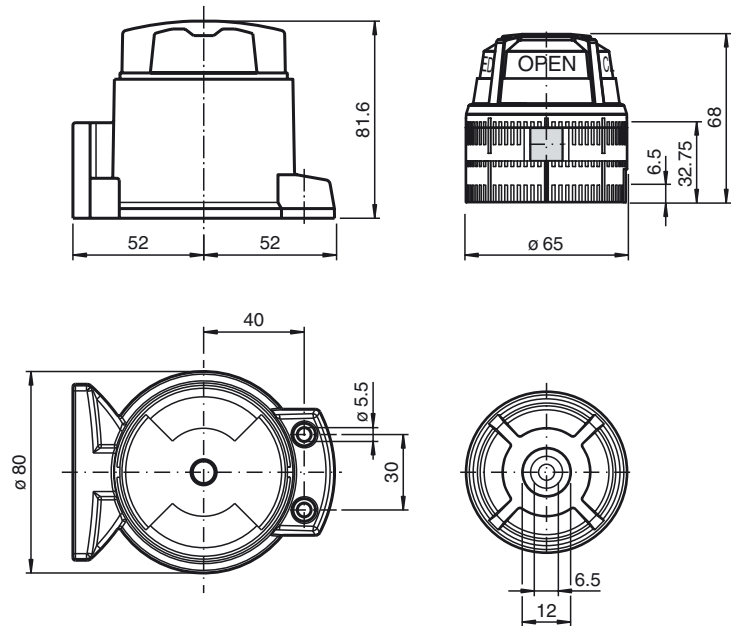

Release date: 2016-12-21 16:13 Date of issue: 2016-12-21 289310\_eng.xml