



Model number

PGV100A-F200-B28-V1D

Read head for incident light positioning system

Features

- SIL 3 (EN 61508)
- Category 4 PL e (EN ISO 13849)
- PROFINET interface
- PROFIsafe interface
- Safe, non-contact positioning on Data Matrix code tape
- Traverse distance up to 100 km
- Mechanically rugged: no wearing parts, long operating life, maintenance-free

Diagramms

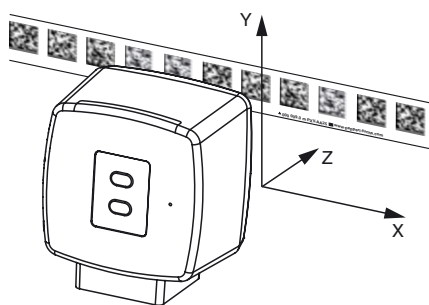

System components

PXV*-AA25*-*

Data Matrix code tape

Technical data

General specifications

Passage speed v	≤ 8 m/s
Measuring range	max. 100000 mm
Light type	Integrated LED lightning (red/blue)
Read distance	100 mm
Depth of focus	± 30 mm
Field of view	typ. 120 mm x 80 mm
Ambient light limit	30000 Lux
Accuracy	
Non safety-related X, Y	± 0.2 mm
Non safety-related angle α	± 0.5 °
Safety-related X	See the original instructions

Nominal ratings

Camera	
Type	CMOS , Global shutter
Processor	
Clock pulse frequency	600 MHz
Speed of computation	4800 MIPS

Functional safety related parameters

Safety Integrity Level (SIL)	SIL 3
Performance level (PL)	PL e
Category	Cat. 4
Reaction time	165 ms
MTTF	41.66 a
MTTF _d	104.74 a
Mission Time (T _M)	20 a
PFH	1.09 E-8 typ.

Indicators/operating means

LED indication	7 LEDs (communication, status messages)
----------------	---

Electrical specifications

Operating voltage U _B	20 ... 30 V DC , PELV
No-load supply current I ₀	max. 300 mA
Power consumption P ₀	6 W

Interface

Interface type	100 BASE-TX
Protocol	PROFINET IO Real-Time (RT) Conformance class B
Transfer rate	100 MBit/s

Conformity

Fieldbus standard	PROFIsafe in accordance with IEC 61784-3-3; profile 2.4
Functional safety	EN ISO 13849-1:2015 ; EN 61508:2010 part 1-7 ; EN 62061:2005 + AC:2010 + A1:2013 + A2:2015
Shock resistance	EN 60068-2-27:2009
Vibration resistance	EN 60068-2-6:2008
Emitted interference	EN 61000-6-4:2007+A1:2011
Noise immunity	EN 61000-6-7:2015
Photobiological safety	risk group 2 according IEC 62471

Ambient conditions

Operating temperature	0 ... 45 °C (32 ... 113 °F) , -20 ... 45 °C (-4 ... 113 °F) (noncondensing; prevent icing on the lens!)
Storage temperature	-40 ... 85 °C (-40 ... 185 °F)
Relative humidity	90 % , noncondensing
Altitude	≤ 2000 m above MSL

Mechanical specifications

Connection type	8-pin, M12x1 connector, standard 4-pin, M12x1 socket, D-coded (LAN) 4-pin, M12x1 socket, D-coded (LAN)
Housing width	70 mm
Housing height	70 mm
Housing depth	50 mm
Degree of protection	IP67
Material	
Housing	PC/ABS
Mass	approx. 200 g

Approvals and certificates

CE conformity	CE
CCC approval	CCC approval / marking not required for products rated ≤36 V
TÜV approval	TÜV Rheinland 01/205/5669.00/18

Dimensions

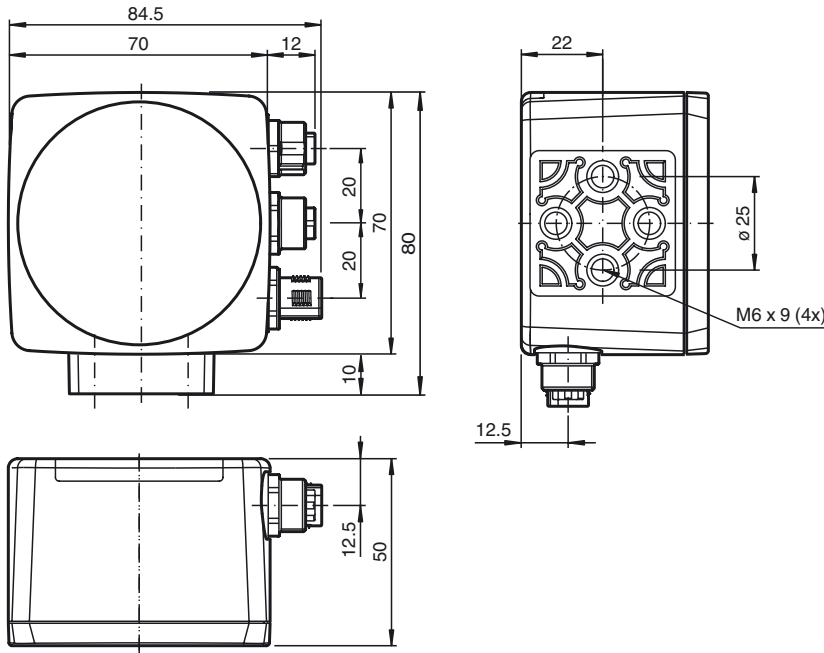

Additional information

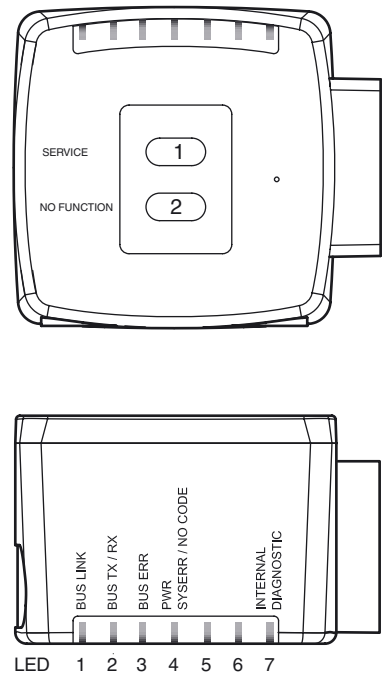

Electrical connection

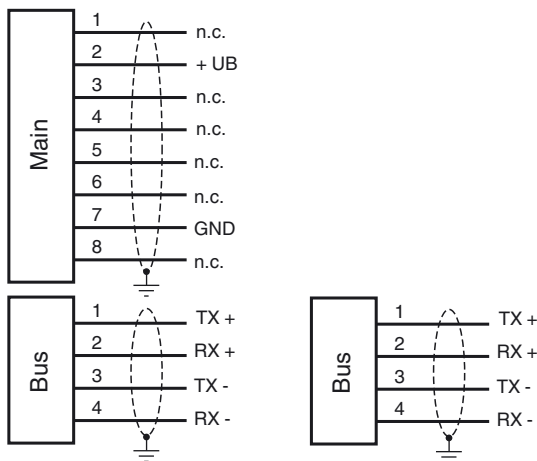

Pinout

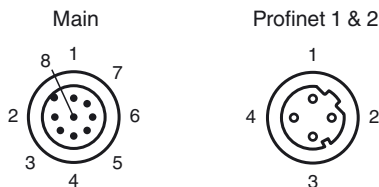

Accessories

- PGV25M-CD100-CLEAR**
Protective laminate for PGV code tape
- PCV-AG100**
Alignment guide for PCV100-* read head
- PCV-SC12**
Grounding clip for PCV system
- PCV-SC12A**
Grounding clip for PCV system
- PCV-LM25**
Marker head for 25 mm code tape
- PCV-MB1**
Mounting bracket for PCV* read head
- V1SD-G-2M-PUR-ABG-V1SD-G**
Ethernet bus cable, M12 to M12, PUR cable 4-pin, CAT5e
- V1SD-G-5M-PUR-ABG-V1SD-G**
Ethernet bus cable, M12 to M12, PUR cable 4-pin, CAT5e
- V1SD-G-10M-PUR-ABG-V1SD-G**
Ethernet bus cable, M12 to M12, PUR cable 4-pin, CAT5e
- V1SD-G-5M-PUR-ABG-V45-G**
Connection cable, M12 to RJ-45, PUR cable 4-pin, CAT5e
- V1SD-G-10M-PUR-ABG-V45-G**
Connection cable, M12 to RJ-45, PUR cable 4-pin, CAT5e
- V1SD-G-30M-PUR-ABG-V45-G**
Connection cable, M12 to RJ-45, PUR cable 4-pin, CAT5e
- V19-G-ABG-PG9**

Release date: 2019-02-26 16:35 Date of issue: 2019-02-26 303881_eng.xml

Accessories

Female connector, M12, 8-pin, shielded, field attachable

V19-G-ABG-PG9-FE

Female connector, M12, 8-pin, shielded, field attachable

V19-G-2M-PUR-ABG

Female cordset, M12, 8-pin, shielded, PUR cable

V19-G-5M-PUR-ABG

Female cordset, M12, 8-pin, shielded, PUR cable

V19-G-10M-PUR-ABG

Female cordset, M12, 8-pin, shielded, PUR cable

Additional Information

Function

The reader forms part of the positioning system in the Pepperl+Fuchs incident light process, working with stationary Data Matrix code tapes mounted on the ground. The device's features include a camera module with an internal illumination unit, which follows a stationary Data Matrix code tape affixed to the ground in parallel in order to reliably detect the position. The device can be used in all applications where automated guided vehicles (AGV) are to be positioned precisely at marked positions along a given spur.

The positioning system issues position values that achieve the reliability required by SIL 3 and PL e, provided that the device is properly integrated into the plant according to the specifications given in the original instructions.

Mounting and Commissioning

Mount the reader such that the optical surface of the device captures the optimal reading distance to the Data Matrix code tape (see "Technical Data"). The stability of the mounting and the manner in which the vehicle is guided ensure that the reader is not operated outside of its depth of focus range. The code tape must not leave the maximum reading window for the reader during this process.

Displays and Operating Elements

The reader is equipped with the following indicator LEDs for carrying out visual function checks and quick diagnostics:

LEDs

LED	Color	Label	Meaning
1	Green	BUS LINK	PROFINET connection activated
2	Yellow	BUS TX/RX	Data transfer
3	Red	BUS ERR	PROFINET communication error
4	Red/green	PWR SYSERR/NO CODE	Code detected/not detected, error
5	-	-	No function
6	-	-	No function
7	Red/green/ yellow	INTERNAL DIAGNOSTIC	Internal diagnostics

The SERVICE button on the back of the device is used for internal service purposes.