

# RFID Transponder

## IUC76-F157-T17-M-FR1



- Operating frequency 865 ... 868 MHz
- Complies with EPC Gen2 (ISO/IEC 18000-63)
- Sturdy housing, suitable for rough industrial use
- Optimized for mounting on metal
- For general purpose applications

Data carrier for standard applications



### Dimensions

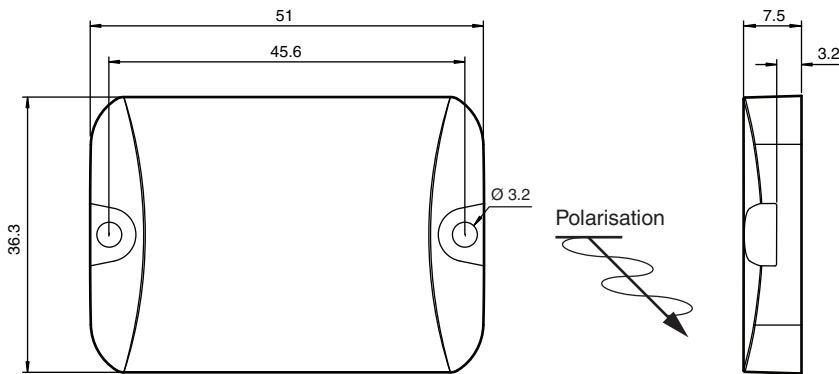

### Technical Data

General specifications	
Operating frequency	865 ... 868 MHz
Polarization	linear
Memory	
Chip Type	Higgs-3 (Alien)
Memory Bank 00 (Reserved)	64 Bit
Memory Bank 01 (EPC/UII)	96 ... 480 Bit
Memory Bank 10 (TID)	64 Bit
Memory Bank 11 (User memory)	512 Bit
Read cycles	unlimited
Write cycles	100000
Data retention period	50 years @ 77 °C (170.6 °F)
Directive conformity	
Radio equipment	
Directive 2014/53/EU	EN 302208
RoHS	

Release date: 2020-03-26 Date of issue: 2020-03-27 Filename: 309728\_eng.pdf

Refer to "General Notes Relating to Pepperl+Fuchs Product Information".

Pepperl+Fuchs Group  
www.pepperl-fuchs.com

USA: +1 330 486 0001  
fa-info@us.pepperl-fuchs.com

Germany: +49 621 776 1111  
fa-info@de.pepperl-fuchs.com

Singapore: +65 6779 9091  
fa-info@sg.pepperl-fuchs.com

## Technical Data

Directive 2011/65/EU (RoHS)	EN 50581
<b>Standard conformity</b>	
Degree of protection	EN 60529
RFID	ISO/IEC 18000-63
<b>Ambient conditions</b>	
Ambient temperature	-40 ... 85 °C (-40 ... 185 °F)
Storage temperature	-40 ... 150 °C (-40 ... 302 °F) 10 minutes at 250 °C (dry heat) for 250 test cycles, 1 hour cooling
Shock and impact resistance	3 ft (1m) to concrete up to 200 cycles
<b>Mechanical specifications</b>	
Degree of protection	IP68
Material	
Housing	PA 6
Installation	
On metal	yes
Mass	26 g
Construction type	Rectangular type

## Safety Information

High temperatures will cause the housing to expand.

If the housing is assembled under mechanical stress, the resulting pressure may damage the tag.

Install the tag loosely to allow for expansion due to high temperatures.

Release date: 2020-03-26 Date of issue: 2020-03-27 Filename: 309728\_eng.pdf

Refer to "General Notes Relating to Pepperl+Fuchs Product Information".

Pepperl+Fuchs Group  
www.pepperl-fuchs.com

USA: +1 330 486 0001  
fa-info@us.pepperl-fuchs.com

Germany: +49 621 776 1111  
fa-info@de.pepperl-fuchs.com

Singapore: +65 6779 9091  
fa-info@sg.pepperl-fuchs.com

 **PEPPERL+FUCHS**