

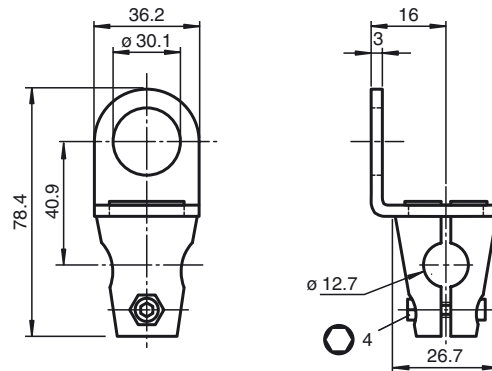

Dimensions



Model Number

MH 01-M30
Mounting brackets for sensors

Features

- Suitable for M30 sensors
- Simple and fast mounting

Technical data

General specifications

Inside diameter 30 mm

Mechanical specifications

Material Clamping cylinder: Diecast zinc
Support bracket: Steel

Note rod not included

Installation instructions

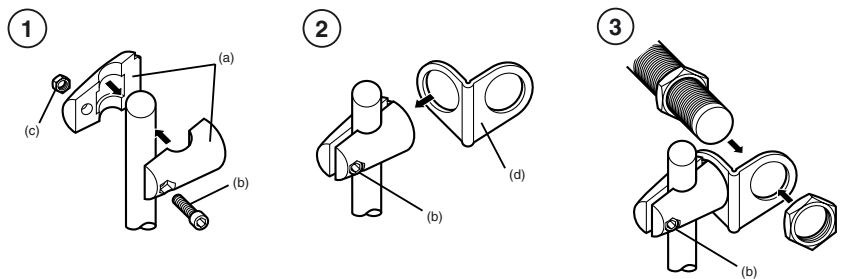

- ① Fasten the two parts of the mounting clamp (a) loosely by means of the screw (b) and the nut (c) supplied.
- ② Attach the mounting bracket (d) and then tighten the screw (b) in such a way that the bracket can still be turned.
- ③ Tighten the screw fully after the sensor has been mounted and aligned.

Release date: 2019-05-22 16:18 Date of issue: 2019-05-22 913299_eng.xml