

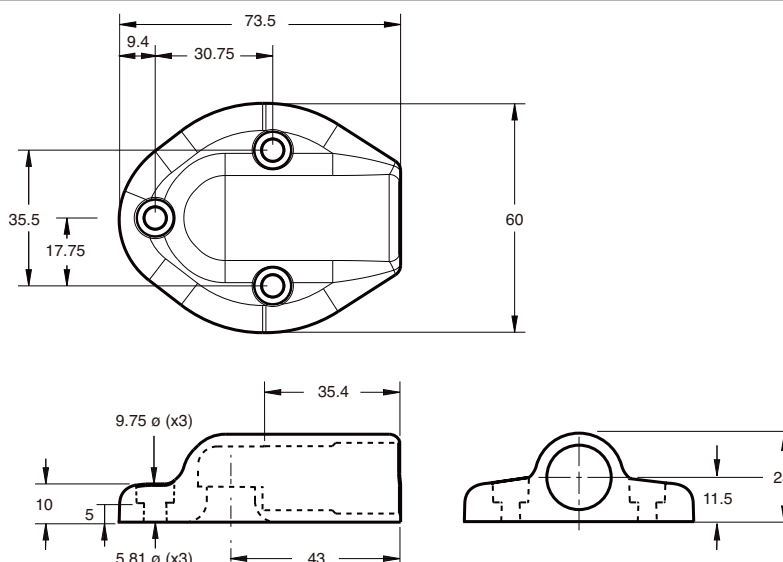

Dimensions



Model Number

MH-18GMA

Mounting flange for 18 mm diameter, right-angle ultrasonic sensors

Features

- Low profile
- Integral O-ring seal
- Press-fit sensor installation

Technical data

Mechanical specifications

Material	Sarlink® 5775B 75, fully cross-linked TPV, UV stabilized
Tightening torque	2 Nm
Mounting	Hardware includes 3 each of the following: M5 x 20 mm socket-cap stainless steel screws Stainless steel washers, Stainless steel nuts

General information

Supplementary information	For use with the following sensors: UBE1000-18GM40A-SE2-V1 UB300-18GM40A-E4-V1 UB300-18GM40A-E5-V1 UB300-18GM40A-U-V1 UB800-18GM40A-E4-V1 UB800-18GM40A-E5-V1 UB800-18GM40A-I-V1 UB800-18GM40A-U-V1
---------------------------	---

Product Description

The MH-18GMA flange accommodates all right angle-sensing, 18 mm diameter ultrasonic sensors.

Installation Instructions

- 1.) Install an M12 cordset onto the sensor's connector (Figure 1).



Figure 1

- 2.) Stabilize the MH-18GMA (i.e., within the palm of your hand—Figure 2).
- 3.) Hold the sensor at the connector with your other hand and press the transducer end of the sensor into the flange (Figure 2). Push the sensor into the flange until the white transducer is centered in the flange opening (Figure 3).

IMPORTANT: The compression fit is intentionally tight. A firm installation force is required.





Figure 2

Figure 3

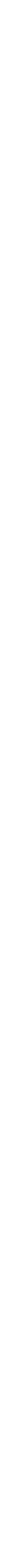

Release date: 2019-06-02 21:39 Date of issue: 2019-06-02 917015_eng.xml

Refer to "General Notes Relating to Pepperl+Fuchs Product Information".

Pepperl+Fuchs Group
www.pepperl-fuchs.com

USA: +1 330 486 0001
fa-info@us.pepperl-fuchs.com

Germany: +49 621 776 1111
fa-info@de.pepperl-fuchs.com

Singapore: +65 6779 9091
fa-info@sg.pepperl-fuchs.com