

Features

- Limit switch for liquids
- Large selection of process connections: universal use
- Wide variety of electronic modules (e. g., relay, thyristor signal output): the right connection for every process control system
- No calibration: quick and low-cost start up
- No mechanically moving parts: maintenance-free, no wear, long operating life
- Monitoring of the vibrating fork for damage: guaranteed function
- PROFIBUS PA protocol: commissioning and maintenance quick and easy
- Up to SIL 2 acc. to IEC 61508

Function

The device is a level limit switch for use in all liquids.

- for temperature from -50 °C to +150 °C
- for pressures up to 64 bar
- for viscosities up to 10000 mm²/s
- for densities up to 0.5 g/cm³ or 0.7 g/cm³ (other settings available on request)

The function is not affected by flow, turbulence, bubbles, foam, vibration, bulk solids content or build-up, the device is thus the ideal substitute for float switches.

The device is available with extension tube up to 3 m (up to 6 m on request).

High corrosion-resistant Alloy C4 (2.4610) is available for the vibration fork and process connection for applications in very aggressive liquids.

Devices with protection Ex ia and Ex d are available for use in explosion hazardous areas.

Assembly

Device with polyester housing P* and process connection G**

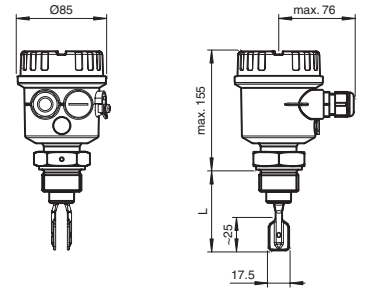

Device with aluminium housing A* and process connection with flange

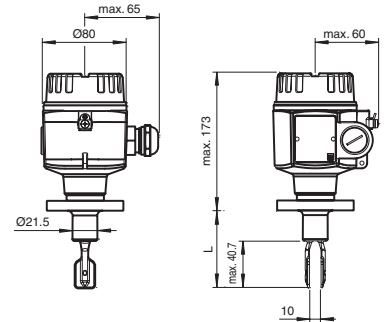

Additional dimensions see section dimensions. Length L see process connection.

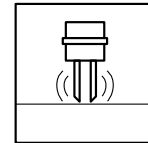

SIL 2



Connection

Connection FEL 52 (E5) 3-wire DC connection (example)

- preferably for use with memory programmable controls (PLC)
- positive signal at the switch output of the electronics (PNP)
- Output blocked on reaching limit level.
- also in compact housing with plug connection available

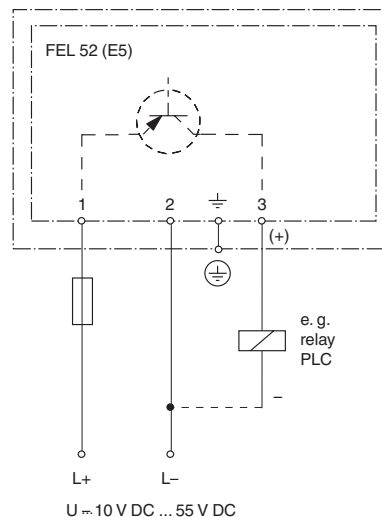

Other connection types see section electrical connection.

Release date 2019-05-17 11:18 Date of issue 2019-05-17 270755_eng.xml

Refer to "General Notes Relating to Pepperl+Fuchs Product Information".

General specifications	
Function principle	limit detection Maximum or minimum detection in tanks or pipelines containing all types of liquids including use in explosion hazardous areas. Particularly suited to very aggressive liquids thanks to high degree of corrosion protection.
Measuring method	The forks of the sensors vibrate at their intrinsic frequency. This frequency is reduced when covered with liquid. The change in frequency then activates the limit switch.
Construction type	compact device
Supply	
Rated voltage U_r	electronic insert FEL50A (PA): 9 ... 32 V DC electronic insert FEL51 (AC): 253 V AC, 50/60 Hz electronic insert FEL52 (E5): 10 ... 55 V DC electronic insert FEL54 (WA): 19 ... 253 V AC, 50/60 Hz or 19 ... 55 V DC electronic insert FEL55 (SI): 11 ... 36 V DC, PLC electronic insert FEL56 (N1), FEL58 (N2): isolating amplifier acc. to EN 60947-5-6 (NAMUR)
Current consumption	electronic insert FEL52 (E5): max. 15 mA
Power consumption	electronic insert FEL52 (E5): max. 0.83 W electronic insert FEL54 (WA): max. 1.3 W
Electrical specifications	
Surge protection	electronic insert FEL51 (AC), electronic insert FEL52 (E5), electronic insert FEL54 (WA), electronic insert FEL55 (SI): overvoltage category III
Input	
Switching point	see section switch point
Measured variable	limit level (limit value)
Measurement range	depends on mounting point
Output	
Switching delay	when fork is covered: approx. 0.5 s, when fork is exposed: approx. 1.0 s (other switching times on request) additionally configurable for PROFIBUS PA (electronic insert FEL50A (PA)): 0.5 ... 60 s
Switch behaviour	switch-over for minimum/maximum residual current safety on electronic insert MAX = maximum safety: The output switches to the power fail response when the fork is covered. for use with overspill protection for example MIN = minimum safety: The output switches to the power fail response when the fork is exposed. for use with dry running protection for example When switching on the power supply the output assumes the alarm signal. After max. 2 s it assumes the correct switching mode.
Directive conformity	
Electromagnetic compatibility	
Directive 89/336/EEC	EN 61326 If the fork tines are joined together on account of build-up, the useful signal is attenuated to such an extent that the original EMC values can no longer be completely observed (EN 61000-4-3 electromagnetic fields, EN 61000-4-6 HF coupling).
Low voltage	
Directive 73/23/EEC	EN 61010-1
Conformity	
Electromagnetic compatibility	NE 21
Degree of protection	IEC 60529
Vibration resistance	EN 60068-2-6
Climate class	DIN EN 60068-2-38/IEC 68-2-38
Input characteristics	
Medium density	adjustment on the electronic insert > 0,5 g/cm ³ or > 0,7 g/cm ³ (other on request)
Measurement accuracy	
Reference operating conditions	ambient temperature: 23 °C (73.4 °F), medium temperature: 23 °C (73.4 °F), product density: 1 g/cm ³ (water), viscosity: 1 mm ² /s, medium pressure p_e : 0 bar, sensor mounting: vertical from above, density switch: to > 0.7 g/cm ³
Maximum measured error	max. ± 1 mm, specified by mounting position
Non-repeatability	0.1 mm
Hysteresis	approx. 2 mm
Influence of medium density	max. +4.8 ... -3.5 mm (0.5 ... 1.5 g/cm ³)
Influence of medium temperature	max. +1.4 ... -2.8 mm (-40 ... 150 °C (-40 ... 302 °F))
Influence of medium pressure	max. 0 ... -2.5 mm (-1 ... 64 bar)
Operating conditions	
Installation conditions	
Installation position	with short pipe (up to 500 mm (19.7 inch)) any position, with long pipe vertical
Process conditions	
Medium temperature	-50 ... 150 °C (-58 ... 302 °F), exceptions see process connections
Medium pressure	$p_e = -1 ... 64$ bar (-14.5 ... 928.3 psi) over the entire temperature range, exceptions see process connections

Release date 2019-05-17 11:18 Date of issue 2019-05-17 270755_eng.xml

Refer to "General Notes Relating to Pepperl+Fuchs Product Information".

Test pressure	max. 100 bar (1.5 times the medium pressure p_e), no function during test pressure, burst pressure of diaphragm 200 bar
Thermal shock resistance	max. 120 °C/s (max. 120 K/s)
State of aggregation	liquid
Density	min. 0.5 g/cm ³ (compact housing 0.7 g/cm ³), other density settings on request
Viscosity	max. 10000 mm ² /s (max. 10000 cSt)
Solid contents	< Ø5 mm
Ambient conditions	
Ambient temperature	-50 ... 70 °C (-58 ... 158 °F) , function with reduced data values see section ambient temperature
Storage temperature	-50 ... 80 °C (-58 ... 176 °F)
Vibration resistance	10 ... 50 Hz, 0.15 mm, 100 cycles
Mechanical specifications	
Degree of protection	polyester, steel, and aluminum housing: IP66/IP67 compact housing: - IP65 with valve connector PG11 or 1/2NPT - IP66/IP68 with M12 x 1 connector without LEDs (1.4435/316L) - IP69K with M12 x 1 connector with LEDs (1.4435/316L)
Connection	electronic inserts: cross section max. 2.5 mm ² , lace in end splice in acc. with DIN 46228 ground lead in housing: cross section max. 2.5 mm ² external equipotential bonding: cross section 4 mm ²
Material	wetted parts: - process connection and extension tube: 1.4435/316L or 2.4610/Alloy C4 - vibration fork: 1.4435/316L or 2.4610/Alloy C4 - flat seal for process connection G2* or G3*: elastomer fibre, asbestos-free housings: - polyester housing: PBT-FR with PBT-FR cover or with PA12 cover with sight glass, cover seal: EPDM - stainless steel housing: 1.4435/316L, cover seal: silicone - aluminum housing: EN-AC-AISi10Mg, plastic-coated, cover seal: EPDM - compact housing with valve connector or M12 connector: 1.4435/316L cable gland: polyamide or brass, nickel-plated temperature spacer: 1.4435/316L flameproof bushing: 1.4435/316L
Surface quality	R _a < 3.2 µm/80 grit: length, spacer, bushings *A, *B, *E
Mass	600 g , basic weight: compact sensor, electronic insert, stainless steel housing, process connection G2* , additional weight is dependent on housing and process connection process connections: - A31 1000 g, A4* 1200 g, A5* 1500 g, A6* 2400 g, A72 4800 g, A81 4900 g, A82 6800 g, A91 7000 g, A92 11,5 kg, A93 17,3 kg - - C45 1400 g, C51 1200 g, C71 1600 g, C75 3200 g, C95 5900 g, CA3 5600 g - D45 1400 g, D51 1200 g, D71 1600 g, D75 3200 g, D95 5900 g, DA3 5600 g - F45 1400 g, F51 1200 g, F55 2000 g, F61 1400 g, F65 2400 g, F71 1600 g, F75 3200 g, F7F 2600 g, F81 2400 g, F85 4300 g, F93 4800 g, F95 5900 g, FA3 5600 g, FA5 7500 g - G3* 200 g - J13 no information, J16 no information, J17 1700 g, J19 no information, J1A no information, J1C 1700 g - N3* 200 g, N75 2900 g - R3* 200 g - T51 no information, T61 100 g extension tube, tempeprature spacers, flameproof bushings: - B* 900 g/m, C* 2300 g/100 inch - D* 100 g - J* 900 g/m and 600 g, K* 2300 g/100 inch and 600 g - L* 700 g - R* 900 g/m and 700 g, S* 2300 g/100 inch and 700 g - T* 800 g
Dimensions	housing: diameter max. 85 mm, height max. 173 mm temperature separator, flameproof bushing: additional length L 140 mm process connection: length L 66.5 ... 80 mm extension: length type II, for vertical installation from above same switching point as Vibracon LVL1, LVL2 vibration fork: width 17.5 mm, fork width 10 mm, length 25 mm
Process connection	- cylindrical thread G3/4A, G1A to DIN ISO 228/1 with flat seal to DIN 7603 - conical thread R3/4, R1 to DIN 2999, part 1 - conical thread 3/4NPT, 1NPT to ANSI B 1.20.1 - flush-mounted with welding sleeve to factory standard (G3/4A, G1A) - Triclamp 1-1/2 inch, 2 inch to ISO 2852 - flanges to EN 1092-1 from DN25, to ANSI B 16.5 from 1 inch, to JIS B 2238 (RF) from DN25 For further information see type code.
Data for application in connection with hazardous areas	
EU-Type Examination Certificate	see instruction manuals (SI)
International approvals	
FM approval	see control drawings (ZD)

Release date 2019-05-17 11:18 Date of issue 2019-05-17 270755_eng.xml

Refer to "General Notes Relating to Pepperl+Fuchs Product Information".

CSA approval	see control drawings (ZD)
IECEX approval	see instruction manuals (SI)
Indication and operation	
Display elements	<p>electronic inserts:</p> <ul style="list-style-type: none"> - electronic inserts FEL50 A (PA), FEL58 (N2): green LED, yellow LED - electronic inserts FEL51 (AC), FEL52 (E5), FEL54 (WA), FEL55 (SI), FEL56 (N1): green LED, red LED <p>compact housings:</p> <p>compact housing with valve connector</p> <ul style="list-style-type: none"> - electronic version FEL51 (AC), FEL52 (E5): green LED, red LED - electronic version FEL58 (N2): green LED, yellow LED <p>compact housing with M12 x 1 round connector without LEDs</p> <ul style="list-style-type: none"> - electronic version FEL52 (E5): green LED, yellow LED, red LED - electronic version FEL58 (N2): green LED, yellow LED <p>compact housing with M12 x 1 round connector with LEDs</p> <ul style="list-style-type: none"> - electronic version FEL52 (E5): green LED, two yellow LEDs
Control elements	<p>electronic insert FEL50A (PA): 8 switches for device address setting</p> <p>electronic inserts FEL51 (AC), FEL52 (E5), FEL54 (WA), FEL55 (SI), FEL56 (N1): two switches for fail-safe mode and density change</p> <p>electronic insert FEL58 (N2): two switches for fail-safe mode and density change and one test button interrupts lead</p>
Function test	<p>compact housing: function test with test magnet</p> <p>electronic versions FEL51 (AC), FEL52 (E5) and FEL58 (N2): During the test, the current state of the electronic switch is reversed.</p>
Certificates and approvals	
SIL classification	up to SIL2 acc. to IEC 61508
Overspill protection	see approval (ZE)
General information	
Supplementary documentation	<p>technical information (TI)</p> <p>manuals, brief instructions (BA, KA)</p> <p>instruction manuals (SI)</p> <p>control drawings (ZD)</p>
Supplementary information	EC-Type Examination Certificate, Statement of Conformity, Declaration of Conformity, Attestation of Conformity and instructions have to be observed where applicable. For information see www.pepperl-fuchs.com .
Accessories	
Designation	see technical information (TI)

Release date 2019-05-17 11:18 Date of issue 2019-05-17 270755_eng.xml

Ambient temperature

Permissible ambient temperature T_1 at the housing depends on the product temperature T_2 in the vessel:

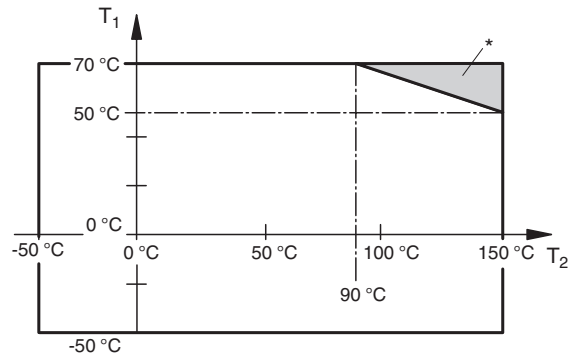
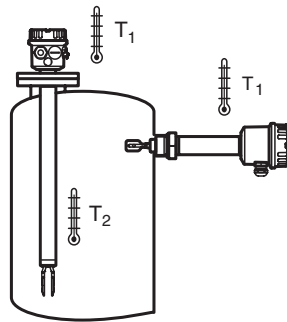

* additional temperature range for sensors with a temperature separator or pressure-tight bushing

Switch point

Switch point ► on the sensor depend on the mounting position, with reference to water, density 1 g/cm³, 23 °C, p_e 0 bar.

Note:

The switch points of the Vibracon LVL-M2C are at other positions to those of the previous versions LVL1, LVL2.

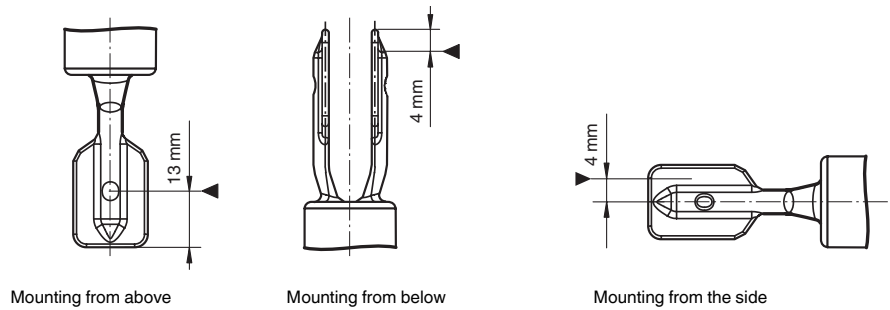

Electrical connection

Electronic insert FEL50A (PA)

2-wire connection for power supply and data transfer for connecting to PROFIBUS PA

Additional functions:

- Digital communication enables the representation, reading and editing of the following parameters: fork frequency, switch-on frequency, switch-off frequency, switch-on time and switch-off time, status, measured value, density switch.
- Matrix locking possible.
- Switch to WHG mode possible (WHG approval).
- You can also visit www.profibus.com for more information.

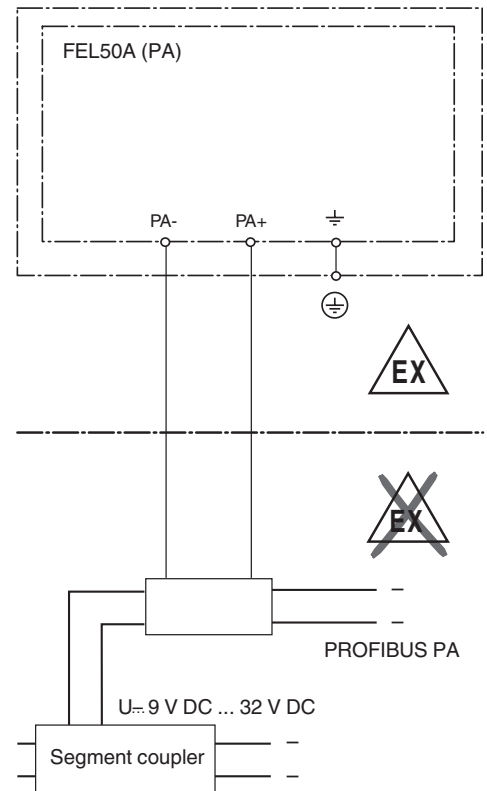

Electronic insert FEL51 (AC)

2-wire AC connection

Always connect in series with a load!

Check the following:

- the residual current in blocked state (up to 3.8 mA)
- that for low voltage
 - The voltage drop across the load is such that the minimum terminal voltage at the electronic insert (19 V) when blocked is not undershot.
 - The voltage drop across the electronics when switched through is observed (up to 12 V).
- that a relay cannot de-energise with holding power below 3.8 mA
If this is the case, a resistor should be connected parallel to the relay (RC module available on request).
- When selecting the relay, pay attention to the holding power/rated power (see connectable load).

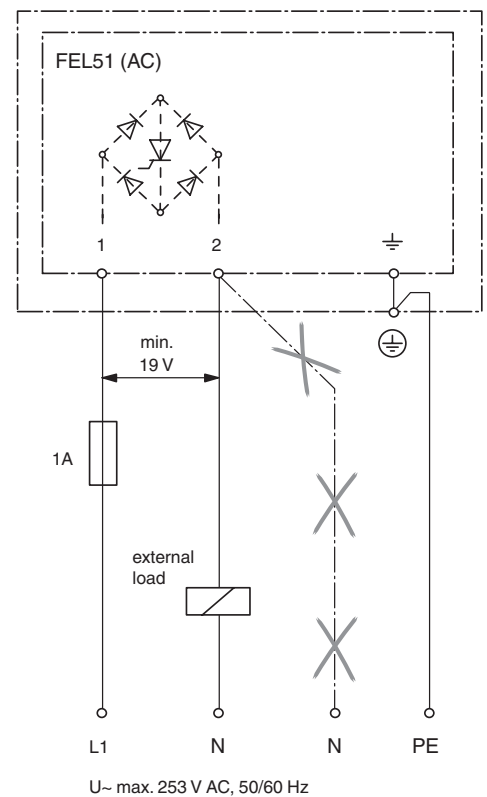

Release date 2019-05-17 11:18 Date of issue 2019-05-17 270755_eng.xml

Electrical connection

Electronic FEL51 (AC) in compact housing

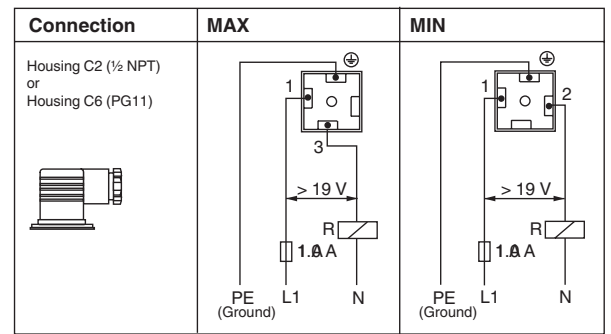

Electronic insert FEL52 (E5)

3-wire DC connection

- preferably used with programmable logic controllers (PLC), DI module as per EN 61131-2.
- positive signal at switching output of the electronics (PNP)
- Output blocked on reaching limit.

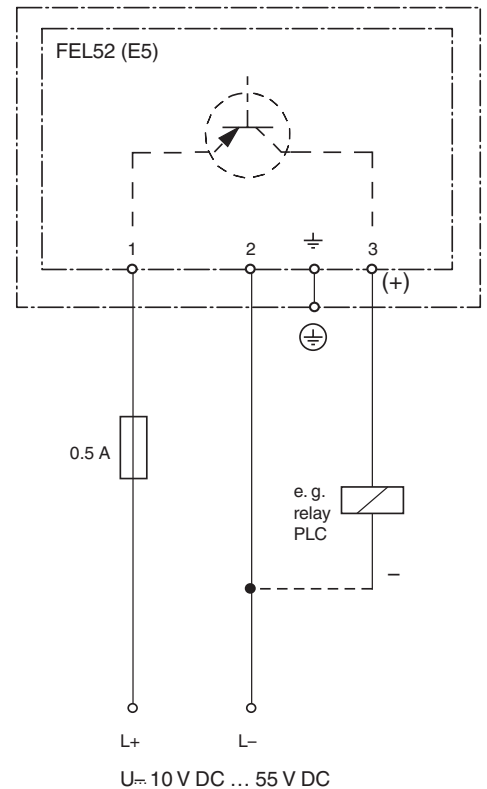

Electronic FEL52 (E5) in compact housing

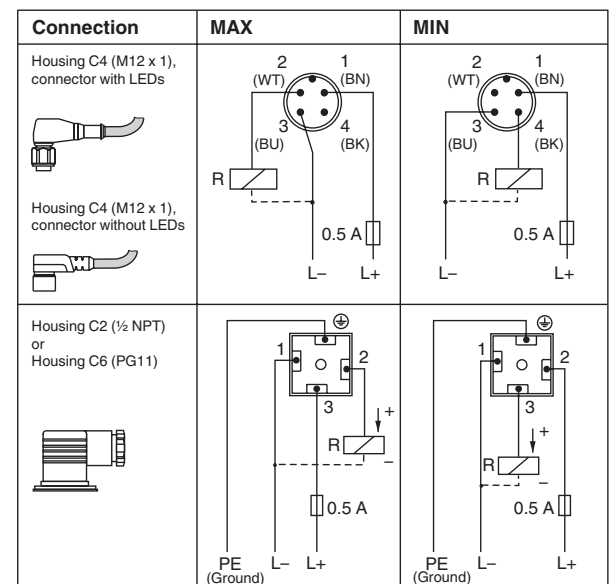

Release date 2019-05-17 11:18 Date of issue 2019-05-17 270755_eng.xml

Refer to "General Notes Relating to Pepperl+Fuchs Product Information".

Electrical connection

Electronic insert FEL54 (WA)

Universal current connection with relay output

- Power supply:
Please note the different voltage ranges for AC and DC.
- Output:
When connecting an instrument with high inductance, provide a spark arrester to protect the relay contact.
A fine-wire fuse (depending on the load connected) protects the relay contact on short-circuiting.
Both relay contacts switch simultaneously.

* When jumpered, the relay output works with NPN logic.

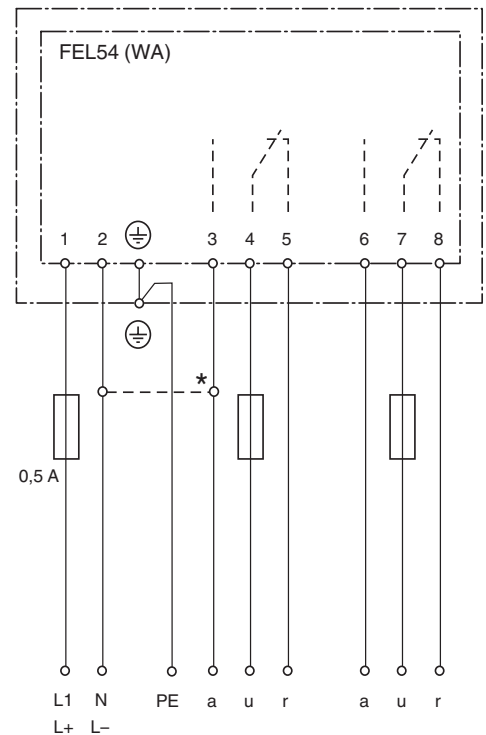

U~ 19 V AC ... 253 V AC, 50/60 Hz
U- 19 V DC ... 55 V DC

Electronic insert FEL55 (SI)

2-wire connection for separate switching unit

- for connecting to programmable logic controllers (PLC) for example, AI module 4 mA ... 20 mA to EN 61131-2
- Output signal jump from high to low current on limit (**H-L edge**)

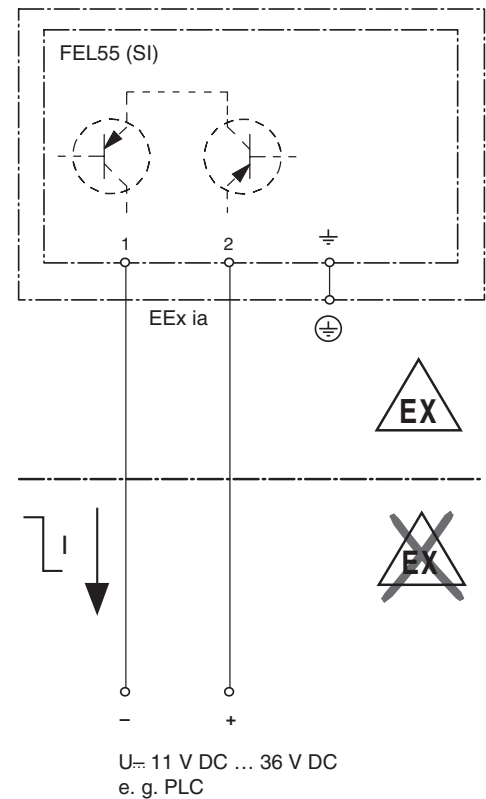

U= 11 V DC ... 36 V DC
e. g. PLC

Release date 2019-05-17 11:18 Date of issue 2019-05-17 270755_eng.xml

Electrical connection

Electronic insert FEL56 (N1)

2-wire connection for separate switching unit

- for connecting to switch amplifiers acc. to NAMUR (IEC 60947-5-6), e. g. switch amplifiers from Pepperl+Fuchs
- Output signal jump from low to high current on limit (**L-H edge**)

Connecting to multiplexer: set clock time to min. 2 s.

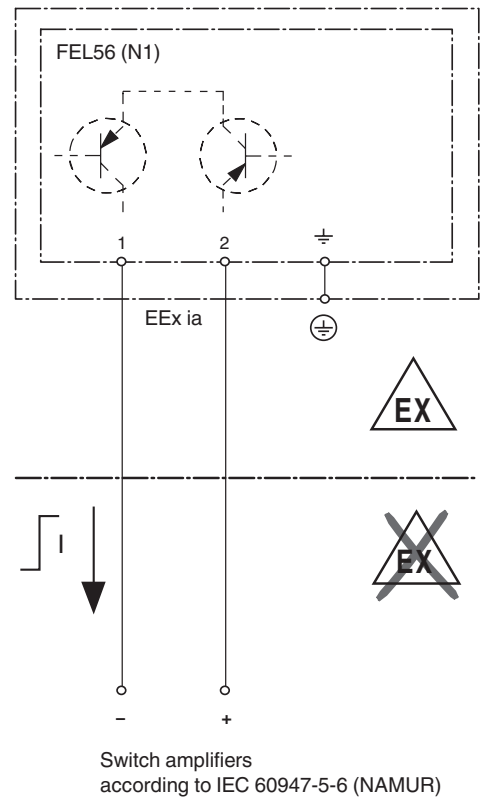

Electronic insert FEL58 (N2)

2-wire connection for separate switching unit

- for connecting to switch amplifiers acc. to NAMUR (IEC 60947-5-6), e. g. switch amplifiers from Pepperl+Fuchs
- Output signal jump from high to low current on limit (**H-L edge**)

Additional function:

Test key on the electronic insert. Pressing the key breaks the connection to the switch amplifier.

Connecting to multiplexer: set clock time to min. 2 s.

Note

For Ex-d applications, the additional function can only be used if the housing is not exposed to an explosive atmosphere.

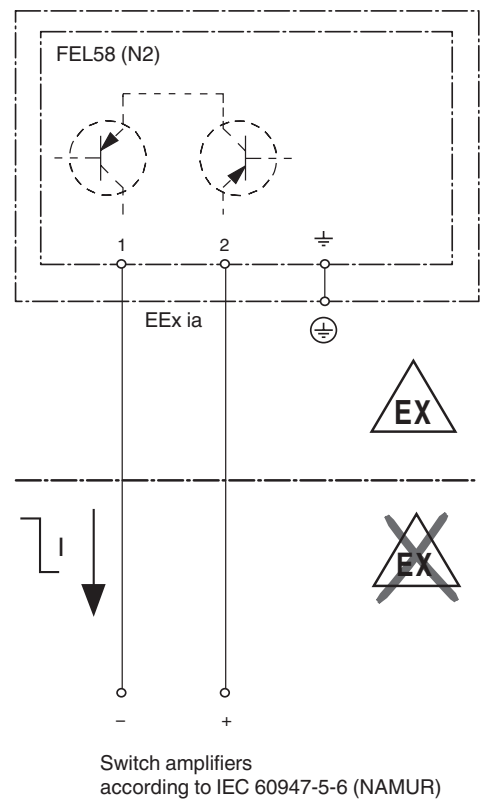

Release date 2019-05-17 11:18 Date of issue 2019-05-17 270755_eng.xml

Electrical connection

Electronic FEL58 (N2) in compact housing

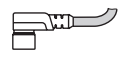
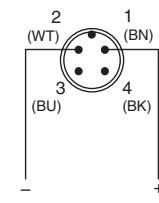
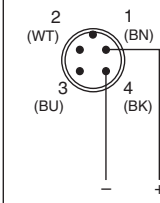
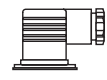
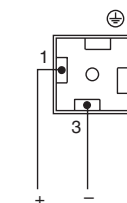
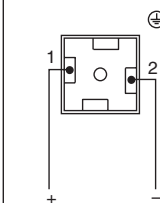
Connection	MAX	MIN
Housing C4 (M12 x 1), connector with LEDs  Housing C4 (M12 x 1), connector without LEDs 		
Housing C2 (½ NPT) or Housing C4 (PG11) 		

Dimensions

Compact housing C*

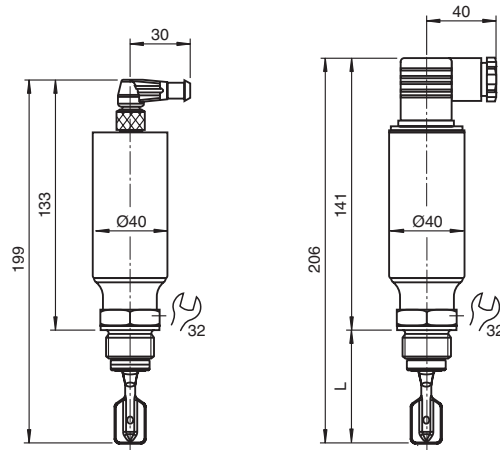

Stainless steel housing E*

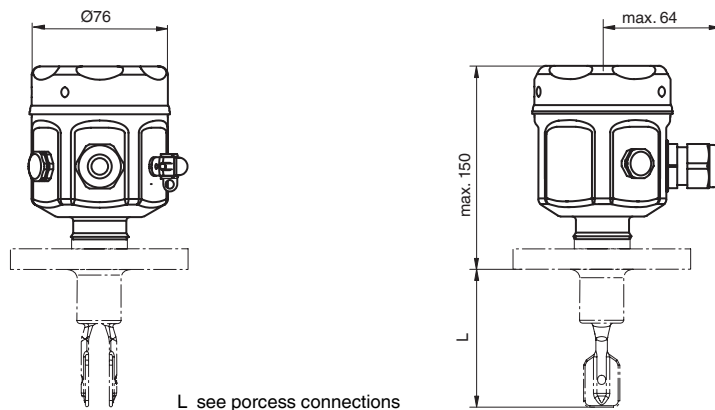

Process connections

A**, C**, D**, F**, J**, N75

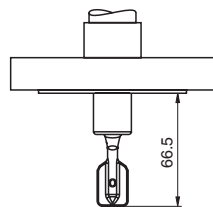

G2*

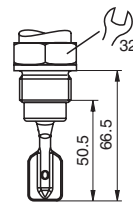

G3*

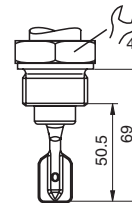

G3E

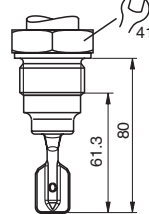

N2*

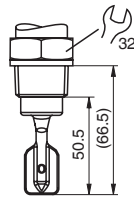

N3*

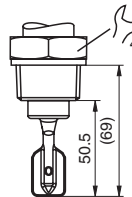

R2*

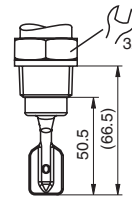

R3*

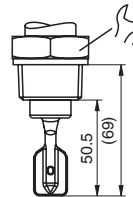

T**

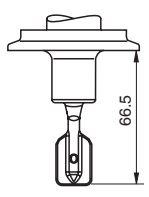

Release date 2019-05-17 11:18 Date of issue 2019-05-17 270755_eng.xml

Refer to "General Notes Relating to Pepperl+Fuchs Product Information".

Pepperl+Fuchs Group
www.pepperl-fuchs.com

USA: +1 330 486 0002
pa-info@us.pepperl-fuchs.com

Germany: +49 621 776 2222
pa-info@de.pepperl-fuchs.com

Singapore: +65 6779 9091
pa-info@sg.pepperl-fuchs.com

Dimensions

Extension tube

Thread: G3/4A
G1A

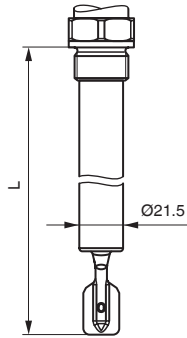

from seal surface of
thread adapter

Thread: 3/4NPT
1NPT
R3/4
R1

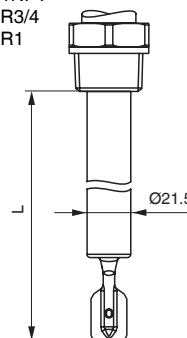

from lower edge
of thread

Flanges and flange-like
process connections

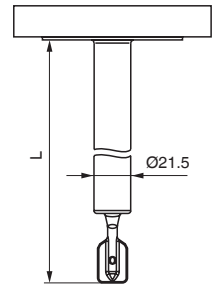

L = 148 mm ... 3000 mm
up to 6000 mm on request

Vibration fork

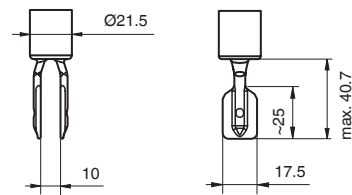

Accessories

Welding sleeves

- LVL-Z100, welding sleeve G3/4 for flush mounting for process connection G21
- LVL-Z101, welding sleeve G1 for flush mounting for process connection G3E
- LVL-Z102, welding sleeve G1 for flush mounting for process connection G3E

Flanges

- LVL-Z105, lap joint round flange DN50 PN40 form A with G1 thread for process connection G31
- LVL-Z106, lap joint round flange ANSI 2 inch with G1 thread for process connection G31
- LVL-Z107, lap joint square flange with G1 thread for process connection G31

Sliding sleeves

- LVL-Z120, sliding sleeve for unpressurised operation G1A
- LVL-Z121, sliding sleeve for unpressurised operation G1-1/2A
- LVL-Z122, sliding sleeve for unpressurised operation 1 NPT
- LVL-Z123, sliding sleeve for unpressurised operation 1-1/2 NPT
- LVL-Z124, high pressure sliding sleeve G1A
- LVL-Z125, high pressure sliding sleeve G1A, Alloy C4/2.4610
- LVL-Z126, high pressure sliding sleeve G1-1/2A
- LVL-Z127, high pressure sliding sleeve G1-1/2A, Alloy C4/2.4610
- LVL-Z128, high pressure sliding sleeve 1 NPT
- LVL-Z129, high pressure sliding sleeve 1 NPT, Alloy C4/2.4610
- LVL-Z130, high pressure sliding sleeve 1-1/2 NPT
- LVL-Z131, high pressure sliding sleeve 1-1/2 NPT, Alloy C4/2.4610

Further accessories

- LVL-Z108, cover with glass sight glass for stainless steel housing E*
- LVL-Z109, cover with PC sight glass for stainless steel housing E*
- LVL-Z110, transparent cover for polyester housing P*
- V1-G, mating connector, straight
- V1-W, mating connector, 90° angled

Type Code



*This overview does not mark options which are mutually exclusive.
Option with * = on request/in preparation.*

Device	
LVL-M2	Limit switch for liquids, device with extension tube
Process connection	
A31	Flange 1 inch, ANSI B 16.5, 150 lbs RF, 1.4435/316L
A41	Flange 1-1/4 inch, ANSI B 16.5, 150 lbs RF, 1.4435/316L
A42	Flange 1-1/4 inch, ANSI B 16.5, 300 lbs RF, 1.4435/316L
A51	Flange 1-1/2 inch, ANSI B 16.5, 150 lbs RF, 1.4435/316L
A52	Flange 1-1/2 inch, ANSI B 16.5, 350 lbs RF, 1.4435/316L
A61	Flange 2 inch, ANSI B 16.5, 150 lbs RF, 1.4435/316L
A6C	Flange 2 inch, ANSI B 16.5, 150 lbs RF, 2.4610/Alloy C4, platinized
A62	Flange 2 inch, ANSI B 16.5, 300 lbs RF, 1.4435/316L
A63	Flange 2 inch, ANSI B 16.5, 600 lbs RF, 1.4435/316L
A72	Flange 2-1/2 inch, ANSI B 16.5, 300 lbs RF, 1.4435/316L
A81	Flange 3 inch, ANSI B 16.5, 150 lbs RF, 1.4435/316L
A82	Flange 3 inch, ANSI B 16.5, 300 lbs RF, 1.4435/316L
A91	Flange 4 inch, ANSI B 16.5, 150 lbs RF, 1.4435/316L
A92	Flange 4 inch, ANSI B 16.5, 300 lbs RF, 1.4435/316L
A93	Flange 4 inch, ANSI B 16.5, 600 lbs RF, 1.4435/316L
F45	Flange DN25 PN25/40 A, EN 1092-1, 1.4435/316L
F51	Flange DN32 PN6 A, EN 1092-1, 1.4435/316L
F55	Flange DN32 PN25/40 A, EN 1092-1, 1.4435/316L
F61	Flange DN40 PN6 A, EN 1092-1, 1.4435/316L
F65	Flange DN40 PN25/40 A, EN 1092-1, 1.4435/316L
F71	Flange DN50 PN6 A, EN 1092-1, 1.4435/316L
F75	Flange DN50 PN25/40 A, EN 1092-1, 1.4435/316L
F7F	Flange DN50 PN40 C, EN 1092-1, 1.4435/316L
F81	Flange DN65 PN6 A, EN 1092-1, 1.4435/316L
F85	Flange DN65 PN25/40 A, EN 1092-1, 1.4435/316L
F93	Flange DN80 PN10/16 A, EN 1092-1, 1.4435/316L
F95	Flange DN80 PN25/40 A, EN 1092-1, 1.4435/316L
FA3	Flange DN100 PN10/16 A, EN 1092-1, 1.4435/316L
FA5	Flange DN100 PN25/40 A, EN 1092-1, 1.4435/316L
D45	Flange DN25 PN25/40 B1, EN 1092-1, 1.4435/316L
C45	Flange DN25 PN25/40, EN 1092-1, 2.4610/Alloy C4, 1.4435/316L, platinized
D51	Flange DN32 PN6 B1, EN 1092-1, 1.4435/316L
C51	Flange DN32 PN6, EN 1092-1, 2.4610/Alloy C4, 1.4435/316L, platinized
D71	Flange DN50 PN6 B1, EN 1092-1, 1.4435/316L
C71	Flange DN50 PN6, EN 109platinized2-1, 2.4610/Alloy C4, 1.4435/316L, platinized
D75	Flange DN50 PN25/40 B1, EN 1092-1, 1.4435/316L
C75	Flange DN50 PN25/40, EN 1092-1, 2.4610/Alloy C4, 1.4435/316L, platinized
D95	Flange DN80 PN25/40 B1, EN 1092-1, 1.4435/316L
C95	Flange DN80 PN25/40, EN 1092-1, 2.4610/Alloy C4, 1.4435/316L, platinized
DA3	Flange DN100 PN10/16 B1, EN 1092-1, 1.4435/316L
CA3	Flange DN100 PN10/16, EN 1092-1, 2.4610/Alloy C4, 1.4435/316L, platinized
N75	Flange DN50 PN40 D, EN 1092-1, 1.4435/316L
J13	Flange 10K 25A, JIS B 2238 RF, 1.4435/316L
J16	Flange 10K 40A, JIS B 2238 RF, 1.4435/316L
J17	Flange 10K 50A, JIS B 2238 RF, 1.4435/316L
J1C	Flange 10K 50A, JIS B 2238 RF, 2.4610/Alloy C4, platinized
J19	Flange 10K 80A, JIS B 2238 RF, 1.4435/316L
J1A	Flange 10K 100A, JIS B 2238 RF, 1.4435/316L
R21	Thread R3/4 BSP, DIN 2999, 1.4435/316L
R2C	Thread R3/4 BSP, DIN 2999, 2.4610/Alloy C4, platinized
R31	Thread R1 BSP, DIN 2999, 1.4435/316L
R3C	Thread R1 BSP, DIN 2999, 2.4610/Alloy C4

Release date 2019-05-17 11:18 Date of issue 2019-05-17 270755_eng.xml

Refer to "General Notes Relating to Pepperl+Fuchs Product Information".

Pepperl+Fuchs Group
www.pepperl-fuchs.com

USA: +1 330 486 0002
pa-info@us.pepperl-fuchs.com

Germany: +49 621 776 2222
pa-info@de.pepperl-fuchs.com

Singapore: +65 6779 9091
pa-info@sg.pepperl-fuchs.com

Process connection	
N21	Thread 3/4NPT, ANSI B 1.20.1, 1.4435/316L
N2C	Thread 3/4NPT, ANSI B 1.20.1, 2.4610/Alloy C4
N31	Thread 1 NPT, ANSI B 1.20.1, 1.4435/316L
N3C	Thread 1 NPT, ANSI B 1.20.1, 2.4610/Alloy C4
G21	Thread G3/4A, DIN ISO 228/1, BSP, 1.4435/316L, for mounting with welding sleeve
G2C	Thread G3/4A, DIN ISO 228/1, BSP, 2.4610/Alloy C4
G31	Thread G1A, DIN ISO 228/1, BSP, 1.4435/316L
G3C	Thread G1A, DIN ISO 228/1, BSP, 2.4610/Alloy C4
G3E	Thread G1A, DIN ISO 228/1, BSP, 1.4435/316L, fmounting with welding sleeve
T51	1-1/2 inch, DN25-38, Triclamp ISO 2852 1.4435/316L
T61	2 inch, DN40-51, Triclamp ISO 2852 1.4435/316L
XXX	Special version

Probe version, temperature spacer, flameproof bushing	
BB	in mm L, 1.4435/316L, $R_a < 3.2 \mu\text{m}/80$ grit
BE	in mm L, 2.4610/Alloy C4, $R_a < 3.2 \mu\text{m}/80$ grit
CB	in inch L, 1.4435/316L, $R_a < 3.2 \mu\text{m}/80$ grit
CE	in inch L, 2.4610/Alloy C4, $R_a < 3.2 \mu\text{m}/80$ grit
DB	Special length L II, 1.4435/316L, $R_a < 3.2 \mu\text{m}/80$ grit, switch point = Vibracon compact
DE	Special length L II, 2.4610/Alloy C4, $R_a < 3.2 \mu\text{m}/80$ grit, switch point = Vibracon compact
JB	in mm L, 1.4435/316L, with temperature spacer
JE	in mm L, 2.4610/Alloy C4, with temperature spacer
KB	in inch L, 1.4435/316L, with temperature spacer
KE	in inch L, 2.4610/Alloy C4, with temperature spacer
LB	Special length L II, 1.4435/316L, with temperature spacer, switch point = Vibracon compact
LE	Special length L II, 2.4610/Alloy C4, with temperature spacer, switch point = Vibracon compact
RB	in mm L, 1.4435/316L, with flameproof bushing
RE	in mm L, 2.4610/Alloy C4, with flameproof bushing
SB	in inch L, 1.4435/316L, with flameproof bushing
SE	in inch L, 2.4610/Alloy C4, with flameproof bushing
TB	Special length L II, 1.4435/316L, with flameproof bushing, switch point = Vibracon compact
TE	Special length L II, 2.4610/Alloy C4, with flameproof bushing, switch point = Vibracon compact
XX	Special version

Probe length	
L	Specified length, any length from 148 mm to 3000 mm (up to 6000 mm on request)

Housing	
A1	Aluminium housing, IP66, thread M20
A2	Aluminium housing, NEMA 4X, thread 3/4NPT
A3	Aluminium housing, IP66, entry G1/2A
A4	Aluminium housing, IP66, plug M12 x 1
A5	Aluminium housing, IP66, PA plug M12 x 1
C2	Compact housing, NEMA 4X, 1/2NPT, 1.4435/316L
C4	Compact housing, IP66, plug M12 x 1, 1.4435/316L
C6	Compact housing, IP66, thread PG11, 1.4435/316L
E1	Stainless steel housing, IP66, thread M20
E2	Stainless steel housing, NEMA 4X, thread 1/2NPT
E3	Stainless steel housing, IP66, entry G1/2A
E4	Stainless steel housing, IP66, plug M12 x 1
E5	Stainless steel housing, IP66, PA plug M12 x 1
P1	Polyester housing, IP66, thread M20
P2	Polyester housing, NEMA 4X, thread 1/2NPT
P3	Polyester housing, IP66, entry G1/2A
P4	Polyester housing, IP66, plug M12 x 1
P5	Polyester housing, IP66, PA plug M12 x 1

Electrical connection	
PA	FEL50A, PROFIBUS PA
AC	FEL51, contactless 2-wire switch, 19 V ... 253 V AC
E5	FEL52, PNP 3-wire, 10 V ... 55 V DC
WA	FEL54, potential-free change-over contact, DPDT, 19 V ... 253 V AC, 19 V ... 55 V DC
SI	FEL55, 8/16 mA, 11 V ... 36 V DC
N1	FEL56, NAMUR, L-H edge
N2	FEL58, NAMUR with push button, H-L edge

Release date 2019-05-17 11:18 Date of issue 2019-05-17 270755_eng.xml

Refer to "General Notes Relating to Pepperl+Fuchs Product Information".

Additional equipment	
NA	without additional equipment
Z3	3.1.B material, wetted parts 1.4435, inspection certificate to EN 10204

Approval	
NA	Version for non-hazardous area
WH	WHG overfill protection
E1	ATEX II 1G EEx ia IIC T6
E2	ATEX II 1/2G EEx ia IIC T6
E3	ATEX II 1/2G EEx d IIC T6
EA	ATEX II 1G EEx ia IIC T6, WHG
EB	ATEX II 1/2G EEx ia IIC T6, WHG
EC	ATEX II 1/2G EEx d IIC T6, WHG
EM	ATEX II 3G EEx nA IIC T6, WHG
EN	ATEX II 3G EEx nC IIC T6, WHG
FI	FM IS, Cl. I, II, III, Div. 1, Gr. A-G
FN	FM NI, Cl. I, Div. 2, Gr. A-D
FX	FM XP, Cl. I, II, III, Div. 1, Gr. A-G
CG	CSA General Purpose
CI	CSA IS, Cl. I, II, III, Div. 1, Gr. A-G
CX	CSA XP, Cl. I, II, III, Div. 1, Gr. A-G

Release date 2019-05-17 11:18 Date of issue 2019-05-17 270755_eng.xml

Refer to "General Notes Relating to Pepperl+Fuchs Product Information".