

Features

- Limit switch for bulk solids
- Device with rope probe
- Rope probe can be shortened for optimum matching to the measuring point
- Complete unit consisting of the probe and electronic insert
- Integrated active build-up compensation: exact switch point, even with strong build-up
- Mechanically rugged: no wearing parts, long operating life, maintenance-free

Function

The capacitive limit switch is designed for limit detection of light bulk solids, e. g. grain products, flour, milk powder, animal feed, cement, chalk or plaster.

Versions:

- Device with rope probe up to 6 m (20 feet), for bulk solids
- Relay output (potential-free change-over contact) with AC or DC connection
- PNP output with 3-wire DC connection

Assembly

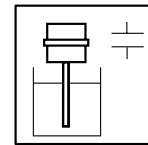
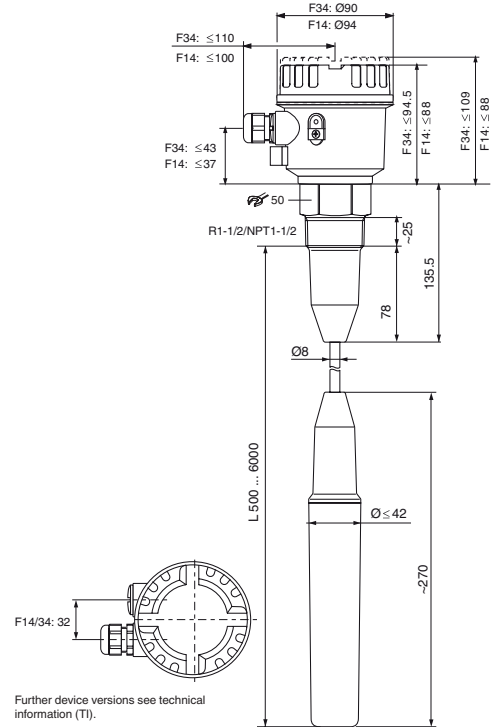

Connection

Connection type E5, 3-wire DC connection (example)

3-wire DC connection

- F: Fine-wire fuse, 500 mA
- R: connected load, e. g. PLC, DCS, relay
- M: Connection to ground, silo or metal parts silo
- E: Grounding

The LCL is protected against reverse polarity. In case of mixing up the connections, the green LED does not illuminate "ready to operate".

PE-connection and PAL-connection for LCL1 are unnecessary.

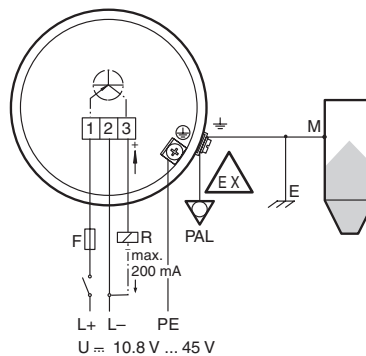

Other connection types see section electrical connection.

Release date 2018-08-14 11:19 Date of issue 2018-08-14 271956_eng.xml

General specifications	
Measuring method	A metal plate at the end of the probe, within the insulation, and the surroundings (e. g. the silo walls) combine to form the two electrodes of a capacitor. If the probe is covered or free of material, then the capacitance changes and the LCL switches.
Equipment architecture	The measuring system consists of: - the device - a supply point - the connected control systems, switching units, signalling systems (e. g. lamps, horns, PCS, PLC, etc.)
Construction type	device rope probe
Operating mode	MAX = maximum safety: The device switches if the probe is covered or if the supply voltage is disconnected in a safety-oriented manner (signal on alarm). example application: overspill protection MIN = minimum safety: The device switches if the probe is uncovered or if the supply voltage is disconnected in a safety-oriented manner (signal on alarm). example application: dry-running protection
Supply	
Rated voltage U_r	electrical connection E5: 10.8 ... 45 V DC, short-term pulse on 55 V DC electrical connection WA: 20 ... 235 V AC, 50/60 Hz or 20 ... 55 V DC
Current consumption	electrical connection E5: max. 30 mA, reverse-polarity-proof electrical connection WA: max. 130 mA
Electrical specifications	
Surge protection	overvoltage category III
Input	
Measured variable	limit level (limit value)
Measurement range	dielectric constant ≥ 1.6
Output	
Switch-on delay t_{on}	correct switching after max. 2 s
Output signal	connection E5: switching PNP, $I_{max} = 200$ mA - overload and short circuit protection - residual voltage at transistor at $I_{max} < 2.9$ V connection WA: contact change-over, potential-free - $U_{max} = 253$ V - $I_{max} = 4$ A (AC) - $P_{max} = 1000$ VA, $\cos \phi = 1$, $P_{max} = 500$ VA, $\cos \phi > 0.7$
Signal on alarm	connection E5: < 100 μ A connection WA: relay de-energized
Directive conformity	
Electromagnetic compatibility	
Directive 2014/30/EU	EN 61326-1:2006 , EN 61326-2-3:2006
Low voltage	
Directive 2014/35/EU	EN 61010-1:2010
Conformity	
Electromagnetic compatibility	NE 21
Degree of protection	IEC 60529:2001
Vibration resistance	EN 60068-2-64
Climate class	EN 60068, part 2-38 (test Z/AD)
Measurement accuracy	
Reference operating conditions	vessel type: plastic vessel, ambient temperature: 73 °F (23 °C, 296 K), medium temperature: 73 °F (23 °C, 296 K) medium pressure p_e : 0 bar, medium: dielectric constant = 2.6, conductivity: < 1 μ S sensitivity setting: C
Hysteresis	vertical 5 mm (0.2 inch)
Long-term drift	vertical 6 mm (0.24 inch)
Influence of medium temperature	depending on the filling material
Switching time	approx. 0.8 s when covering and uncovering the sensor
Operating conditions	
Installation conditions	
Installation position	vertically down
Mounting location	The capacitive limit switch can be installed in silos made of different materials (e. g. metal, plastic, concrete).
Process conditions	
Process temperature	-40 ... 80 °C (-40 ... 176 °F)
Medium pressure limits	-1 ... 6 bar
State of aggregation	solids
Solid contents	$\leq \varnothing 30$ mm
Bulk density	≤ 200 g/l

Release date 2018-08-14 11:19 Date of issue 2018-08-14 271956_eng.xml

Refer to "General Notes Relating to Pepperl+Fuchs Product Information".

Pepperl+Fuchs Group
www.pepperl-fuchs.com

USA: +1 330 486 0002
pa-info@us.pepperl-fuchs.com

Germany: +49 621 776 2222
pa-info@de.pepperl-fuchs.com

Singapore: +65 6779 9091
pa-info@sg.pepperl-fuchs.com

Ambient conditions	
Ambient temperature	-40 ... 80 °C (-40 ... 176 °F) -40 ... 60 °C (-40 ... 140 °F) (Dust-Ex version)
Storage temperature	-40 ... 80 °C (-40 ... 176 °F)
Shock resistance	device with F34 housing: 7 J
Vibration resistance	a(RMS) = 50 m/s ² , ASD = 1.25 (m/s ²) ² /Hz, f = 5 to 2000 Hz, t = 3 x 2 h
Mechanical specifications	
Degree of protection	IP66, NEMA 4
Connection	gland M20 thread G1/2, NPT1/2
Material	F14 housing: polyester PBT-FR F34 housing F34: aluminum Probe: PPS GF40 probe rope: PE-HD probe rope seal: VMQ
Dimensions	max. Ø94 mm (3.7 inch), length 140 mm (5.5 inch) + L L = 500 ... 6000 mm (19.7 ... 236 inch)
Process connection	thread R1-1/2 acc. to EN 10226, BSPT thread NPT1-1/2 to ANSI B 1.20.1
Data for application in connection with hazardous areas	
EU-Type Examination Certificate	see instruction manuals (SI)
Directive conformity	
Directive 2014/34/EU	EN 60079-0:2012+A11:2013 , EN 60079-11:2012 , EN 60079-31:2009
General information	
Supplementary documentation	technical information (TI) manuals, brief instructions (BA, KA) instruction manuals (SI)
Supplementary information	EC-Type Examination Certificate, Statement of Conformity, Declaration of Conformity, Attestation of Conformity and instructions have to be observed where applicable. For information see www.pepperl-fuchs.com .
Accessories	
Optional accessories	LCL-Z10 cover with sight glass for F14 housing LCL-Z14 rope shortening set

Release date 2018-08-14 11:19 Date of issue 2018-08-14 271956_eng.xml

Electrical connection

Electronic insert E5

3-wire DC connection

- F: fine-wire fuse, 500 mA
- R: connected load, e. g. PLC, DCS, relay
- M: connection to ground, silo or metal parts silo
- E: grounding
- E: grounding

The LCL is protected against reverse polarity. In case of mixing up the connections, the green LED does not illuminate "ready to operate".

PE-connection and PAL-connection for LCL1 are unnecessary.

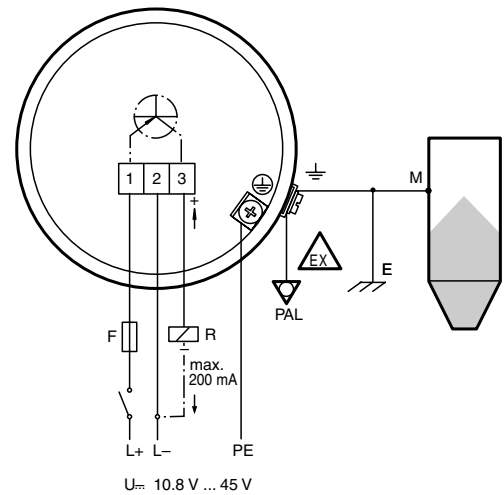

Electronic insert WA

AC/DC connection with relay output

- F1: fine-wire fuse for the protection of the relay contact, dependent on the connected load
- F2: fine-wire fuse, 500 mA
- M: connection to ground, silo or metal parts silo
- E: grounding

PE-connection and PAL-connection for LCL1 are unnecessary.

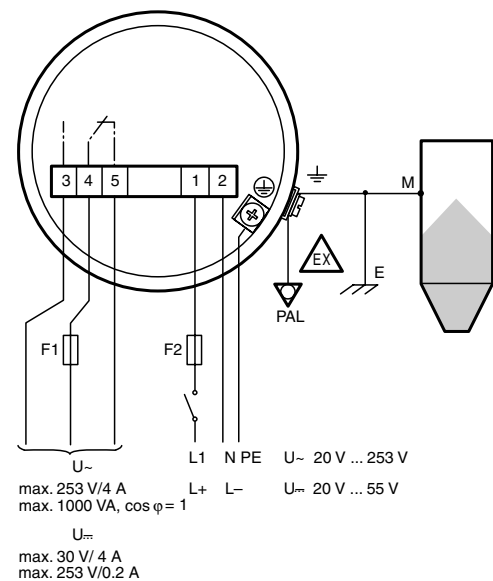

Type Code



*This overview does not mark options which are mutually exclusive.
Option with * = on request/in preparation.*

Device	
LCL	Capacitive limit switch
Design	
2	Device with rope extension
Process connection	
N5	Thread ANSI NPT1-1/2, PPS
R5	Thread EN 10226 R1-1/2, PPS
Probe length	
3	1500 mm (59 inch), steel, HD-PE insulated
4	2500 mm (98 inch), steel, HD-PE insulated
5	4000 mm (157 inch), steel, HD-PE insulated
6	6000 mm (236 inch), steel, HD-PE insulated
I	Specified length in inch, steel, HD-PE insulated, max. 236 inch
X	Specified length in mm, steel, HD-PE insulated, max. 6000 mm
Housing, cable entrance	
C	Polyester housing F14, IP66, NEMA 4, thread NPT1/2
H	Aluminium housing F34, IP66, NEMA 4X, thread NPT1/2
I	Aluminium housing F34, IP66, NEMA 4X, thread G1/2
J	Aluminium housing F34, IP66, NEMA 4X, cable gland M20
P	Polyester housing F14, IP66, NEMA 4, cable gland M20
Q	Polyester housing F14, IP66, NEMA 4, thread G1/2A
Electrical output	
E5	3-wire, PNP, 10.8 V DC ... 45 V DC
WA	Relay, potential-free change-over contact, 20 V AC ... 253 V AC, 20 V DC ... 55 V DC
Additional equipment	
N	Without additional equipment
D	Cover with sight glass
Approval	
NA	Version for non-hazardous area
CS	CSA, DIP Cl.II, Gr.E-G, Cl.III
CG	CSA General Purpose
EX	ATEX II 1/3 D Ex tc [ja Da] IIIC T108°C Dc
FS	FM, DIP Cl.II,III, Gr.E-G, T5
WH	Overspill protection WHG

Release date 2018-08-14 11:19 Date of issue 2018-08-14 271956_eng.xml

Refer to "General Notes Relating to Pepperl+Fuchs Product Information".

Pepperl+Fuchs Group
www.pepperl-fuchs.com

USA: +1 330 486 0002
pa-info@us.pepperl-fuchs.com

Germany: +49 621 776 2222
pa-info@de.pepperl-fuchs.com

Singapore: +65 6779 9091
pa-info@sg.pepperl-fuchs.com