



Photoelectric sensors  
G6, Photoelectric retro-reflective sensor,  
Standard optics

GL6-P0111S09



**Model Name** > **GL6-P0111S09**  
**Part No.** > **1058698**



*Illustration may differ*

**At a glance**

- PinPoint LED for a bright, precise light spot
- Durable metal threaded inserts
- SICK ASIC technology - the result of decades of experience in photoelectric sensors
- Large, user-friendly potentiometer
- Large, bright indicator LEDs
- IP 67 enclosure rating

**Your benefits**

- Easy alignment and precise object detection due to a highly visible PinPoint LED
- Quick and easy mounting and high durability due to threaded metal inserts
- SICK ASIC technology provides high performance, excellent reliability and crosstalk immunity
- Easy to adjust due to large, user-friendly potentiometers
- Easy to monitor due to large, bright indicator LEDs
- Easy installation with SICK accessories



**Features**

Sensor/detection principle:	Photoelectric retro-reflective sensor, Standard optics
Dimensions (W x H x D):	12 mm x 31.5 mm x 21 mm
Housing design (light emission):	Rectangular
Sensing range max.:	≤ 6 m <sup>1)</sup>
Sensing range:	≤ 5 m <sup>2)</sup>
Type of light:	Visible red light
Light source:	PinPoint LED <sup>3)</sup>
Wave length:	650 nm
Light spot size (distance):	Ø 8 mm (350 mm)

<sup>1) 2)</sup> PL80A <sup>3)</sup> Average service life of 100,000 h at T<sub>A</sub> = +25 °C

**Mechanics/electronics**

Supply voltage:	10 V DC ... 30 V DC <sup>1)</sup>
Power consumption:	≤ 30 mA <sup>2)</sup>
Output type:	PNP
Switching mode:	Light/dark-switching
Switching mode selector:	Selectable via light/dark selector

Signal voltage PNP HIGH/LOW:	VS - ( $\leq 3$ V)/approx. 0 V
Output current I <sub>max</sub> ..:	$\leq 100$ mA <sup>3)</sup>
Response time:	$< 625$ $\mu$ s <sup>4)</sup>
Switching frequency:	1,000 Hz <sup>5)</sup>
Connection type:	Cable with Tyco connector, 550 mm <sup>6)</sup>
Cable material:	PVC
Conductor cross-section:	0.14 mm <sup>2</sup>
Circuit protection:::	A, B, D <sup>7) 8) 9)</sup>
Weight:	60 g
Polarisation filter:	✓
AS-Interface-Chip:	-
Housing material:	ABS/PC, Plastic
Optics material:	PMMA
Enclosure rating:	IP 67
Ambient operating temperature:	-25 °C ... 55 °C
Ambient storage temperature:	-40 °C ... 70 °C

1) Limit values, operation in short-circuit protected network max. 8 A 2) Without load 3) At Vs > 24 V, I<sub>A</sub> max = 50 mA 4) Signal transit time with resistive load 5) With light/dark ratio 1:1 6) Do not bend below 0 °C 7) A = V<sub>S</sub> connections reverse-polarity protected 8) B = inputs and output reverse-polarity protected 9) D = outputs overcurrent and short-circuit protected

## Dimensional drawing

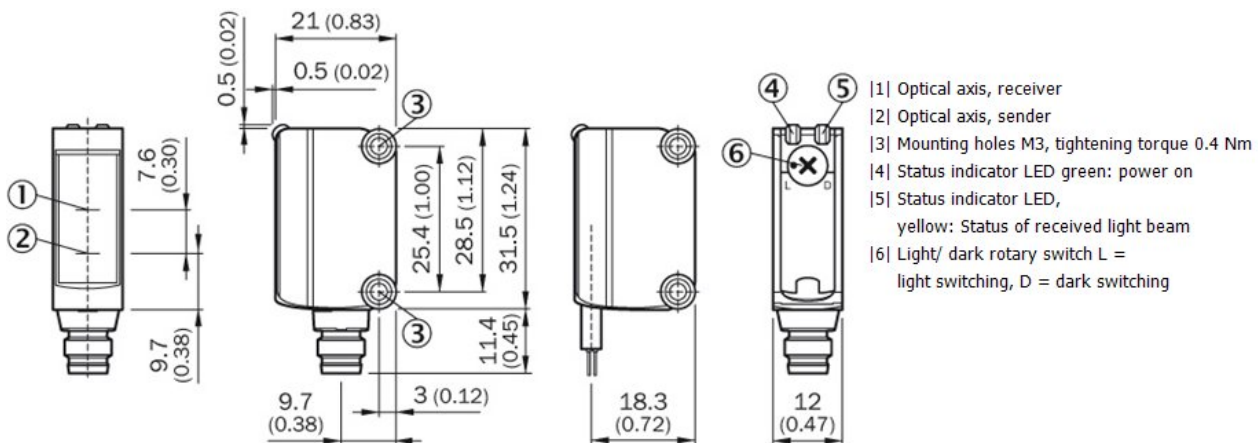

**Adjustments possible**

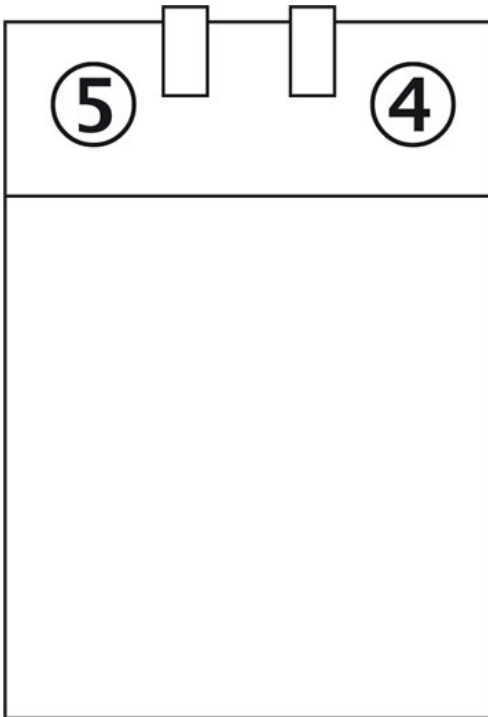

- |4| Status indicator LED green: power on
- |5| Status indicator LED, yellow: Status of received light beam

**Characteristic curve**

Operating reserve

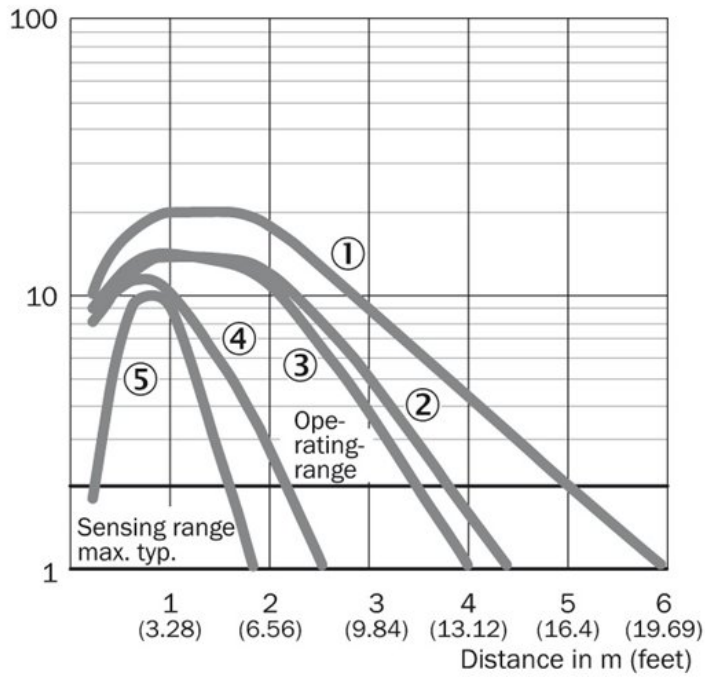

- |1| PL80A
- |2| PL40A
- |3| P250
- |4| PL20A
- |5| REF-IRF-56

### Sensing range diagram

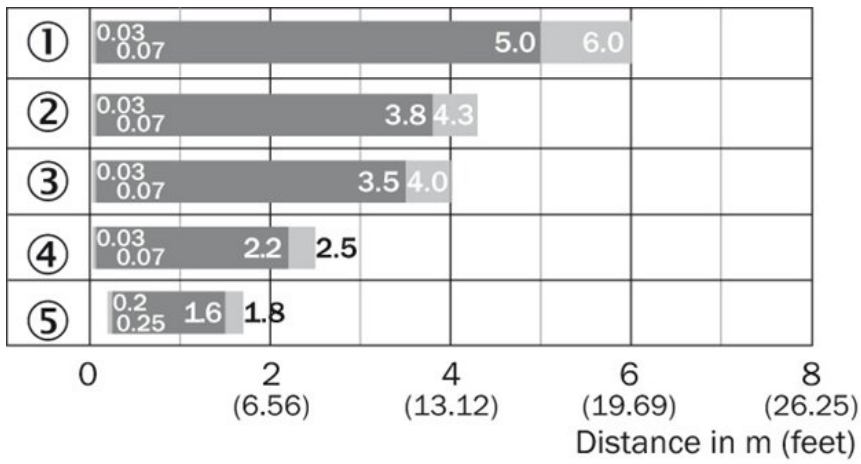

Sensing range     
  Sensing range max.

### Light spot size

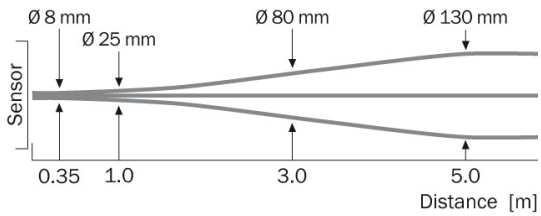

**Australia**

Phone +61 3 9457 0600  
1800 334 802 – tollfree  
E-Mail sales@sick.com.au

**Belgium/Luxembourg**

Phone +32 (0)2 466 55 66  
E-Mail info@sick.be

**Brasil**

Phone +55 11 3215-4900  
E-Mail sac@sick.com.br

**Canada**

Phone +1 905 771 14 44  
E-Mail information@sick.com

**Ceská Republika**

Phone +420 2 57 91 18 50  
E-Mail sick@sick.cz

**China**

Phone +86 4000 121 000  
E-Mail info.china@sick.net.cn  
Phone +852-2153 6300  
E-Mail ghk@sick.com.hk

**Danmark**

Phone +45 45 82 64 00  
E-Mail sick@sick.dk

**Deutschland**

Phone +49 211 5301-301  
E-Mail kundenservice@sick.de

**España**

Phone +34 93 480 31 00  
E-Mail info@sick.es

**France**

Phone +33 1 64 62 35 00  
E-Mail info@sick.fr

**Great Britain**

Phone +44 (0)1727 831121  
E-Mail info@sick.co.uk

**India**

Phone +91-22-4033 8333  
E-Mail info@sick-india.com

**Israel**

Phone +972-4-6801000  
E-Mail info@sick-sensors.com

**Italia**

Phone +39 02 27 43 41  
E-Mail info@sick.it

**Japan**

Phone +81 (0)3 3358 1341  
E-Mail support@sick.jp

**Magyarország**

Phone +36 1 371 2680  
E-Mail office@sick.hu

**Nederlands**

Phone +31 (0)30 229 25 44  
E-Mail info@sick.nl

**Norge**

Phone +47 67 81 50 00  
E-Mail austefjord@sick.no

**Österreich**

Phone +43 (0)22 36 62 28 8-0  
E-Mail office@sick.at

**Polska**

Phone +48 22 837 40 50  
E-Mail info@sick.pl

**România**

Phone +40 356 171 120  
E-Mail office@sick.ro

**Russia**

Phone +7-495-775-05-30  
E-Mail info@sick.ru

**Schweiz**

Phone +41 41 619 29 39  
E-Mail contact@sick.ch

**Singapore**

Phone +65 6744 3732  
E-Mail admin@sicksgp.com.sg

**Slovenija**

Phone +386 (0)1-47 69 990  
E-Mail office@sick.si

**South Africa**

Phone +27 11 472 3733  
E-Mail info@sickautomation.co.za

**South Korea**

Phone +82 2 786 6321/4  
E-Mail info@sickkorea.net

**Suomi**

Phone +358-9-25 15 800  
E-Mail sick@sick.fi

**Sverige**

Phone +46 10 110 10 00  
E-Mail info@sick.se

**Taiwan**

Phone +886-2-2375-6288  
E-Mail sales@sick.com.tw

**Türkiye**

Phone +90 (216) 528 50 00  
E-Mail info@sick.com.tr

**United Arab Emirates**

Phone +971 (0) 4 8865 878  
E-Mail info@sick.ae

**USA/México**

Phone +1(952) 941-6780  
1 800-325-7425 – tollfree  
E-Mail info@sickusa.com

More representatives and agencies  
at [www.sick.com](http://www.sick.com)