



Photoelectric sensors
V12-2, Photoelectric proximity sensor, energetic

VT12T-2P410



Model Name > **VT12T-2P410**
Part No. > **6026212**



Illustration may differ

At a glance

- Sensing distance up to 115 mm or 340 mm (90% remission)
- 2 teach-in modes: Standard teach mode for basic applications, precise teach mode with small hysteresis for special applications
- Adjustable light or dark switching as complementary outputs
- PNP or NPN output available
- Complements inductive sensor portfolio
- M12 housing
- 4-pin M12 connector or 2 m cable

Your benefits

- Standard M12 miniature housing saves installation space on the machine
- Simple design and time-saving installation due to a standard M12 housing
- Operating reserve display simplifies commissioning and saves maintenance time
- Cost-effective solution due to simple mounting, standardized connection technology and broad application use
- Fast response times ensure reliable detection of objects at high speeds, increasing machine throughput
- Tough metal housing provides a long service life, reducing maintenance time and costs



Features

Sensor/detection principle:	Photoelectric proximity sensor, energetic
Housing design (light emission):	Cylindrical, straight
Housing length:	65.5 mm
Thread diameter (housing):	M12 x 1
Sensing range max.:	0 mm ... 115 mm ¹⁾
Sensing range:	2 mm ... 100 mm
Type of light:	Infrared light
Light source:	LED ²⁾
Light spot (distance):	20 mm (100 mm)
Wave length:	880 nm
Sensitivity adjustment:	Manual, via teach-in button electronic, via control input C (0 V)
Angle of dispersion:	11.4 °

¹⁾ Object with 90 % reflectance (referred to standard white DIN 5033) ²⁾ Average service life of 100,000 h at T_A = +25 °C

Mechanics/electronics

Supply voltage:	10 V DC ... 30 ¹⁾
Ripple:	≤ 10 % ²⁾
Power consumption:	20 ³⁾
Output type:	PNP, Light/dark-switching, Selectable via control input C
Output current I _{max.} :	100 ⁴⁾
Response time:	≤ 1.25 ms ⁵⁾
Switching frequency:	400 ⁶⁾
Connection type:	Connector M12, 4-pin
Circuit protection:::	A, B, C, D ^{7) 8) 9) 10)}
Protection class:	III
Weight:	18 g
Housing material:	Nickel-plated brass/PA
Optics material:	PMMA
Enclosure rating:	IP 67
Ambient operating temperature:	-25 ... 70 °C
Ambient storage temperature:	-25 ... 70 °C

¹⁾ Limit values ²⁾ May not exceed or fall short of V_S tolerances ^{3) 4)} Without load ⁵⁾ Signal transit time with resistive load ⁶⁾ With light/dark ratio 1:1 ⁷⁾ A = V_S
 connections reverse-polarity protected ⁸⁾ B = inputs and output reverse-polarity protected ⁹⁾ C = interference suppression ¹⁰⁾ D = outputs overcurrent and short-circuit protected

Dimensional drawing

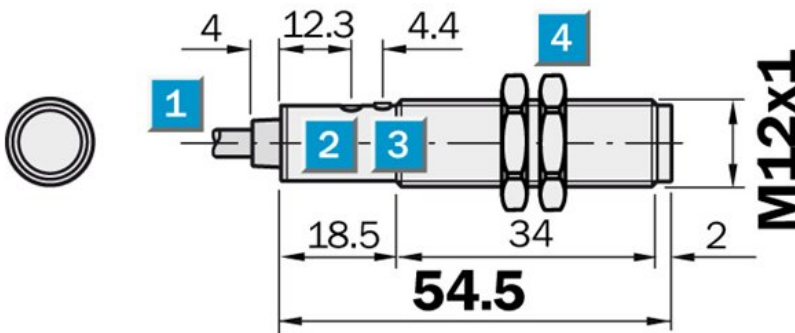

- [1] Cable or connector M12, 4-pin
- [2] Sensitivity setting; single teach button
- [3] Yellow LED indicator:- lights continuously:reception signal> reserve factor 2- b links: Reception signal< reserve factor 2 but > switching
- [4] fastening nuts (2 x); width across 17, metal

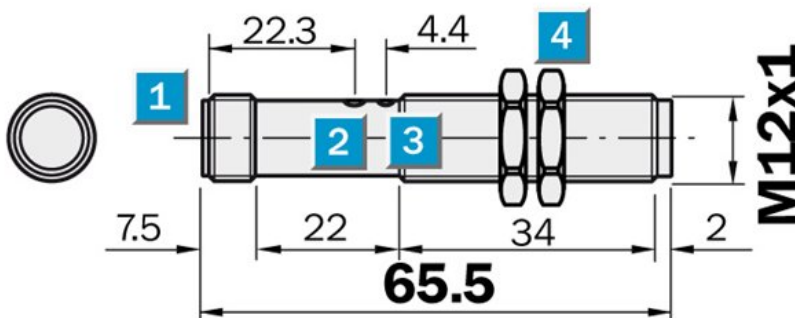

Adjustments possible

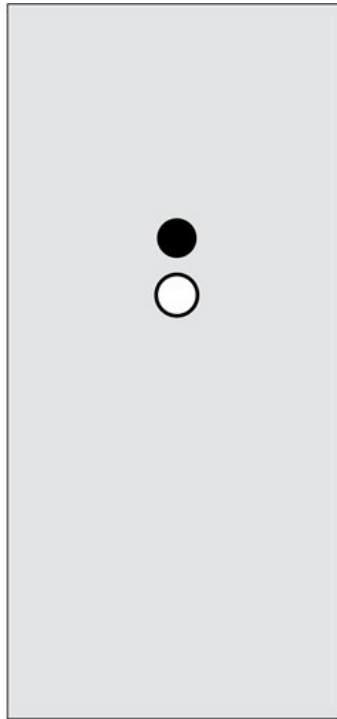

Connection diagram

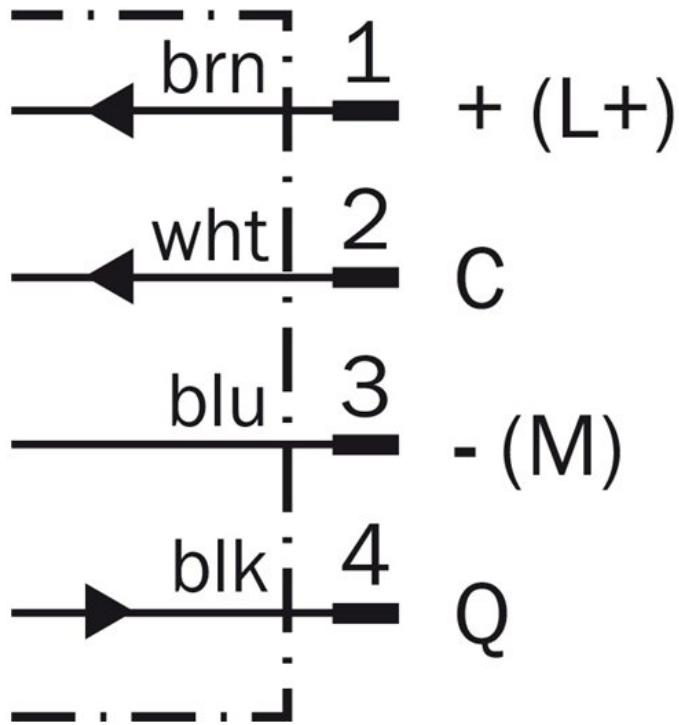

Characteristic curve

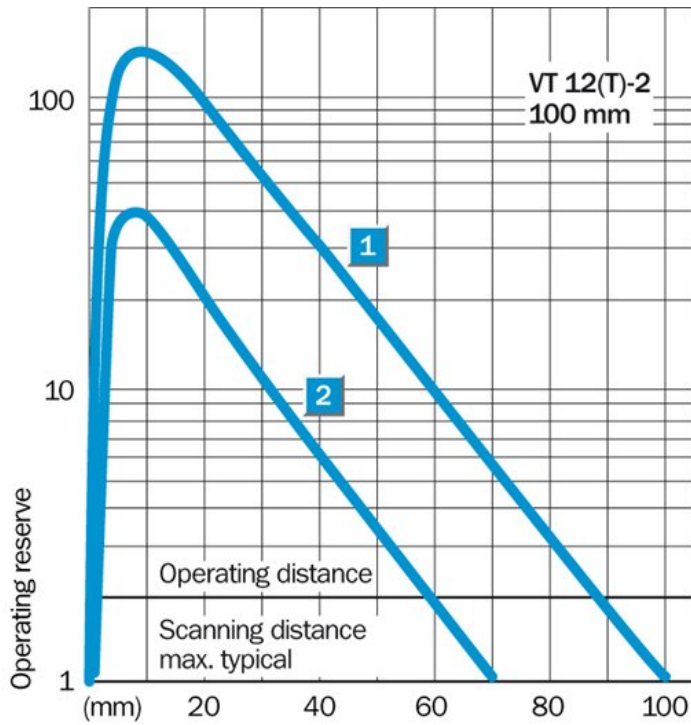

Connection type



Sensing range diagram

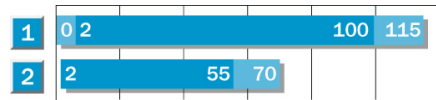

0 (mm) 20 40 60 80 100 120

■ Operating distance ■ Scanning distance, max. typical

1	Scanning distance on white, 90 % remission
2	Scanning distance on grey, 18 % remission

Australia

Phone +61 3 9457 0600
1800 334 802 – tollfree
E-Mail sales@sick.com.au

Belgium/Luxembourg

Phone +32 (0)2 466 55 66
E-Mail info@sick.be

Brasil

Phone +55 11 3215-4900
E-Mail sac@sick.com.br

Canada

Phone +1 905 771 14 44
E-Mail information@sick.com

Ceská Republika

Phone +420 2 57 91 18 50
E-Mail sick@sick.cz

China

Phone +86 4000 121 000
E-Mail info.china@sick.net.cn
Phone +852-2153 6300
E-Mail ghk@sick.com.hk

Danmark

Phone +45 45 82 64 00
E-Mail sick@sick.dk

Deutschland

Phone +49 211 5301-301
E-Mail kundenservice@sick.de

España

Phone +34 93 480 31 00
E-Mail info@sick.es

France

Phone +33 1 64 62 35 00
E-Mail info@sick.fr

Great Britain

Phone +44 (0)1727 831121
E-Mail info@sick.co.uk

India

Phone +91-22-4033 8333
E-Mail info@sick-india.com

Israel

Phone +972-4-6801000
E-Mail info@sick-sensors.com

Italia

Phone +39 02 27 43 41
E-Mail info@sick.it

Japan

Phone +81 (0)3 3358 1341
E-Mail support@sick.jp

Magyarország

Phone +36 1 371 2680
E-Mail office@sick.hu

Nederlands

Phone +31 (0)30 229 25 44
E-Mail info@sick.nl

Norge

Phone +47 67 81 50 00
E-Mail austefjord@sick.no

Österreich

Phone +43 (0)22 36 62 28 8-0
E-Mail office@sick.at

Polska

Phone +48 22 837 40 50
E-Mail info@sick.pl

România

Phone +40 356 171 120
E-Mail office@sick.ro

Russia

Phone +7-495-775-05-30
E-Mail info@sick.ru

Schweiz

Phone +41 41 619 29 39
E-Mail contact@sick.ch

Singapore

Phone +65 6744 3732
E-Mail admin@sicksgp.com.sg

Slovenija

Phone +386 (0)1-47 69 990
E-Mail office@sick.si

South Africa

Phone +27 11 472 3733
E-Mail info@sickautomation.co.za

South Korea

Phone +82 2 786 6321/4
E-Mail info@sickkorea.net

Suomi

Phone +358-9-25 15 800
E-Mail sick@sick.fi

Sverige

Phone +46 10 110 10 00
E-Mail info@sick.se

Taiwan

Phone +886-2-2375-6288
E-Mail sales@sick.com.tw

Türkiye

Phone +90 (216) 528 50 00
E-Mail info@sick.com.tr

United Arab Emirates

Phone +971 (0) 4 8865 878
E-Mail info@sick.ae

USA/México

Phone +1(952) 941-6780
1 800-325-7425 – tollfree
E-Mail info@sickusa.com

More representatives and agencies
at www.sick.com