



Inductive proximity sensors
Rectangular housing, IQ08

IQ08-02BN0KW2S



Model Name > [IQ08-02BNOKW2S](#)
Part No. > [1055493](#)



At a glance

- Tough VISTALTM housing
- SICK-ASIC technology
- 270° status display with extra-bright LED
- Extended sensing range of up to 4 mm
- Hotmelt molding
- Threaded metal inserts
- IP 68 enclosure rating

Your benefits

- Best mechanical and electronic stability for extra-long service life
- Highest levels of process reliability for your application
- Long service life that reduce maintenance costs thanks to SICK's ASIC technology and rugged VISTALTM housing
- Precise detection and high sensor accuracy enable fast handling and assembly processes
- Space-saving integration in every application
- Increased levels of protection against shock and vibration reduce maintenance costs
- Quick viewing of sensor status from any position in the room reduces mounting time and commissioning
- Safe, fast mounting without any need for readjustment saves installation time and maintenance costs



Features

Housing:	Rectangular
Dimensions (W x H x D):	8 mm x 8 mm x 40 mm
Sensing range Sn:	2 mm
Assured sensing range Sa:	1.62 mm
Installation type:	Flush
Switching frequency:	2,000 Hz
Output type:	NPN
Output function:	NC
Electrical wiring:	DC 3-wire
Enclosure rating:	IP 67 ¹⁾ IP 68
Connection type:	Cable, 3-wire, 2 m

1) According to EN 60529

Mechanics/electronics

Supply voltage:	10 V DC ... 30 V DC
Ripple:	$\leq 10\%$ ¹⁾
Voltage drop:	$\leq 2\text{ V}$ ²⁾
Power consumption:	$\leq 10\text{ mA}$ ³⁾
Time delay before availability:	$\leq 100\text{ ms}$
Hysteresis:	5 % ... 15 %
Repeatability:	$\leq 2\%$ ^{4) 5)}
Temperature drift (% of Sr):	$\pm 10\%$
EMC:	According to EN 60947-5-2
Output current I _a :	$\leq 200\text{ mA}$
Cable material:	PVC
Conductor cross-section:	0.14 mm ²
Cable diameter:	Ø 2.9 mm
Short-circuit protection:	✓
Reverse polarity protection:	✓
Power-up pulse protection:	✓
Shock/vibration:	30 g, 11 ms/10 ... 55 Hz, 1 mm
Ambient operating temperature:	-25 °C ... 75 °C
Housing material:	Plastic, VISTAL
Sensing face material:	Plastic, VISTAL
Tightening torque, max.:	$\leq 1.5\text{ Nm}$

1) Of V_S ²⁾ At I_a max ³⁾ Without load ⁴⁾ U_b and T_a constant ⁵⁾ Of Sr

Reduction factors

Note:	The values are reference values which may vary
Stainless steel (V2A, 304):	0.7
Copper (Cu):	0.2
Aluminum (Al):	0.3
Brass (Br):	0.3

Installation note

A:	0 mm
B:	10 mm
C:	8 mm
D:	6 mm
E:	0 mm
F:	16 mm
G:	0 mm
Remark:	Associated graphic see "Installation"

Installation note

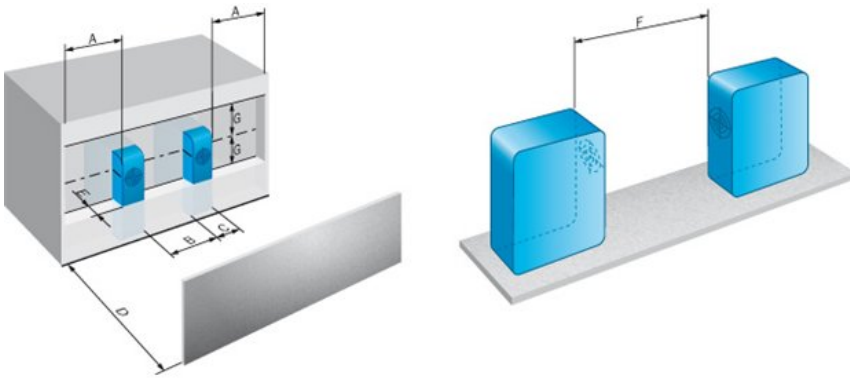

Dimensional drawing

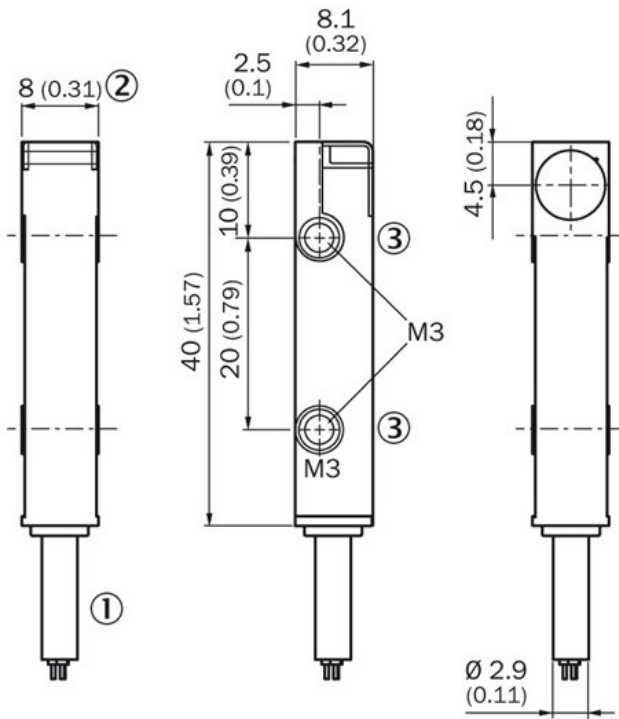

- |1| Connection
- |2| LED indicator 270°
- |3| Threaded mounting hole M3

Connection diagram

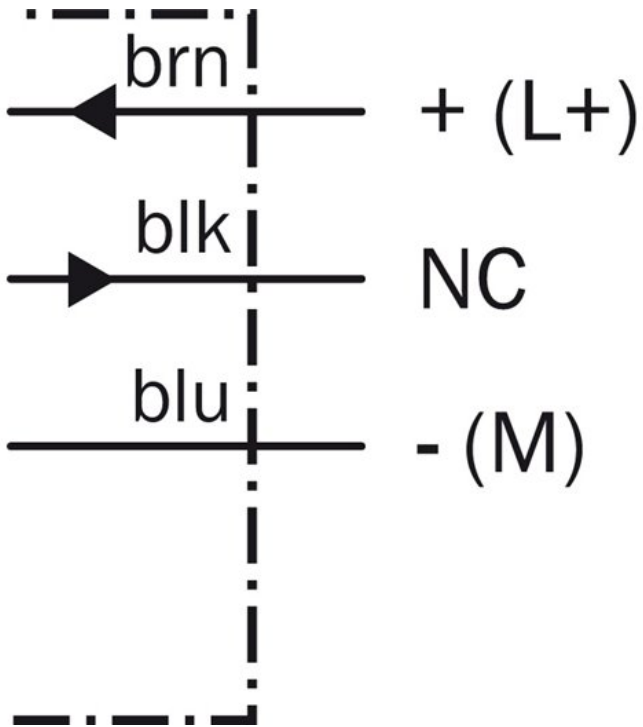

Australia

Phone +61 3 9457 0600
1800 334 802 – tollfree
E-Mail sales@sick.com.au

Belgium/Luxembourg

Phone +32 (0)2 466 55 66
E-Mail info@sick.be

Brasil

Phone +55 11 3215-4900
E-Mail sac@sick.com.br

Canada

Phone +1 905 771 14 44
E-Mail information@sick.com

Ceská Republika

Phone +420 2 57 91 18 50
E-Mail sick@sick.cz

China

Phone +86 4000 121 000
E-Mail info.china@sick.net.cn
Phone +852-2153 6300
E-Mail ghk@sick.com.hk

Danmark

Phone +45 45 82 64 00
E-Mail sick@sick.dk

Deutschland

Phone +49 211 5301-301
E-Mail kundenservice@sick.de

España

Phone +34 93 480 31 00
E-Mail info@sick.es

France

Phone +33 1 64 62 35 00
E-Mail info@sick.fr

Great Britain

Phone +44 (0)1727 831121
E-Mail info@sick.co.uk

India

Phone +91-22-4033 8333
E-Mail info@sick-india.com

Israel

Phone +972-4-6801000
E-Mail info@sick-sensors.com

Italia

Phone +39 02 27 43 41
E-Mail info@sick.it

Japan

Phone +81 (0)3 3358 1341
E-Mail support@sick.jp

Magyarország

Phone +36 1 371 2680
E-Mail office@sick.hu

Nederlands

Phone +31 (0)30 229 25 44
E-Mail info@sick.nl

Norge

Phone +47 67 81 50 00
E-Mail austefjord@sick.no

Österreich

Phone +43 (0)22 36 62 28 8-0
E-Mail office@sick.at

Polska

Phone +48 22 837 40 50
E-Mail info@sick.pl

România

Phone +40 356 171 120
E-Mail office@sick.ro

Russia

Phone +7-495-775-05-30
E-Mail info@sick.ru

Schweiz

Phone +41 41 619 29 39
E-Mail contact@sick.ch

Singapore

Phone +65 6744 3732
E-Mail admin@sicksgp.com.sg

Slovenija

Phone +386 (0)1-47 69 990
E-Mail office@sick.si

South Africa

Phone +27 11 472 3733
E-Mail info@sickautomation.co.za

South Korea

Phone +82 2 786 6321/4
E-Mail info@sickkorea.net

Suomi

Phone +358-9-25 15 800
E-Mail sick@sick.fi

Sverige

Phone +46 10 110 10 00
E-Mail info@sick.se

Taiwan

Phone +886-2-2375-6288
E-Mail sales@sick.com.tw

Türkiye

Phone +90 (216) 528 50 00
E-Mail info@sick.com.tr

United Arab Emirates

Phone +971 (0) 4 8865 878
E-Mail info@sick.ae

USA/México

Phone +1(952) 941-6780
1 800-325-7425 – tollfree
E-Mail info@sickusa.com

More representatives and agencies
at www.sick.com