



Short range distance sensors (displacement)  
OD Value, 4 mA ... 20 mA (&#8804; 300 &#937;)

OD2-P85W2010



**Model Name** > **OD2-P85W2010**  
**Part No.** > **6036613**



**At a glance**

- Several measurement ranges from 26 mm ... 34 mm to 100 mm ... 500 mm
- CMOS receiving element for measurement independent of surface
- Easy, LED-based user and teach-in concept
- Wide range of models and a wide range of standard interfaces
- Laser technology for precise measurement of very small objects
- Compact stand-alone device
- Excellent price-performance ratio

**Your benefits**

- Reliable measurement independent of surface, minimizes machine downtime
- Extremely simple sensor teach-in makes setup faster and more costeffective
- Minimal space requirements and less wiring due to its compact, standalone design
- Many measurement ranges and output interfaces make it ideal for cost-effective integration into any production environment
- Low investment costs make consistent, regular quality inspection possible
- Non-contact measurement technology from a safe distance allows the inspection to be carried out directly during the production process
- Wear and damage-free inspection, due to non-contact measurement

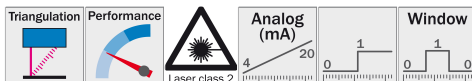

**Performance**

Measuring range:	65 mm ... 105 mm, 6 % ... 90 % remission
Resolution:	10 $\mu\text{m}$ <sup>1)</sup>
Repeatability:::	30 $\mu\text{m}$ <sup>2) 3) 4) 5)</sup>
Linearity:::	$\pm 40 \mu\text{m}$ <sup>6) 7) 8) 9)</sup>
Response time <sup>10)</sup> :	1 ms/10 ms/35 ms
Measuring frequency:	2 kHz
Light source:	Laser, red
Typ. light spot size (distance):	0.8 mm x 1.3 mm (85 mm)
Additional function:	Automatic sensitivity adjustment, Teach-in of analog outputs, Teach-in of switching output, Invertable analog output, Invertable switching output, Averaging 1 ... 64x, Multifunctional input: laser-off/external teach-in/trigger, Switching mode: distance to object (DtO), Switching mode: window (Wnd)
Laser class:	2 (EN 60825-1) <sup>11)</sup>

1) 3) 6) At averaging function medium 2) 6 % ... 90 % remission 4) Constant ambient conditions 5) 8) For best performance consider warm up time  $\leq 5$  minutes 7)  
 Measurement on 90 % remission (ceramic, white) 9) When calibrated in the application regularly 10) Automatic sensitivity adjustment  $\leq 4$  ms, 6 ms for the models with  
 measuring range of 100 mm ... 400 mm 11) Wavelength: 655 nm, max. output: 1 mW

## Interfaces

Data interface: 4 mA ... 20 mA ( $\leq 300 \Omega$ )  
 Output type <sup>1)</sup>: 2 x PNP (100 mA)  
 Multifunctional input (MF) <sup>2)</sup>: 1 x MF

<sup>1)</sup> PNP: HIGH =  $V_S - (< 2 V)$ /LOW =  $< 2 V$ ; NPN: HIGH =  $< 2 V$ /LOW =  $V_S$  <sup>2)</sup> MF can be used as laser-off, trigger, external teach-in or deactivated; response time  $\leq 3$  ms

## Mechanics/electronics

Connection type: Connector, M12, 8-pin  
 Supply voltage  $V_S$  <sup>1)</sup>: DC 12 V ... 24 V  
 Power consumption <sup>2)</sup>:  $\leq 2.88 W$   
 Warm-up time:  $\leq 5$  min  
 Indication: Distance bar graph, up to 8 status LEDs  
 Weight: 70 g  
 Housing material: PBT housing with PMMA lens

<sup>1)</sup> DC 12 V (-5 %) ... 24 V (+10 %); DC 18 V (-5 %) ... DC 24 V (+10 %) when using analog voltage output <sup>2)</sup> Without load, with current output

## Ambient data

Enclosure rating: IP 67  
 Protection class: III  
 Ambient temperature: Operation:  $-10 \dots 40 \text{ }^\circ\text{C}$ , Storage:  $-20 \dots 60 \text{ }^\circ\text{C}$   
 Temperature drift:  $\pm 0.08 \text{ } \%$  FS/K (FS = Full Scale = Measuring range of sensor)  
 Typ. ambient light safety: Artificial light:  $\leq 3,000 \text{ lx}$   
 Sunlight:  $\leq 10,000 \text{ lx}$   
 Vibration resistance: 10 Hz ... 55 Hz (amplitude 1.5 mm, x-, y-, z-axis 2 hours each)  
 Shock resistance: 50 G (x-, y-, z-axis 3 times each)  
 Relative humidity (not condensing): 35 % ... 95 %

## Dimensional drawing

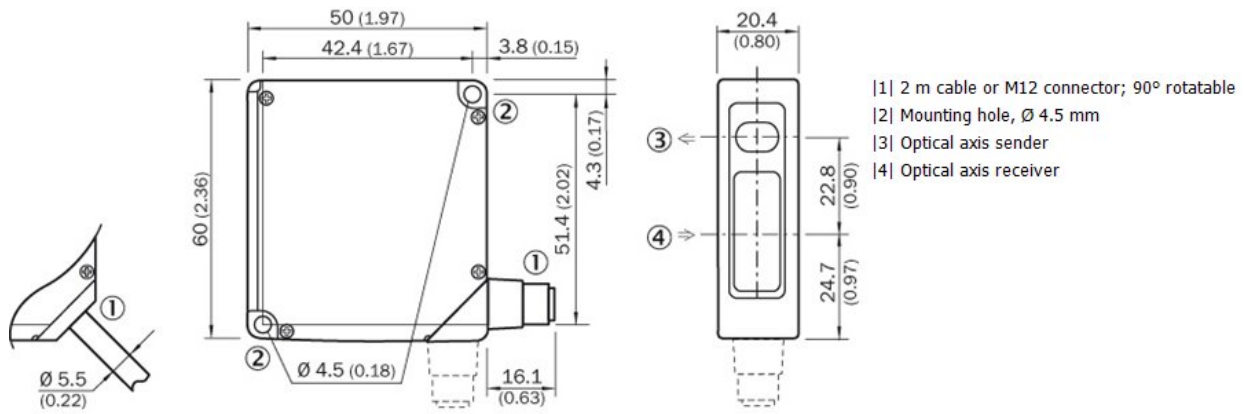

## Adjustment possible

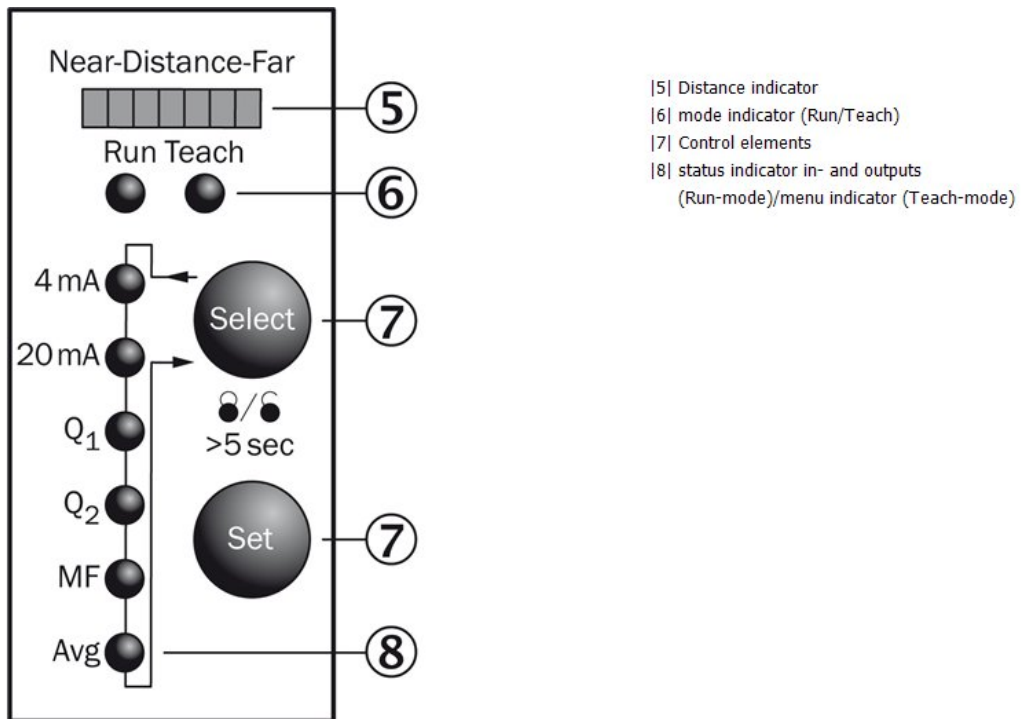

## Connection type

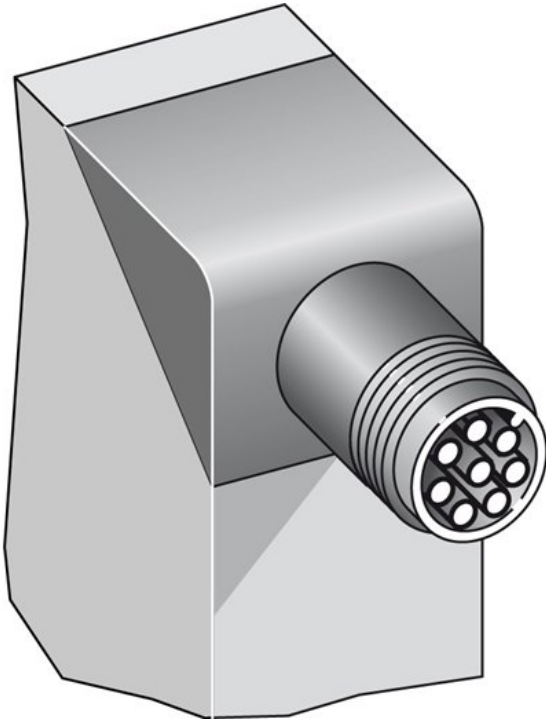

## Connection diagram

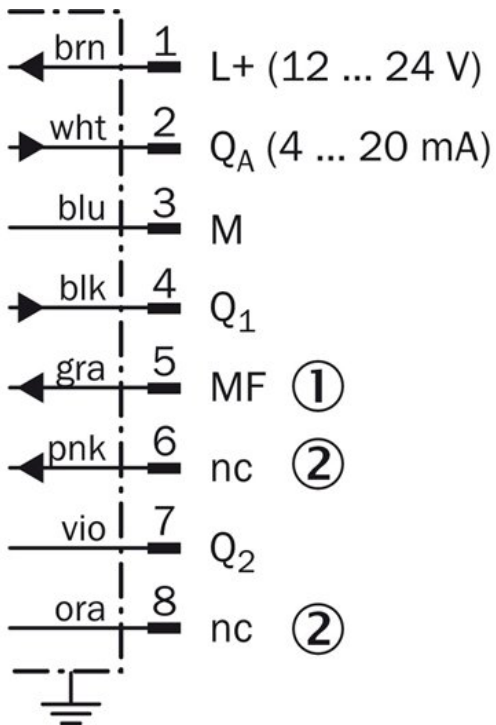

① Multifunctional input (MF)  
② not connected

## Light spot size

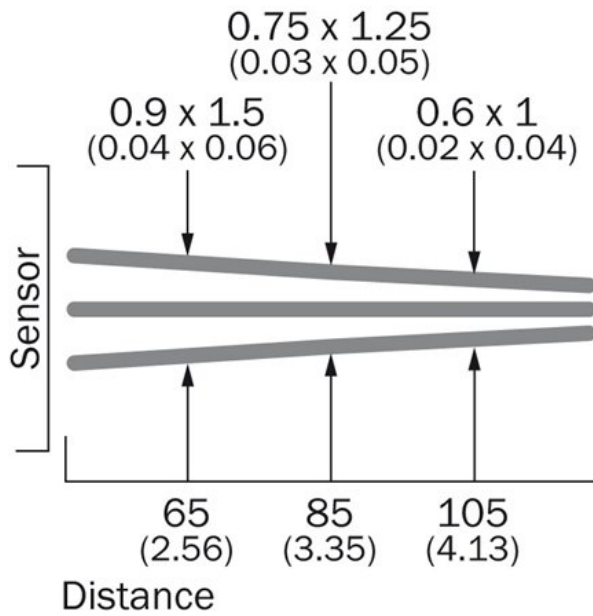

All dimensions in mm (inch)

## Linearity

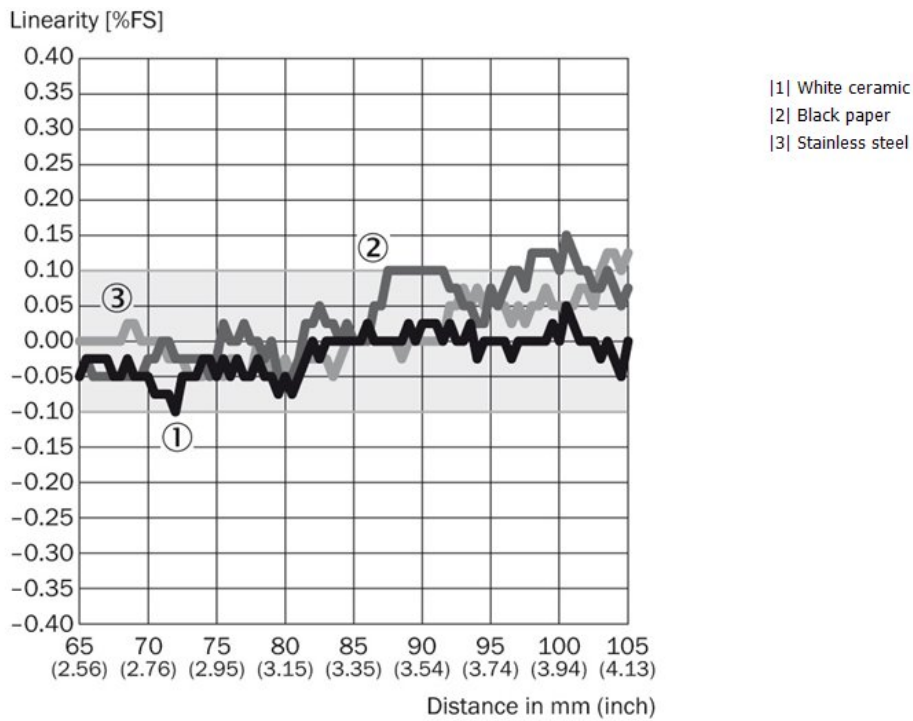

**Australia**

Phone +61 3 9457 0600  
1800 334 802 – tollfree  
E-Mail sales@sick.com.au

**Belgium/Luxembourg**

Phone +32 (0)2 466 55 66  
E-Mail info@sick.be

**Brasil**

Phone +55 11 3215-4900  
E-Mail sac@sick.com.br

**Canada**

Phone +1 905 771 14 44  
E-Mail information@sick.com

**Ceská Republika**

Phone +420 2 57 91 18 50  
E-Mail sick@sick.cz

**China**

Phone +86 4000 121 000  
E-Mail info.china@sick.net.cn  
Phone +852-2153 6300  
E-Mail ghk@sick.com.hk

**Danmark**

Phone +45 45 82 64 00  
E-Mail sick@sick.dk

**Deutschland**

Phone +49 211 5301-301  
E-Mail kundenservice@sick.de

**España**

Phone +34 93 480 31 00  
E-Mail info@sick.es

**France**

Phone +33 1 64 62 35 00  
E-Mail info@sick.fr

**Great Britain**

Phone +44 (0)1727 831121  
E-Mail info@sick.co.uk

**India**

Phone +91-22-4033 8333  
E-Mail info@sick-india.com

**Israel**

Phone +972-4-6801000  
E-Mail info@sick-sensors.com

**Italia**

Phone +39 02 27 43 41  
E-Mail info@sick.it

**Japan**

Phone +81 (0)3 3358 1341  
E-Mail support@sick.jp

**Magyarország**

Phone +36 1 371 2680  
E-Mail office@sick.hu

**Nederlands**

Phone +31 (0)30 229 25 44  
E-Mail info@sick.nl

**Norge**

Phone +47 67 81 50 00  
E-Mail austefjord@sick.no

**Österreich**

Phone +43 (0)22 36 62 28 8-0  
E-Mail office@sick.at

**Polska**

Phone +48 22 837 40 50  
E-Mail info@sick.pl

**România**

Phone +40 356 171 120  
E-Mail office@sick.ro

**Russia**

Phone +7-495-775-05-30  
E-Mail info@sick.ru

**Schweiz**

Phone +41 41 619 29 39  
E-Mail contact@sick.ch

**Singapore**

Phone +65 6744 3732  
E-Mail admin@sicksgp.com.sg

**Slovenija**

Phone +386 (0)1-47 69 990  
E-Mail office@sick.si

**South Africa**

Phone +27 11 472 3733  
E-Mail info@sickautomation.co.za

**South Korea**

Phone +82 2 786 6321/4  
E-Mail info@sickkorea.net

**Suomi**

Phone +358-9-25 15 800  
E-Mail sick@sick.fi

**Sverige**

Phone +46 10 110 10 00  
E-Mail info@sick.se

**Taiwan**

Phone +886-2-2375-6288  
E-Mail sales@sick.com.tw

**Türkiye**

Phone +90 (216) 528 50 00  
E-Mail info@sick.com.tr

**United Arab Emirates**

Phone +971 (0) 4 8865 878  
E-Mail info@sick.ae

**USA/México**

Phone +1(952) 941-6780  
1 800-325-7425 – tollfree  
E-Mail info@sickusa.com

More representatives and agencies  
at [www.sick.com](http://www.sick.com)