



Bar code scanners  
CLV41x / CLV414 / Short Range

CLV414-3010



**Model Name** > [CLV414-3010](#)  
**Part No.** > [1016831](#)



**At a glance**

- Available as line and raster scanners
- Easy to configure
- Reliable operation
- Profile programming included
- Beeper provides audible confirmation of good read
- Auto setup
- Adjustable scanning frequency up to 800 scans per second

**Your benefits**

- Readily adaptable to your application
- Small size and simple setup enables fast installation, even in compact machines
- Short commissioning time
- Excellent price/performance ratio

**The product is currently being phased out and can be ordered until September 30, 2014. Please contact your SICK sales representative for more information about a replacement product.**



**Features**

Version:	Short Range
Connection type:	Standard
Reading field:	Side (105 °)
Scanner design:	Raster scanner
Focus:	Fixed focus
Light source:	Visible red light (laser, 670 nm)
MTBF:	20,000 h
Laser class:	2 (DIN EN 60825-1)
Field of view:	≤ 50 °
Code resolution:	≥0.2 mm
Reading distance (at code resolution):	42 mm ... 97 mm (0.2 mm)
Raster height, number of lines, at distance:	15 mm, 8, 185 mm
Scanning frequency:	200 Hz ... 800 Hz

## Performance

---

Bar code types:	Interleaved 2 of 5, All current code types, Codabar, Code 128, Code 39, Code 93, GS1-128/EAN 128, Pharmacode, UPC/GTIN/EAN
Print ratio:	2:1 ... 3:1
No. of codes per scan:	1 ... 3
No. of codes per reading interval:	1 ... 10
No. of characters per reading interval:	100
No. of multiple readings:	1 ... 99

## Interfaces

---

Serial (RS-232, RS-422/485):	✓
Remark (Serial (RS-232, RS-422/485)):	AUX (only RS-232)
Function (Serial (RS-232, RS-422/485)):	Host, AUX
Data transmission rate (Serial (RS-232, RS-422/485)):	300 Baud ... 57,600 Baud, AUX: 9,600 Baud
Ethernet:	-
CAN bus:	-
PROFIBUS DP:	-
EtherCAT:	-
DeviceNet:	-
Switching inputs:	2 ("Sensor 1", "Sensor 2")
Switching outputs:	3 ("Result 1", "Result 2", "Result 3")
Reading pulse:	Non-powered, Reflector polling, "Sensor 1" switching input, Serial interface
Optical indicators:	4 LEDs (function indicator)
Acoustic indicators:	Beeper/buzzer (can be switched off, can be allocated as a result status indication function)

## Mechanics/electronics

---

Electrical connection:	1 15-pin D-Sub HD plug (0.9 m)
Operating voltage:	5 V DC ... 30 V DC <sup>1)</sup>
Power consumption:	3 W
Housing:	Die-cast zinc, does not contain paint wetting impairment substances
Housing color:	Light blue (RAL 5012)
Enclosure rating:	IP 65 (DIN 40 050)
Protection class:	III (IEC 1010-1)
Weight:	320 g, with connecting cable
Dimensions:	72 mm x 62.7 mm x 35.2 mm

<sup>1)</sup> UL certified for use with a Class 2 mains supply unit (checked to UL 1310)

## Ambient data

---

Electromagnetic compatibility (EMC):	(EN 61000-6-3) (EN 61000-6-2)
Vibration resistance:	(IEC 68-2-6 Test FC)
Shock resistance:	(IEC 68-2-27 Test EA)
Ambient operating temperature:	0 °C ... 40 °C
Storage temperature:	-20 °C ... 70 °C
Permissible relative humidity:	± 90 %, non-condensing
Ambient light safety:	2,000 lx, on bar code
Bar code print contrast (PCS):	≥ 60 %

## General notes

Life cycle phase:

Available until September 30th, 2014

## Dimensional drawing

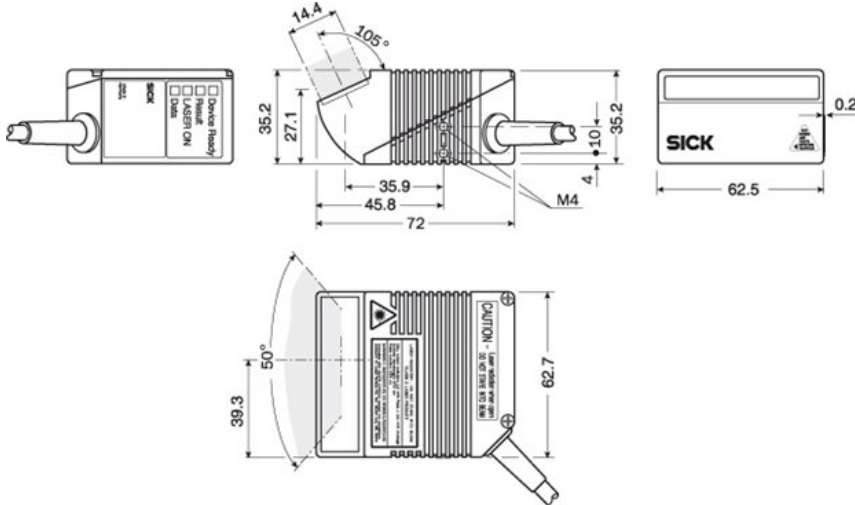

## Reading field diagram

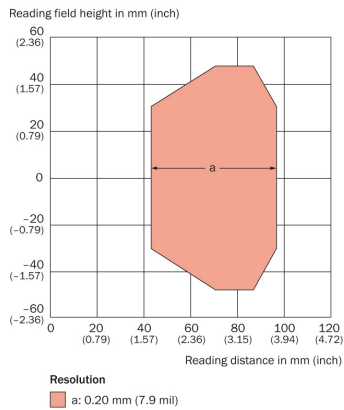

**Australia**

Phone +61 3 9457 0600  
1800 334 802 – tollfree  
E-Mail sales@sick.com.au

**Belgium/Luxembourg**

Phone +32 (0)2 466 55 66  
E-Mail info@sick.be

**Brasil**

Phone +55 11 3215-4900  
E-Mail sac@sick.com.br

**Canada**

Phone +1 905 771 14 44  
E-Mail information@sick.com

**Ceská Republika**

Phone +420 2 57 91 18 50  
E-Mail sick@sick.cz

**China**

Phone +86 4000 121 000  
E-Mail info.china@sick.net.cn  
Phone +852-2153 6300  
E-Mail ghk@sick.com.hk

**Danmark**

Phone +45 45 82 64 00  
E-Mail sick@sick.dk

**Deutschland**

Phone +49 211 5301-301  
E-Mail kundenservice@sick.de

**España**

Phone +34 93 480 31 00  
E-Mail info@sick.es

**France**

Phone +33 1 64 62 35 00  
E-Mail info@sick.fr

**Great Britain**

Phone +44 (0)1727 831121  
E-Mail info@sick.co.uk

**India**

Phone +91-22-4033 8333  
E-Mail info@sick-india.com

**Israel**

Phone +972-4-6801000  
E-Mail info@sick-sensors.com

**Italia**

Phone +39 02 27 43 41  
E-Mail info@sick.it

**Japan**

Phone +81 (0)3 3358 1341  
E-Mail support@sick.jp

**Magyarország**

Phone +36 1 371 2680  
E-Mail office@sick.hu

**Nederlands**

Phone +31 (0)30 229 25 44  
E-Mail info@sick.nl

**Norge**

Phone +47 67 81 50 00  
E-Mail austefjord@sick.no

**Österreich**

Phone +43 (0)22 36 62 28 8-0  
E-Mail office@sick.at

**Polska**

Phone +48 22 837 40 50  
E-Mail info@sick.pl

**România**

Phone +40 356 171 120  
E-Mail office@sick.ro

**Russia**

Phone +7-495-775-05-30  
E-Mail info@sick.ru

**Schweiz**

Phone +41 41 619 29 39  
E-Mail contact@sick.ch

**Singapore**

Phone +65 6744 3732  
E-Mail admin@sicksgp.com.sg

**Slovenija**

Phone +386 (0)1-47 69 990  
E-Mail office@sick.si

**South Africa**

Phone +27 11 472 3733  
E-Mail info@sickautomation.co.za

**South Korea**

Phone +82 2 786 6321/4  
E-Mail info@sickkorea.net

**Suomi**

Phone +358-9-25 15 800  
E-Mail sick@sick.fi

**Sverige**

Phone +46 10 110 10 00  
E-Mail info@sick.se

**Taiwan**

Phone +886-2-2375-6288  
E-Mail sales@sick.com.tw

**Türkiye**

Phone +90 (216) 528 50 00  
E-Mail info@sick.com.tr

**United Arab Emirates**

Phone +971 (0) 4 8865 878  
E-Mail info@sick.ae

**USA/México**

Phone +1(952) 941-6780  
1 800-325-7425 – tollfree  
E-Mail info@sickusa.com

More representatives and agencies  
at [www.sick.com](http://www.sick.com)